

40W High-Integration, High-Efficiency PMIC for Wireless Power Transmitter

FEATURES

- VIN Input Voltage Range: 4.2V-30V
- PVIN Input Voltage Range: 1V~26V
- Up to 40W Power Transfer
- Integrated Full-Bridge Power Stage with 13-mΩ R_{ds(on)} of Power MOSFETs
- Integrated High Efficiency 5V-1A Step-down DC/DC Converter
- Build-in 3.3V-200mA LDO
- Integrated Lossless Input Current Sensor with ±2% accuracy for FOD and current Demodulation
- Integrated voltage and current demodulation
- Integrated Q factor detection
- 3.3V and 5V PWM Signal Logic Compatible
- Input Under-Voltage Lockout
- Over Current Protection
- Over Temperature Protection
- Available in QFN-22L 4mm*4mm Package
- Available in AEC-Q100 Grade-1

APPLICATIONS

- WPC MPP/EPP Chargers of 10W to 40W Systems for Mobiles and tablets
- General Wireless Power Transmitters for Consumer, Industrial and Medical Equipment
- Proprietary Wireless Chargers and Transmitters

DESCRIPTION

The SCT63340Q is a highly integrated Power Management IC allows achieving high performance, high efficiency and cost effectiveness of wireless power transmitter system compliant with WPC specification to support up to 40W power transfer, working with a wireless application specific controller ASIC or a general MCU based transmitter controller.

This device integrates a 4-MOSFETs full bridge, gate drivers, a 5V step-down DC/DC converter, a 3.3V LDO, communication demodulator, Q-factor detection and input current sensor for both system efficiency and easy-to-use.

The proprietary gate driving scheme optimizes the performance of EMI reduction to save the system cost and design. The proprietary lossless current sensing circuitry with ±2% accuracy monitors input current of full bridge to support Foreign Object Detection FOD and current demodulation. The build-in 5V step-down DC/DC converter and 3.3V low dropout regulator LDO can provide power supplies to transmitter controller and external circuitries.

The SCT63340Q features input under-voltage lock-out UVLO protection, over current protection, short circuit protection, and over temperature protection for robust design.

The SCT63340Q is available in a compact QFN 4mm*4mm package.

TYPICAL APPLICATION

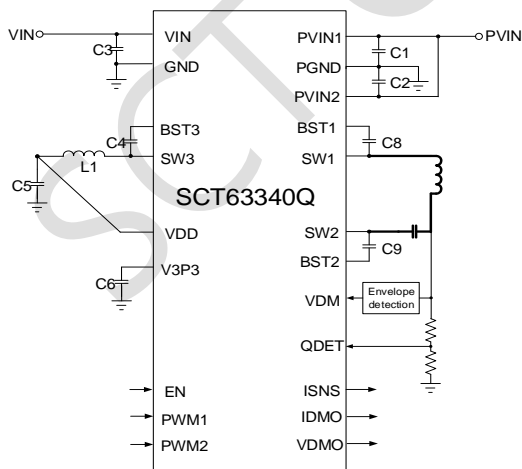

Power Transfer Efficiency with 15W RX @ V_{out}=12V

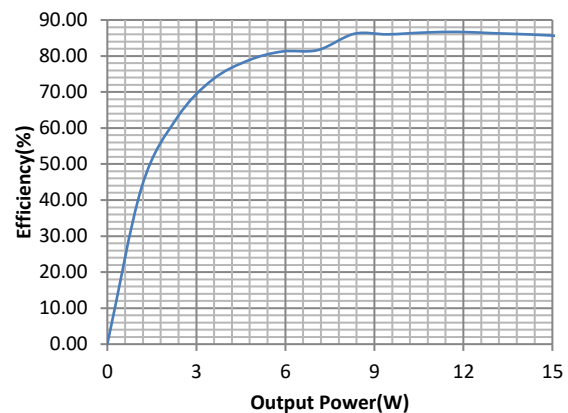

SCT63340Q

REVISION HISTORY

NOTE: Page numbers for previous revisions may differ from page numbers in the current version.

Revision 0.8: Customer sample

Revision 0.81: Update DEVICE ORDER INFORMATION

DEVICE ORDER INFORMATION

ORDERABLE DEVICE	PACKAGING TYPE	STANDARD PACK QTY	PACKAGE MARKING	PINS	PACKAGE DESCRIPTION
SCT63340QFFAR	Tape & Reel	5000	3340Q	22	QFN-22L

ABSOLUTE MAXIMUM RATINGS

Over operating free-air temperature unless otherwise noted⁽¹⁾

DESCRIPTION	MIN	MAX	UNIT
VIN	-0.3	32	V
PVIN1, PVIN2	-0.3	28	V
SW1,SW2	-1	28	V
SW3	-1	32	V
BST1,BST2	-0.3	34	V
BST3	-1	38	V
BST1-SW1,BST2-SW2,BST3-SW3	-0.3	6	V
VDD, V3P3, VDM, EN, PWM1, PWM2, ISNS, IDMO, VDMO, QDET	-0.3	6	V
Operating junction temperature T _J ⁽²⁾	-40	150	°C
Storage temperature T _{STG}	-65	150	°C

PIN CONFIGURATION

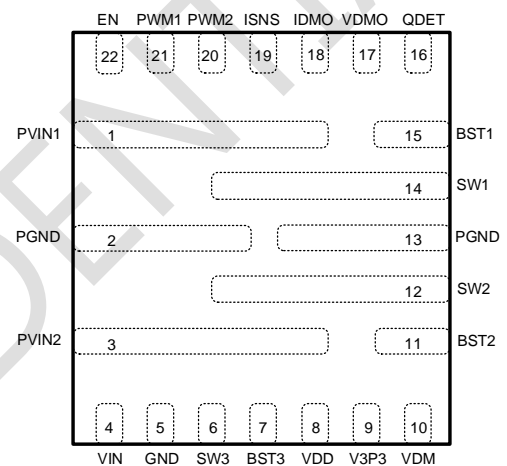

Figure 1. Top view 22-Lead QFN 4mm*4mm

- (1) Stresses beyond those listed under Absolute Maximum Rating may cause device permanent damage. The device is not guaranteed to function outside of its Recommended Operation Conditions.
- (2) The IC includes over temperature protection to protect the device during overload conditions. Junction temperature will exceed 150°C when over temperature protection is active. Continuous operation above the specified maximum operating junction temperature will reduce lifetime.

PIN FUNCTIONS

NAME	NO.	PIN FUNCTION
PVIN1	1	Input supply voltage of half-bridge FETs Q1 and Q2. Connected to the drain of high side FET Q1. a local bypass capacitor from PVIN1 pin to PGND pin should be added. Path from PVIN1 pin to high frequency bypass capacitor and PGND must be as short as possible.
PGND	2, 13	PGND is the common power ground of the full bridge, connected to the source terminal of low side FETs Q2 and Q4 internally.
PVIN2	3	Input supply voltage of half-bridge FETs Q3 and Q4. Connected to the drain of high side FET Q3. Local bypass capacitor from PVIN1 pin to PGND pin should be added. Path from PVIN1 pin to high frequency bypass capacitor and PGND must be as short as possible.
VIN	4	Input supply voltage of the Buck converter. Add a local bypass capacitor from VIN pin to GND pin. Path from VIN pin to high frequency bypass capacitor and GND must be as short as possible.
GND	5	Power ground of the Buck converter.

SW3	6	Switching output of the Buck converter. Connect SW3 to an external power inductor.
BST3	7	Power supply bias for the high-side power MOSFET gate driver of Buck converter. Connect a 0.1uF capacitor from BST3 pin to SW3 pin.
VDD	8	Output voltage of the Buck converter. Connect 22uF capacitor from this pin to GND pin. VDD is also the input power supply for gate driver of power stage and the 3.3V LDO.
V3P3	9	3.3V LDO output. Connect 1uF capacitor to ground.
VDM	10	High-pass filter input. Voltage demodulation pin data packets based on coil voltage.
BST2	11	Power supply bias for the high-side power MOSFET gate driver of Q3 as shown in the block diagram. Connect a 0.1uF capacitor from BST2 pin to SW2 pin.
SW2	12	Switching node of the half-bridge FETs Q3 and Q4.
SW1	14	Switching node of the half-bridge FETs Q1 and Q2.
BST1	15	Power supply bias for the high-side power MOSFET gate driver of Q1 as shown in the block diagram. Connect a 0.1uF capacitor from BST1 pin to SW1 pin.
QDET	16	Q-factor detection input.
VDMO	17	Voltage demodulation output
IDMO	18	Current demodulation output
ISNS	19	Current detection output. The voltage of the pin is proportional to the input current.
PWM2	20	PWM logic input to the FET Q3 and Q4 as shown in the Block Diagram. Logic HIGH turns off the low-side FET Q4, and turns on the high-side FET Q3. Logic LOW turns off the high-side FET Q3 and turns on the low-side FET Q4. When PWM input is in the tri-state mode, both Q3 and Q4 are turned off.
PWM1	21	PWM logic input to the FET Q1 and Q2 as shown in the Block Diagram. Logic HIGH turns off the low-side FET Q2, and turns on the high-side FET Q1. Logic LOW turns off the high-side FET Q1 and turns on the low-side FET Q2. When PWM input is in the tri-state mode, both Q1 and Q2 are turned off.
EN	22	Enable pin. Pull the pin high or keep it floating to enable the IC. When the device is enabled, Buck converter will start to work if VIN higher than UVLO threshold. After VDD is established, power stage responds to PWM input logic then.

RECOMMENDED OPERATING CONDITIONS

Over operating free-air temperature range unless otherwise noted

PARAMETER	DEFINITION	MIN	MAX	UNIT
V _{IN}	Input voltage range	4.2	30	V
P _{VIN}	Input voltage range	1	26	V
T _J	Operating junction temperature	-40	125	°C

ESD RATINGS

PARAMETER	DEFINITION	MIN	MAX	UNIT
V _{ESD}	Human Body Model(HBM), per ANSI-JEDEC-JS-001-2014 specification, all pins ⁽¹⁾	-2	+2	kV
	Charged Device Model(CDM), per ANSI-JEDEC-JS-002-2014specification, all pins ⁽²⁾	-1	+1	kV

(1) JEDEC document JEP155 states that 500V HBM allows safe manufacturing with a standard ESD control process.

(2) JEDEC document JEP157 states that 250V CDM allows safe manufacturing with a standard ESD control process.

SCT63340Q

THERMAL INFORMATION

PARAMETER	THERMAL METRIC	QFN-22L	UNIT
R _{θJA}	Junction to ambient thermal resistance ⁽¹⁾	40	°C/W
R _{θJC}	Junction to case thermal resistance ⁽¹⁾	24	

(1) SCT provides R_{θJA} and R_{θJC} numbers only as reference to estimate junction temperatures of the devices. R_{θJA} and R_{θJC} are not a characteristic of package itself, but of many other system level characteristics such as the design and layout of the printed circuit board (PCB) on which the SCT63340Q is mounted, thermal pad size, and external environmental factors. The PCB board is a heat sink that is soldered to the leads of the SCT63340Q. Changing the design or configuration of the PCB board changes the efficiency of the heat sink and therefore the actual R_{θJA} and R_{θJC}.

ELECTRICAL CHARACTERISTICS

$V_{IN}=V_{PVIN1}=V_{PVIN2}=12V$, $V_{DD}=5V$, typical value is tested under 25°C.

SYMBOL	PARAMETER	TEST CONDITION	MIN	TYP	MAX	UNIT
Input supplies and UVLO						
V_{IN}	Operating input voltage		4.2		30	V
P_{VIN}	Operating input voltage		1		26	V
V_{IN_UVLO}	V_{IN} UVLO Threshold Hysteresis	V_{IN} rising		3.56 330	4	V mV
V_{DD_UVLO}	V_{DD} UVLO Threshold Hysteresis	V_{DD} rising		3.87 420	4.19	V mV
I_{SHDN}	Shutdown current from VIN pin	EN=0V, VIN=12V		1.5	3	μA
I_{SHDN_PVIN}	Shutdown current from PVIN1,PVIN2	EN=0V, PVIN=12V		1	3	uA
I_{SHDN_VDD}	Shutdown current from VDD	EN=0V, VDD=5V		15	26	uA
I_{VINQ}	Quiescent current from VIN pin	EN floating, VDD=5.5V, no switching, no loading on Buck and LDO		210		uA
I_{PVINQ}	Quiescent current from PVIN1, PVIN2	EN floating, VDD=5.5V, no switching, no loading on Buck and LDO		50		uA
I_Q	Quiescent current from VDD pin	EN floating, VDD=5.5V, no switching, no loading on Buck and LDO		550		uA

ENABLE INPUTS and PWM logic

V_{EN_H}	Enable high threshold			1.19		V
V_{EN_L}	Enable low threshold			1.1		V
V_{EN_HYS}	Enable threshold hysteresis			90		mV
V_{IH}	PWM1, PWM2 Logic level high	V3P3=3.3V, VDD=5V	2.65			V
V_{IL}	PWM1, PWM2 Logic level low	V3P3=3.3V, VDD=5V			0.55	V
V_{TS}	PWM1, PWM2 Tri-state voltage		1.2		2	V

Power Stage

R_{DSON_Q1}	High-side MOSFETQ1 on-resistance	$V_{BST1}-V_{SW1}=5V$		13		mΩ
R_{DSON_Q2}	Low-side MOSFETQ2 on-resistance	VDD=5V		13		mΩ
R_{DSON_Q3}	High-side MOSFETQ3 on-resistance	$V_{BST2}-V_{SW2}=5V$		13		mΩ
R_{DSON_Q4}	Low-side MOSFETQ4 on-resistance	VDD=5V		13		mΩ
I_{LIM}	High-side current limit threshold			12.5		A

Buck converter

F_{SW}	Switching frequency		405	450	495	KHz
V_{DD}	Output voltage		4.925	5	5.075	V
I_{LIM_HS}	High-side power MOSFET peak current limit threshold			1.8		A
T_{HIC_W}	Over current protection hiccup wait time			1.2		ms
T_{HIC_R}	Over current protection hiccup restart time			18		ms
R_{DSON_H}	High side FET on-resistance			500		mΩ

SCT63340Q

SYMBOL	PARAMETER	TEST CONDITION	MIN	TYP	MAX	UNIT
R _{DSON_L}	Low side FET on-resistance			250		mΩ
T _{SS}	Internal soft-start time			1.4		ms

3.3V LDO

V _{3P3}	Output voltage	C _{out} =1uF, VDD=5V	3.267	3.3	3.333	V
I _{3P3}	Output current Capability			220		mA
I _{SC1}	Short current			40		mA

Current Sense

V _{ISNS0}	Voltage with no input current	I _{PGND} =0A, PWM1=PWM2=0V	0.585	0.6	0.615	V
R _{ISNS}	Input current to output voltage gain	V _{ISNS} =V _{ISNS0} +I _{PGND} *R _{ISNS}	0.98	1	1.02	V/A
V _{ISNS1}	Voltage with 0.6A input current	I _{PVIN} =0.6A	1.176	1.2	1.224	V
V _{ISNS2}	Voltage with 1A input current	I _{PVIN} =1A	1.568	1.6	1.632	V

Protection

T _{SD}	Thermal shutdown threshold	T _J rising		155		°C
	Hysteresis			35		°C

TYPICAL CHARACTERISTICS

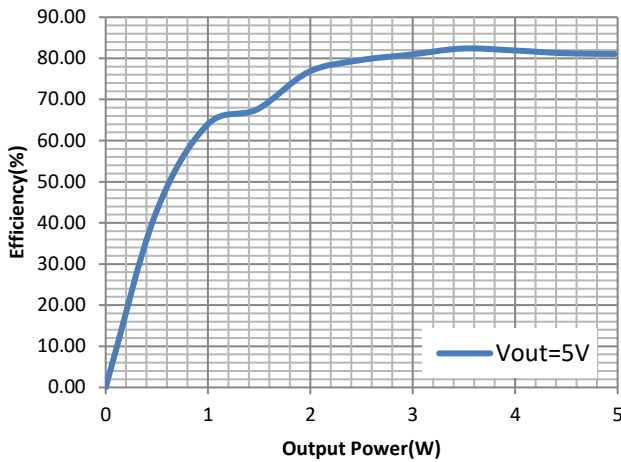

Figure 2. Transfer Efficiency with 5W RX @ Vout=5V

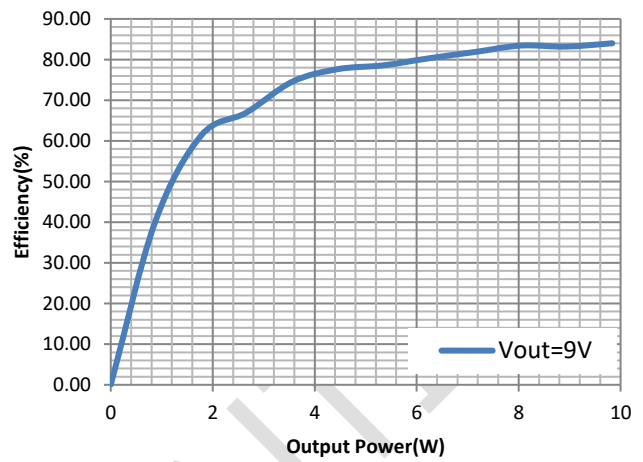

Figure 3. Transfer Efficiency with 10W RX @ Vout=9V

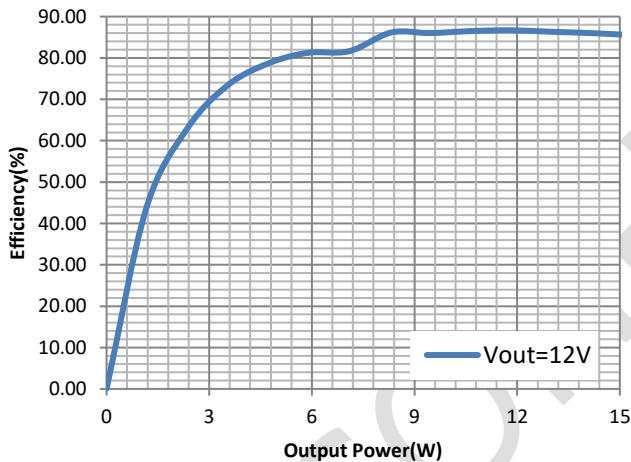

Figure 4. Transfer Efficiency with 15W RX @ Vout=12V

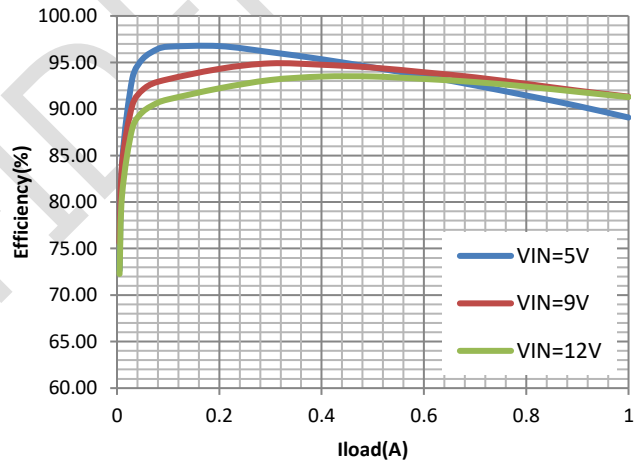

Figure 5. Buck Converter Efficiency

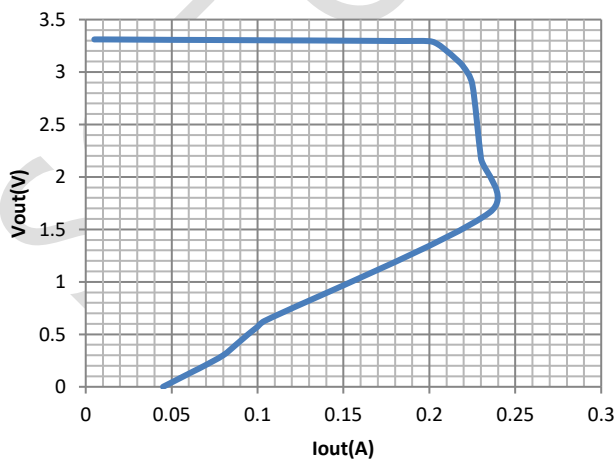

Figure 6. 3.3V LDO Iout vs Vout

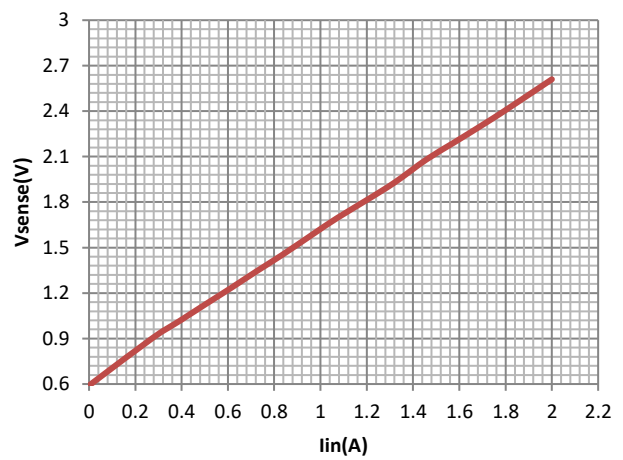

Figure 7. Current Sense Output Voltage vs Iin

FUNCTIONAL BLOCK DIAGRAM

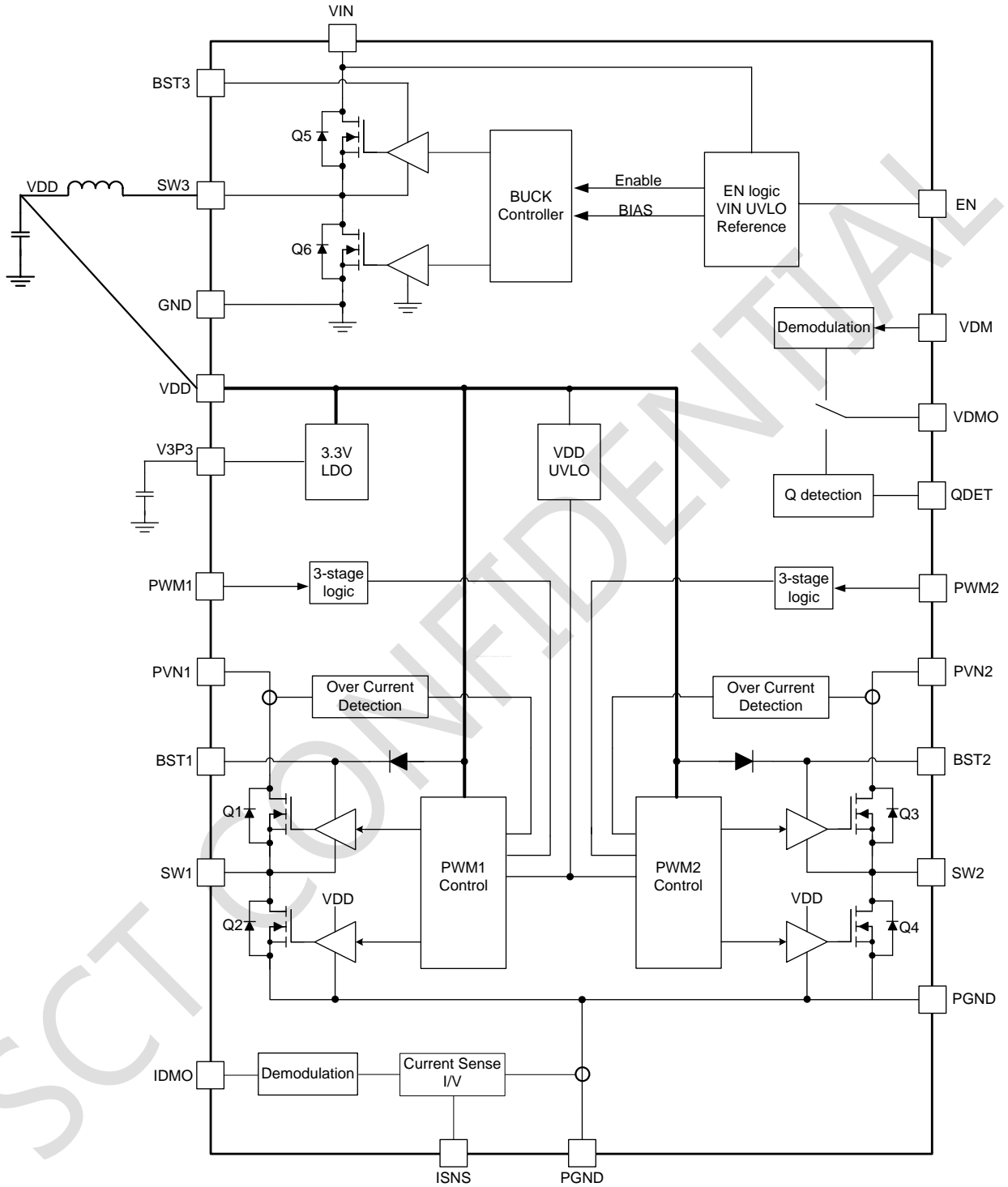

Figure 8. Functional Block Diagram

OPERATION

Overview

The SCT63340Q is a highly integrated power management unit optimized for wireless power transmitter applications. This device integrates the power functions required to a wireless power transmitter including 5V buck converter as power supply for external transmitter controller and internal 5V power supply to increase system efficiency, full bridge power stage to convert DC input power to AC output for driving LC resonant circuit, lossless current sensing with $\pm 2\%$ accuracy, 3.3V output LDO for powering MCU.

The SCT63340Q has four power input pins. VIN is connected to the power FETs of buck converter. PVIN1 and PVIN2 are connected to the power FETs of the full bridge and conducts high currents for transferring power. VDD is the output feedback pin of the 5V output buck converter meanwhile as the power supply for internal two LDOs and full bridge MOSFET's gate driver.

VIN and PVIN1, PVIN2 can be powered separately for more flexibility of system power design. The operating voltage range for VIN is from 4.2V to 30V. An Under-voltage Lockout(UVLO) circuit monitors the voltage of VIN pin and disable the IC operation when VIN voltage falls below the UVLO threshold of 3.2V typically. The maximum operating voltage for PVIN is up to 26V while the minimum voltage accepted can be down to 1V. Another UVLO circuit also supervise the VDD voltage which is the power supply for gated drivers of full bridge MOSFETs. Full bridge power stage enables working when VDD UVLO release.

Two independent PWM signals control two separate half bridge MOSFETs with internal adaptive non-overlap circuitry to prevent the shoot-through of MOSFETs in each bridge. PWM logics are compatible for both 3.3V and 5V IOs so the SCT63340Q can accept PWM signal from the controller with using either 3.3V or 5V power supply.

The buck converter and full bridge of power MOSFETs includes proprietary designed gate driver scheme to resist switching node ringing without sacrificing MOSFET turn-on and turn-off speed, which further erases high frequency radiation EMI noise caused by the MOSFETs hard switching. This allows the user to reduce the system cost and design effort for EMI reduction.

The SCT63340Q full protection features include VIN and VDD under-voltage lockout, over current protection with cycle-by-cycle current limit and hiccup mode, output hard short protection for buck converter and 4-MOSFETs full bridge, current limit and current fold back at hard short for the LDO and whole chip thermal shutdown protection.

Enable and Start up Sequence

When the VIN pin voltage rises above 3.6V and the EN pin voltage exceeds the threshold of 1.19V, the buck converter and two LDOs enable. The device disables when the VIN pin voltage falls below 3.2V or when the EN pin voltage is below 1.1V. VDD ramps up with buck converter working, and also the V3V output does. Once VDD and V3V rise up to 3.87V and 3V respectively, PWM signal can control 4-MOSFETs power stage for switching. PWM input cannot control full bridge of MOSFETs if VDD drop to 3.45V or V3V drop to 2.7V.

An internal 1.5uA pull up current source to EN pin allows the device enable when EN pin floats to simply the system design. If an application requires a higher system input under voltage lockout threshold, two external resistors divider (R1 and R2) in Figure 9 can be used to achieve an expected system UVLO. The UVLO rising and falling threshold can be calculated by Equation 1 and Equation 2 respectively.

$$V_{\text{rise}} = 1.19 * \left(1 + \frac{R1}{R2}\right) - 1.5\mu\text{A} * R1 \quad (1)$$

$$V_{\text{fall}} = 1.1 * \left(1 + \frac{R1}{R2}\right) - 5.5\mu\text{A} * R1 \quad (2)$$

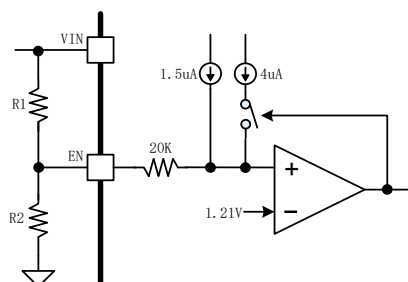

Figure9. System UVLO by enable divider

5V Output Buck Converter

The SCT63340Q fully integrates synchronous buck converter with up to 30V input voltage and 5V fixed output voltage, which offers up to 1A output current capability. The device employs 450KHz fixed frequency peak current mode control with the internal loop compensation network and built-in 1.4ms soft-start which makes this buck converter easily to be used by minimizing the off-chip component count. Pulse Skipping Modulation(PSM) is adopted to increase the light load efficiency.

The buck converter's output, a fixed 5V voltage, supports the power requirement on system such as transmitter controller or mechanical fan meanwhile it is also the power supply of the SCT63340Q's 3.3V LDO and gate drivers of 4-MOSFETs full bridge. Connect 22uF capacitor from VDD to GND and add a 0.1uF local bypass ceramic capacitor placed close to the IC.

The converter has proprietary designed gate driver scheme to resist switching node ringing without sacrificing MOSFET turn-on and turn-off time, which further erases high frequency radiation EMI noise caused by the MOSFETs hard switching.

An external 100nF ceramic bootstrap capacitor between BST3 and SW3 pin powers floating high-side power MOSFET gate driver. The bootstrap capacitor voltage is charged from an integrated voltage regulator when high-side power MOSFET is off and low-side power MOSFET is on.

Buck converter implements over current protection with cycle-by-cycle limiting high-side MOSFET peak current and also low-side MOSFET valley current to avoid inductor current running away during unexpected overload and hiccup protection in output hard short condition. When overload or hard short happens, the converter cannot provide output current to satisfy loading requirement even though the inductor current has already been clamped at over current limitation. Thus, output voltage drops below regulated voltage continuously. When output voltage under regulation lasts for 1.2ms, the converter stops switching; After remaining OFF for 18ms, the device will attempt to restart from soft-start.

The hiccup protection mode above greatly reduces the average short circuit current to alleviate thermal issues and protect the regulator.

Full Bridge Power Stage and PWM Control

The SCT63340Q integrates full bridge power stage with only 13mohm on-resistance for each power MOSFET optimized for wireless power transmitter driving the LC resonant circuit. This full bridge operates in a wide switching frequency range from 20KHz to 400KHz for different applications which is completely compatible with WPC's frequency requirement from 100KHz to 205KHz.

PWM1 input controls the half bridge comprised of high side MOSFET Q1 and low side MOSFET Q2, and PWM2 input controls the half bridge comprised of high side MOSFET Q3 and low side MOSFET Q4 as shown in block diagram. The PWM1 and PWM2 independently control the SW1 and SW2 duty cycle and frequency. Logic HIGH will turn off low side FET and turn on high side FET, and logic LOW will turn off high side FET and turn on low side FET.

PWM1 and PWM2 also support tri-state input. When PWM input logic first enters tri-state either from logic HIGH or logic LOW, the states of its controlled FETs stay the same. If the PWM input stays in the tri-state for more than 60ns, its controlled FETs are all turned off, and the corresponding SW output becomes high impedance. The FETs stay off until the PWM logic reaches logic HIGH or logic LOW threshold.

An external 100nF ceramic bootstrap capacitor between BST1 and SW1 pin powers floating high-side power MOSFET Q1's gate driver, and the other 100nF bootstrap capacitor between BST2 and SW2 pin powers for the Q3's. When low side FET is on as SW is low, the bootstrap capacitor is charged through internal path by VDD power supply rail.

PWM cannot stay high level for more than 2ms since the voltage of bootstrap capacitor will be discharged by internal leakage current if high side FET keeps on.

Full Bridge Over Current Protection

The SCT63340Q integrates cycle-by-cycle current limit and hiccup mode for over-current protection. The current of the high side FET Q1 and Q3 is sensed and compared to the current limit threshold during each switching cycle. If the current exceeds the threshold, 12.5A typical, the high side FET turns off immediately in present cycle to avoid current increasing further even that PWM signal still stays in high level. The over current counter is incremented. If one high side FET occurs over current in 5 consecutive cycles, then all 4 internal FETs are turned off regardless of the PWM inputs. The full bridge enters hiccup mode and will attempt to restart after a time-out period of 24ms typically.

Current Sense

The SCT63340Q has a proprietary lossless average current sensing circuit that measures the average input current of full bridge with $\pm 2\%$ accuracy and reports a proportional voltage directly to the ISNS pin. This voltage information on ISNS pin can be sent to application specific controller ASIC or general MCU for Foreign Object Detection FOD and current demodulation.

When the full bridge of MOSFETs does not work, no current flows to PGND. The DC bias voltage on ISNS pin is 600mV. This DC bias helps set up a suitable voltage bias for the following analog to digital converter in MCU or amplifier for current demodulation. The average input current to voltage conversion gain on ISNS is 1V/A. The equation 3 represent the corresponding relation for the output voltage on ISNS pin and average current to PGND from full bridge.

$$V_{ISNS} = 600\text{mV} + I_{PGND} * 1\text{V/A} \quad (3)$$

3.3V LDO

The SCT63340Q has an integrated low-dropout voltage regulator which powered from VDD and supply regulated 3.3V voltage on V3V pin. The output current capability is 200mA. This LDO can be used to bias the supply voltage of MCU directly.

It is recommended to connect a decoupling ceramic capacitor of 1uF to 10uF to the V3V pin. Capacitor values outside of the range may cause instability of the internal linear regulator.

Q Factor Detection

The SCT63340Q integrated a low cost, reliable Q factor detection circuit to assure foreign objects detection before the selection phase. It generates a small pulse to detect any foreign object on the transmitter coil, it can detect metal on the transmitter coil easily.

After chip enable, apply a low voltage level pulse to EN pin can trigger the Q factor detection feature. The pulse width should be longer than 50us but less than 200us. SW1 will be preset to 2V for 4.7ms and then pull low to ground and this apply power to LC resonant loop and Vcoil will appear damping oscillation after SW1 short to ground. The SCT63340Q will generate a pulse on VDMO pin and MCU can capture this pulse to calculate the Q factor by the pulse width as the Equation 4 shows. PWM1 and PWM2 should be low in Q factor detection phase.

$$Q = \frac{\Delta T * \pi}{10 * \ln \frac{V_{TH_HIGH}}{V_{TH_LOW}}} \quad (4)$$

where

- ΔT is the pulse width on VDMOS pin
- V_{TH_HIGH} is high threshold 0.2V
- V_{TH_LOW} is low threshold 0.1V

Voltage and Current Demodulation

The SCT63340Q integrates two demodulation schemes, one based on coil voltage information calling voltage demodulation and the other based on input average current information calling current demodulation.

SCT63340Q

The voltage mode envelope detector is implemented using a discrete solution as depicted on Figure10. This simple implementation achieves the envelope detector function, low-pass filter as well as the DC filter function. The envelope detector applies the analog signal to VDM pin and the chip do the demodulation and output a digital signal to VDMO pin which MCU can capture the voltage demodulation results and then implement the packet decode.

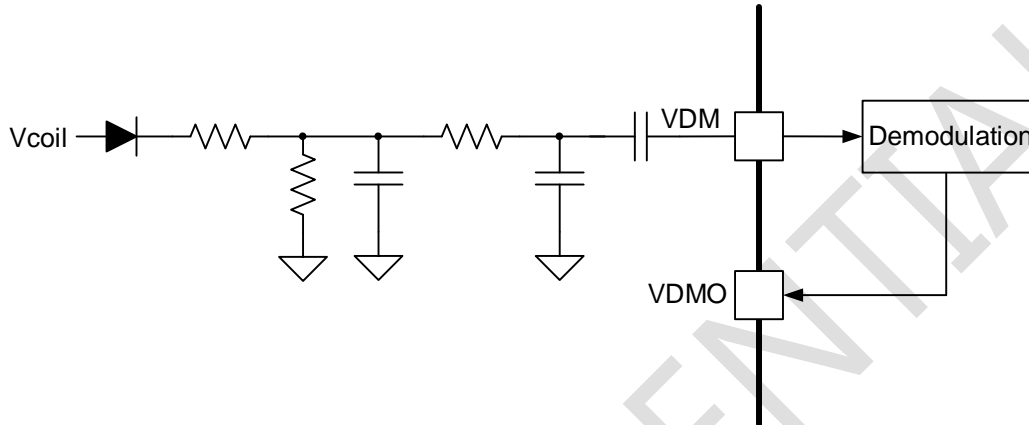

Figure 10. Envelope Detector

The current-mode detector takes the modulation information from the average input current which the chip can read from ISNS pin. The MCU can detect the demodulation results on VDMO and IDMO pins and then implement the packet decode.

Thermal Shutdown

The SCT63340Q protects the device from the damage during excessive heat and power dissipation condition. Once the junction temperature exceeds 155°C, the thermal sensing circuit stops Buck converter, two LDOs and full bridge of 4-MOSFETs' working. When the junction temperature falls below 120°C, then the device restarts.

APPLICATION INFORMATION

Typical Application

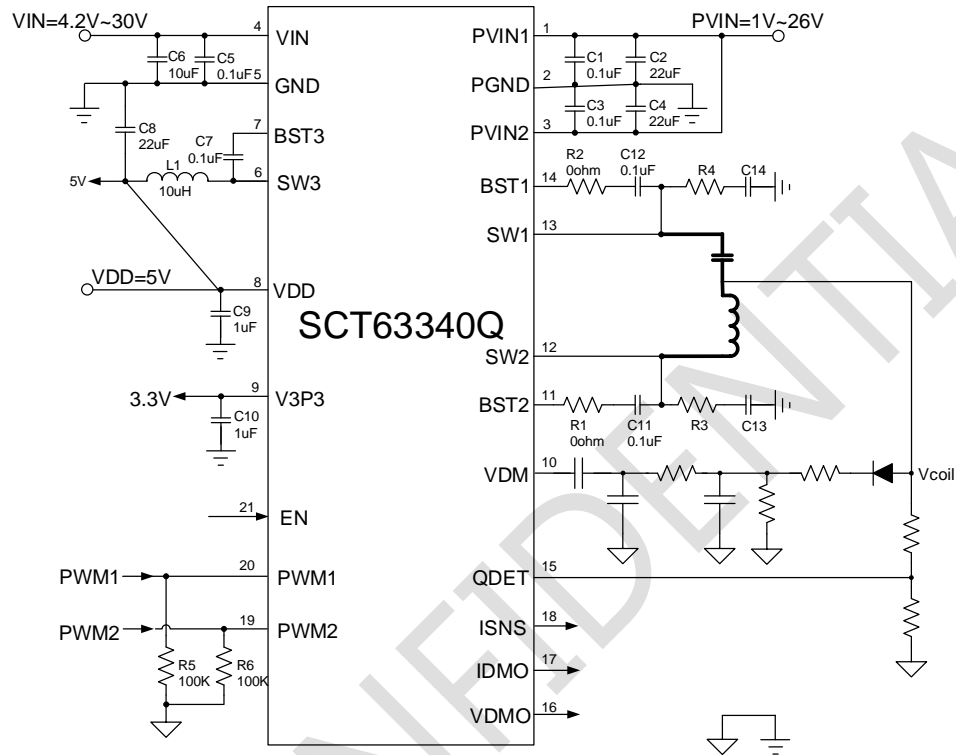

Figure 11. Separate Input to VIN and PVIN

Application Waveforms

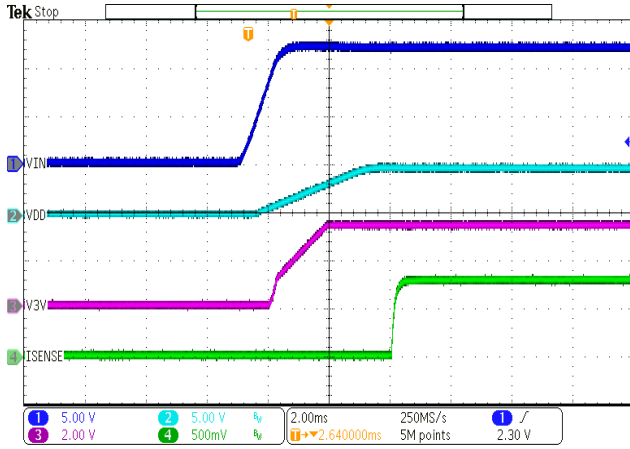

Figure 12. Power Up

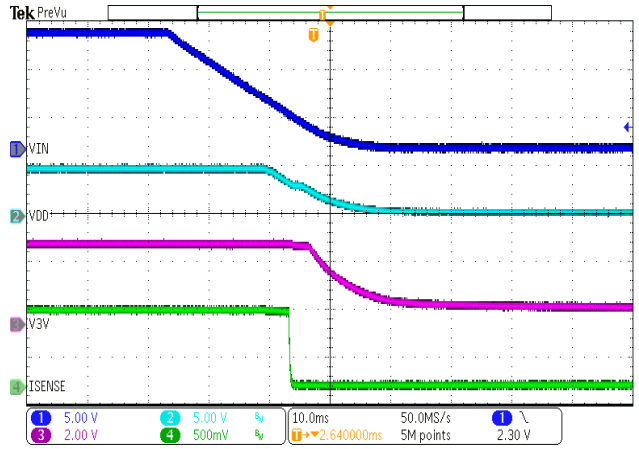

Figure 13. Power Down

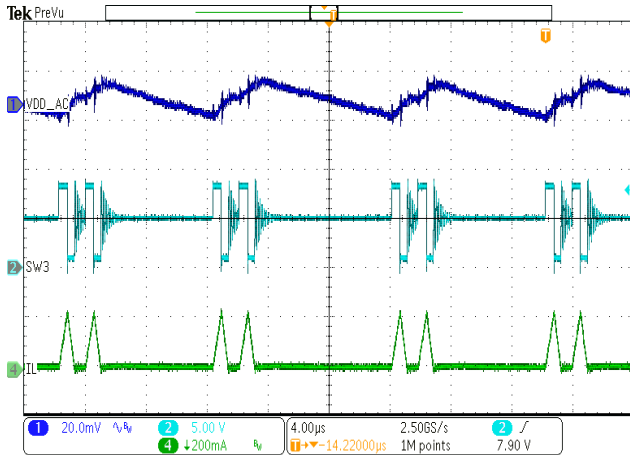

Figure 14. VDD Ripple and SW3 @ VIN=9V, IOU=20mA

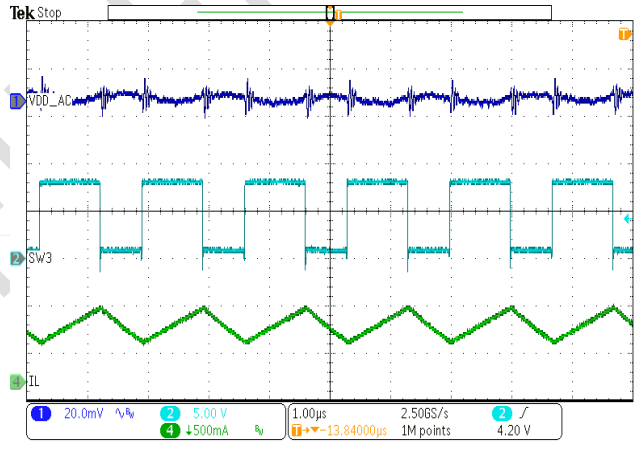

Figure 15. VDD Ripple and SW3 @ VIN=9V, IOU=600mA

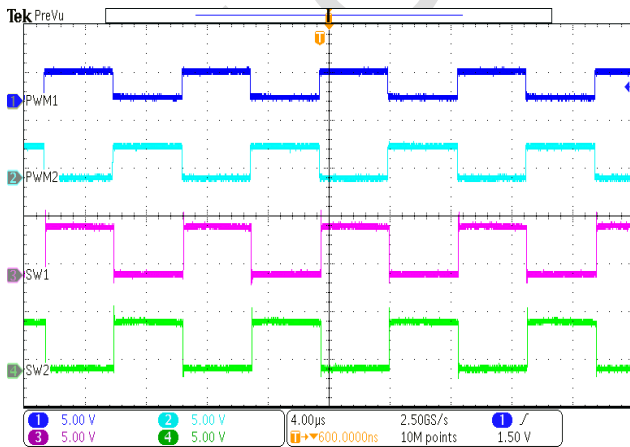

Figure 16. Full bridge @ Vin=5V, RX=5W

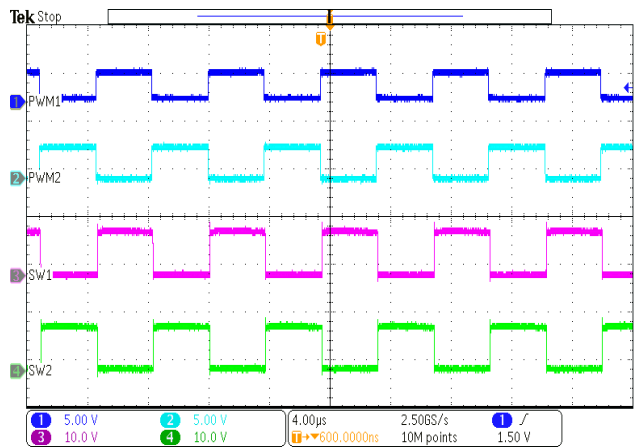

Figure 17. Full bridge @ Vin=9V, RX=10W

Layout Guideline

Proper PCB layout is a critical for SCT63340Q's stable and efficient operation. The traces conducting fast switching currents or voltages are easy to interact with stray inductance and parasitic capacitance to generate noise and degrade performance. For better results, follow these guidelines as below:

1. Bypass capacitors from PVIN to PGND should put next to PVIN and PGND pin as close as possible especially for the two small capacitors.
2. PGND connect to bottom layer by via between capacitors.
3. Bypass capacitors from VIN to GND should put next to VIN and GND pin as close as possible especially for the small capacitor.
4. Buck converter output capacitor's ground should connect to GND directly to minimize the power loop.
5. VDD pin can connect to the DC/DC's output capacitor from bottom layer, connect to the point behind the capacitor while not connect to inductor.
6. Bypass capacitor for VDD place next to VDD pin.
7. Bypass capacitor for V3P3 place next to V3P3 pin.

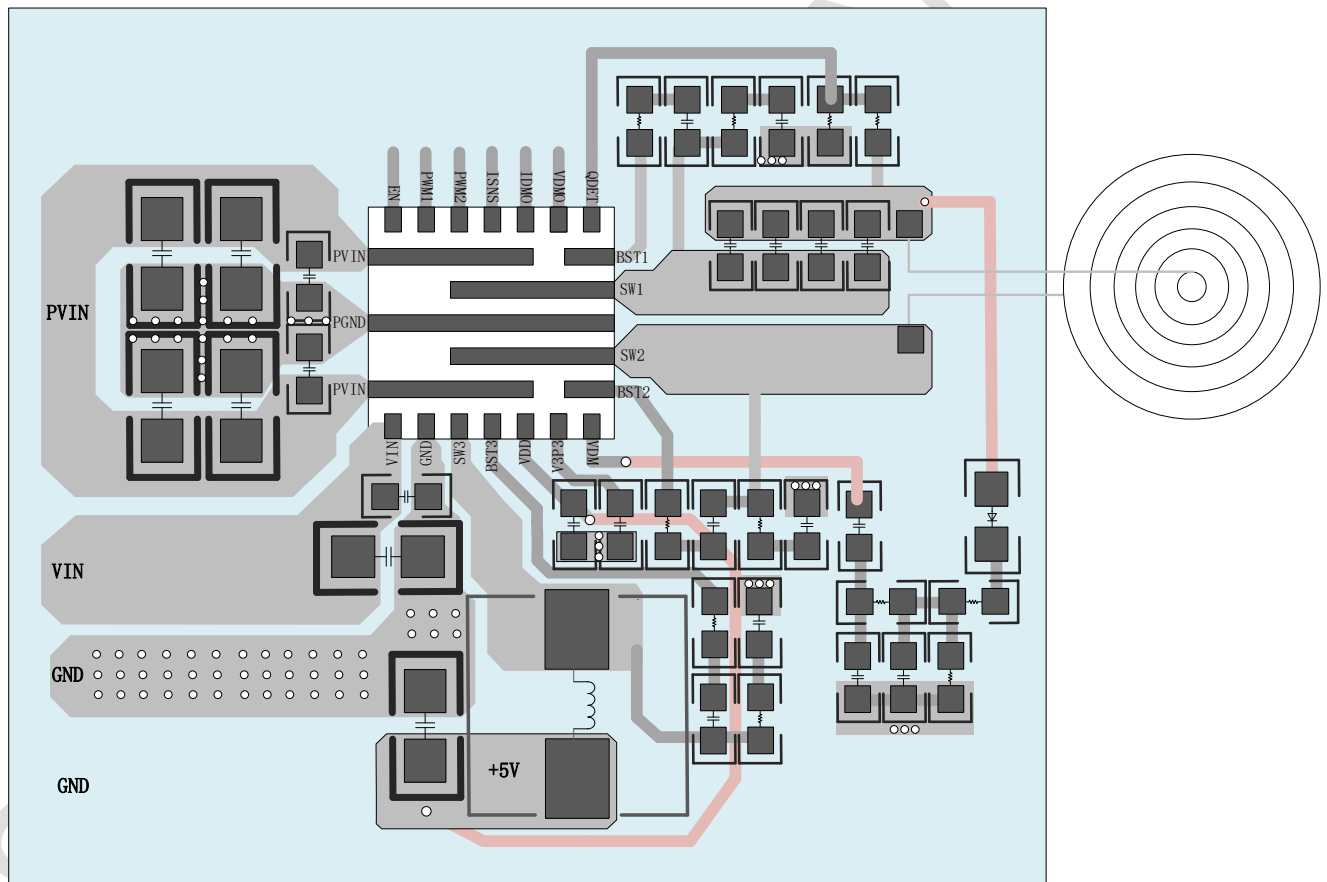
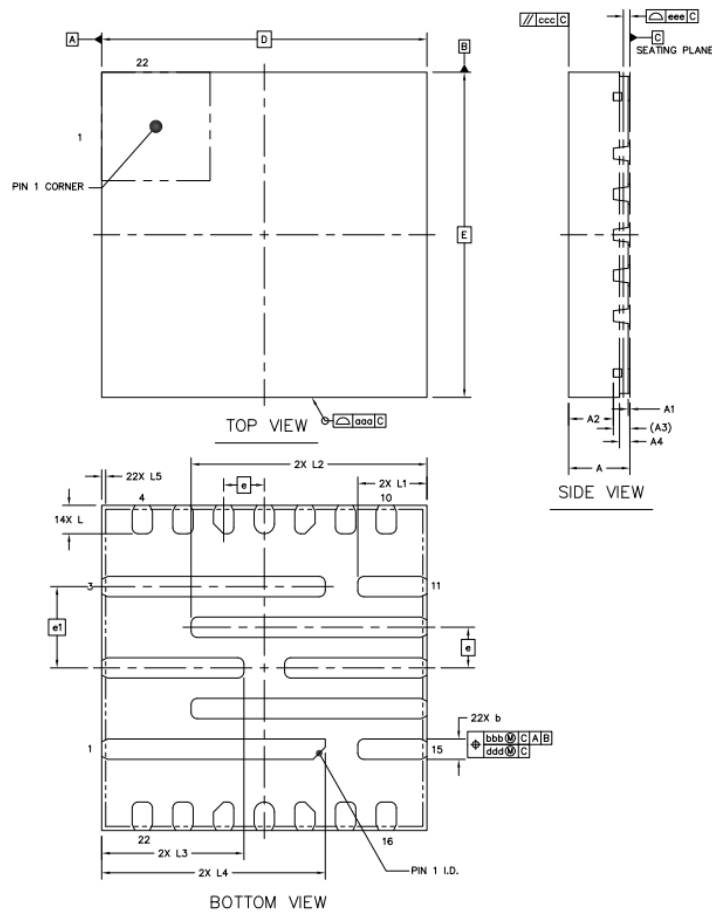

Figure 18. PCB Layout Example

PACKAGE INFORMATION



FCQFN-22L (4x4) Package Outline Dimensions

	SYMBOL	MIN	NOM	MAX
TOTAL THICKNESS	A	0.7	0.75	0.8
STAND OFF	A1	0	0.02	0.05
MOLD THICKNESS	A2	---	0.55	---
L/F THICKNESS	A3		0.203 REF	
SIDE WETTABLE DEPTH	A4	0.075	---	0.18
LEAD WIDTH	b	0.2	0.25	0.3
BODY SIZE	X	D 4 BSC		
	Y	E 4 BSC		
LEAD PITCH	e	0.5 BSC		
	e1	1 BSC		
LEAD LENGTH	L	0.3	0.35	0.4
	L1	0.8	0.85	0.9
	L2	2.85	2.9	2.95
	L3	1.7	1.75	1.8
	L4	2.7	2.75	2.8
SIDE WETTABLE WIDTH	L5	0.01	---	0.09
PACKAGE EDGE TOLERANCE	aaa	0.1		
MOLD FLATNESS	ccc	0.1		
COPLANARITY	eee	0.08		
LEAD OFFSET	bbb	0.1		
	ddd	0.05		

NOTE:

1. Drawing proposed to be made a JEDEC package outline MO-220 variation.
2. Drawing not to scale.
3. All linear dimensions are in millimeters.
4. Thermal pad shall be soldered on the board.
5. Dimensions of exposed pad on bottom of package do not include mold flash.
6. Contact PCB board fabrication for minimum solder mask web tolerances between the pins.

TAPE AND REEL INFORMATION



△
SCALE: 1 : 1

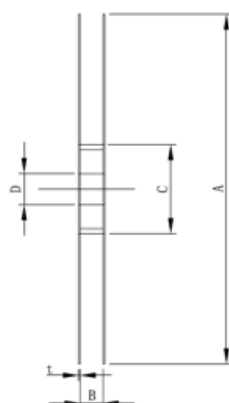

SECTION A-A

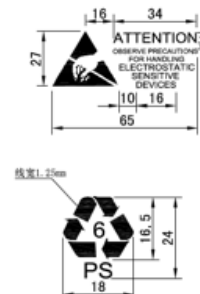

REEL DIMENSIONS

Reel Width	A	B	C	D	t
12	Ø329±1	12.8±1	Ø100±1	Ø13.3±0.3	2.0±0.3

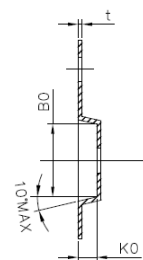
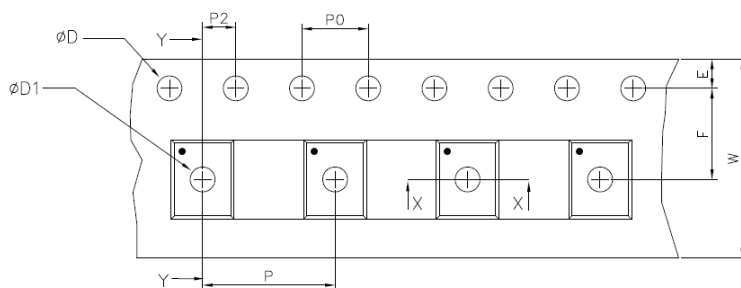

SECTION Y-Y

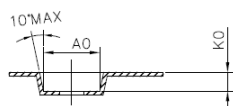

SECTION X-X

TAPE DIMENSIONS

W (mm)	A0 (mm)	B0 (mm)	K0 (mm)	t (mm)	P (mm)
12 ^{+0.30} _{-0.10}	4.40±0.10	4.40±0.10	1.14±0.10	0.25±0.02	8±0.10

E (mm)	F (mm)	P2 (mm)	D (mm)	D1 (mm)	P0 (mm)	10P0 (mm)
1.75±0.10	5.50±0.05	2.00±0.05	1.50 ^{+0.10} ₀	1.50 ^{+0.25} ₀	4.00±0.10	40.0±0.20