

3.8V-36V Vin, 3A Synchronous Step-down DCDC Converter with EMI Reduction

FEATURES

- 3.8V-36V Wide Input Voltage Range
- Up to 3A Continuous Output Load Current
- EMI Reduction
 - Proprietary Gate Design for Switching Node Ringing-free
 - Frequency Spread Spectrum (FSS)
- Pulse Skipping Mode (PSM) with 22uA Quiescent Current in Light Load Condition
 - Up to 81% Efficiency at 1mA Light Load
 - Up to 87% Efficiency at 10mA Light Load
- 0.8V \pm 1% Feedback Reference Voltage
- Fully Integrated 74m Ω R_{ds(on)} High Side MOSFET and 40m Ω R_{ds(on)} Low Side MOSFET
- 1uA Shut-down Current
- 800kHz Switching Frequency
- Precision Enable Threshold for Programmable UVLO Threshold and Hysteresis
- Output Over Voltage Protection
- Thermal Shutdown Protection at 170°C

APPLICATIONS

- Automotive System
- Industrial Control System
- General Consumer

DESCRIPTION

The SCT9433 are 3A synchronous buck converters with up to 36V wide input voltage range, which fully integrates an 74m Ω high-side MOSFET and a 40m Ω low-side MOSFET to provide high efficiency step-down DCDC conversion. The SCT9433 adopts peak current mode control with integrated compensation network. The SCT9433 supports the Pulse Skipping Modulation (PSM) with typical 22uA Ultra-Low Quiescent.

The SCT9433 are optimized for Electromagnetic Interference (EMI) reduction. The converter has proprietary designed gate driver scheme to resist switching node ringing without sacrificing MOSFET turn-on and turn-off time, which further erases high frequency radiation EMI noise caused by the MOSFETs hard switching. The converter features Frequency Spread Spectrum (FSS) with a switching frequency jitter of \pm 6%, which reduces EMI by not allowing emitted energy to stay in any one frequency for a significant period of time.

The SCT9433 offer output over-voltage protection, cycle-by-cycle peak current limit, and thermal shutdown protection. The device is available in a low-profile QFN-9L 3mm X 2mm package.

TYPICAL APPLICATION

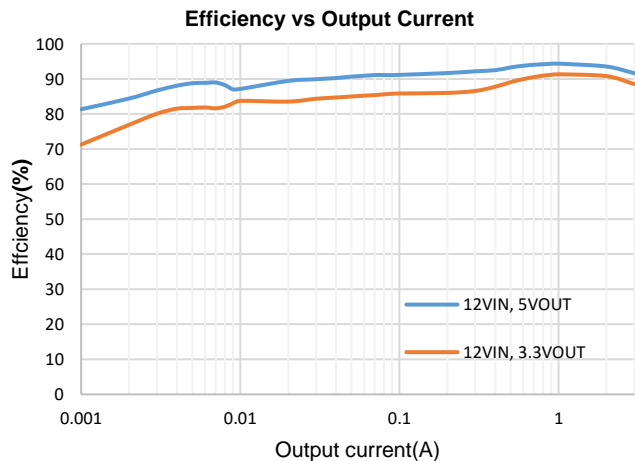
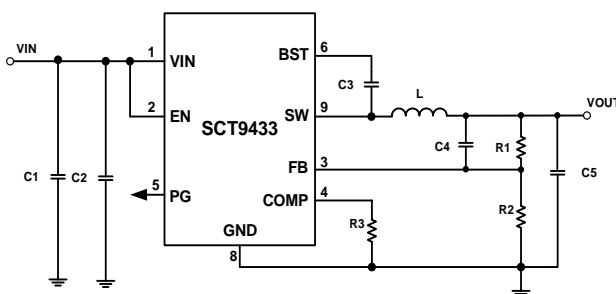

SCT9433

REVISION HISTORY

Revision 1.0: Production.

Revision 1.1: Update EC table.

Revision 1.2: Update Shutdown current in EC table.

Revision 1.3: Update DEVICE ORDER INFORMATION.

Revision 1.4: Add MSL and description of LDO functionality.

DEVICE ORDER INFORMATION

ORDERABLE DEVICE	PACKAGING TYPE	STANDARD PACK QTY	PACKAGE MARKING	PINS	PACKAGE DESCRIPTION	MSL
SCT9433FSAR	Tape & Reel	5000	9433	9	FCQFN2x3-9	1

ABSOLUTE MAXIMUM RATINGS

Over operating free-air temperature unless otherwise noted⁽¹⁾

DESCRIPTION	MIN	MAX	UNIT
BST	-0.3	48	V
VIN, SW, EN	-0.3	40	V
FB, COMP	-0.3	6	V
BST-SW	-0.3	6	V
Operating junction temperature ⁽²⁾	-40	125	°C
Junction temperature	-40	150	°C
Storage temperature T _{STG}	-65	150	°C

PIN CONFIGURATION

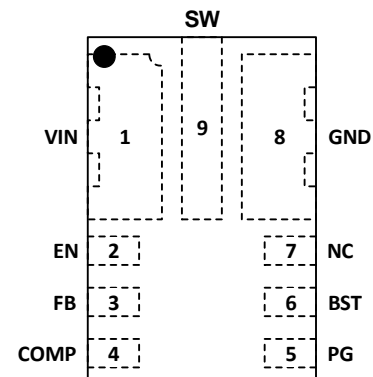

- (1) Stresses beyond those listed under Absolute Maximum Rating may cause device permanent damage. The device is not guaranteed to function outside of its Recommended Operation Conditions.
- (2) The IC includes over temperature protection to protect the device during overload conditions. Junction temperature will exceed 170°C when over temperature protection is active. Continuous operation above the specified maximum operating junction temperature will reduce lifetime.

PIN FUNCTIONS

NAME	NO.	PIN FUNCTION
VIN	1	Power supply input. Must be locally bypassed.
EN	2	Enable logic input. Floating the pin enables the device. This pin supports high voltage input up to VIN supply to be connected VIN directly to enable the device automatically. The device has precision enable thresholds 1.18V rising / 1.1V falling for programmable UVLO threshold and hysteresis.
FB	3	Buck converter output feedback sensing voltage. Connect a resistor divider from VOUT to FB to set up output voltage. The device regulates FB to the internal reference of 0.8V typical.
COMP	4	Compensation pin. Connect this pin to GND with a 1KΩ resistor for internal compensation. Add an RC network to adjust the loop response externally. See Loop Response Design for more details.

PG	5	Open drain power-good output that is pulled to GND when the output voltage is out of its regulation limits or during soft-start. There is an internal 5M Ω pull-up resistor.
BST	6	Power supply for the high-side power MOSFET gate driver. Must connect a 0.1 μ F or greater ceramic capacitor between BST pin and SW node.
NC	7	NC
GND	8	Power ground. Must be soldered directly to ground plane.
SW	9	Switching node of the buck converter.

RECOMMENDED OPERATING CONDITIONS

Over operating free-air temperature range unless otherwise noted

PARAMETER	DEFINITION	MIN	MAX	UNIT
V _{IN}	Input voltage range	3.8	36	V
T _A	Operating Ambient Temperature Range	-40	125	°C
T _J	Operating junction temperature	-40	150	°C

ESD RATINGS

PARAMETER	DEFINITION	MIN	MAX	UNIT
V _{ESD}	Human Body Model(HBM), per ANSI-JEDEC-JS-001-2014 specification, all pins ⁽¹⁾	-2	+2	kV
	Charged Device Model(CDM), per ANSI-JEDEC-JS-002-2014 specification, all pins ⁽¹⁾	-1	+1	kV

THERMAL INFORMATION

PARAMETER	THERMAL METRIC	QFN-9L	UNIT
R _{θJA}	Junction to ambient thermal resistance ⁽¹⁾	61.33	°C/W
Ψ _{JT}	Junction-to-top characterization parameter	3.24	
Ψ _{JB}	Junction-to-board characterization parameter ⁽¹⁾	5.43	
R _{θJctop}	Junction to case(top) thermal resistance ⁽¹⁾	62.99	
R _{θJB}	Junction-to-board thermal resistance ⁽¹⁾	5.6	

(1) SCT provides R_{θJA} and R_{θJC} numbers only as reference to estimate junction temperatures of the devices. R_{θJA} and R_{θJC} are not a characteristic of package itself, but of many other system level characteristics such as the design and layout of the printed circuit board (PCB) on which the SCT9433 is mounted. The PCB board is a heat sink that is soldered to the leads and thermal pad of the SCT9433. Changing the design or configuration of the PCB board changes the efficiency of the heat sink and therefore the actual R_{θJA} and R_{θJC}.

SCT9433

ELECTRICAL CHARACTERISTICS

V_{IN}=12V, T_J=-40°C~150°C, typical value is tested under 25°C.

SYMBOL	PARAMETER	TEST CONDITION	MIN	TYP	MAX	UNIT
Power Supply and Output						
V _{IN}	Operating input voltage		3.8		36	V
V _{IN_UVLO}	Input UVLO	V _{IN} rising	3.3	3.5	3.7	V
	Hysteresis			420		mV
I _{SD}	Shutdown current	EN=0, No load, V _{IN} =12V		0.6	5	uA
I _Q	Quiescent current	EN=floating, No load, No switching. V _{IN} =12V. BST-SW=5V		22	40	uA
Enable, Soft Start and Working Modes						
V _{EN_H}	Enable high threshold		1.08	1.18	1.28	V
V _{EN_L}	Enable low threshold		0.98	1.1	1.18	V
I _{EN_L}	Enable pin input current	EN=1V	1	1.5	2	uA
I _{EN_H}	Enable pin hysteresis current	EN=1.5V		5.5		uA
Power MOSFETs						
R _{DS(on)_H}	High side FET on-resistance			74	130	mΩ
R _{DS(on)_L}	Low side FET on-resistance			40	70	mΩ
Feedback and Error Amplifier						
V _{FB}	Feedback Voltage	T _J =25°C	0.792	0.8	0.808	V
		T _J =-40°C-150°C	0.788	0.8	0.812	
Current Limit						
I _{LIM_HSD}	HSD peak current limit	T _J =25°C	4.0	4.5	5.0	A
		T _J =-40°C-150°C	3.7	4.5	5.3	
I _{LIM_LSD}	LSD valley current limit			4		A
Switching Frequency						
F _{SW}	Switching frequency	V _{IN} =12V, V _{OUT} =5V	680	800	920	kHz
t _{ON_MIN}	Minimum on-time			100		ns
Soft Start Time						
t _{SS}	Internal soft-start time			4		ms
Protection						
V _{OVP}	Output OVP threshold	V _{OUT} rising		110		%
		Hysteresis		5		%
T _{SD}	Thermal shutdown threshold*	T _J rising		170		°C
		Hysteresis		25		

*Derived from bench characterization

TYPICAL CHARACTERISTICS

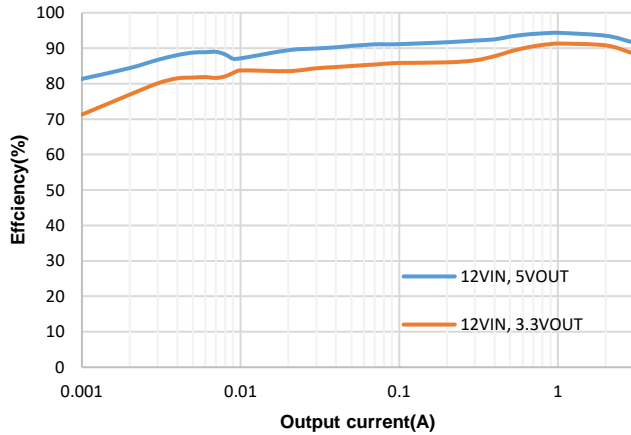

Figure 1. Efficiency vs Load Current

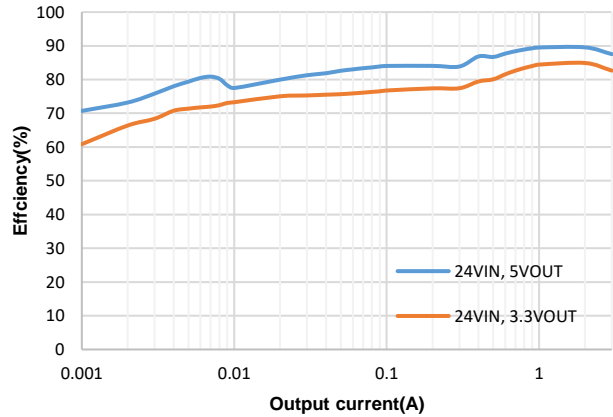

Figure 2. Efficiency vs Load Current

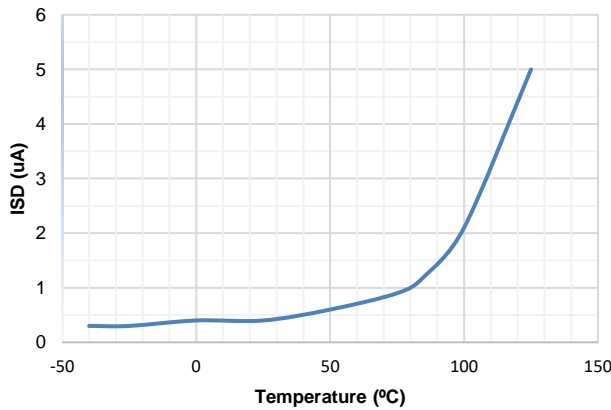

Figure 3. Shut-down Current vs Temperature

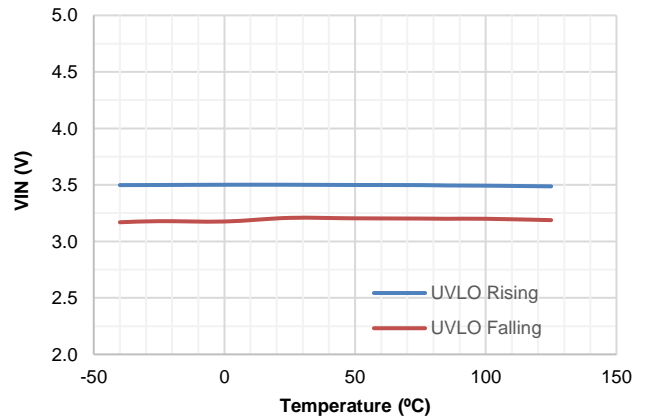

Figure 4. VIN UVLO vs Temperature

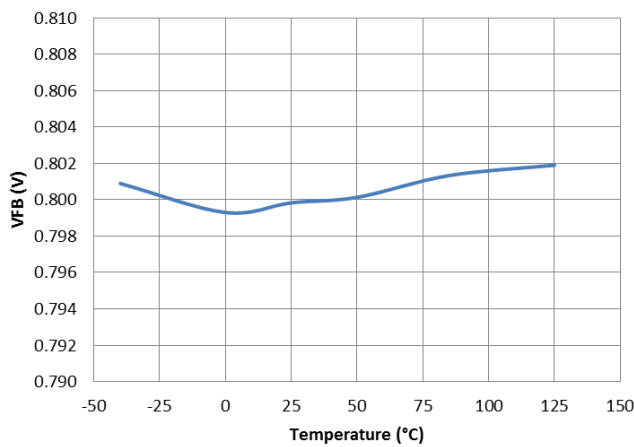

Figure 5. Reference Voltage vs Temperature

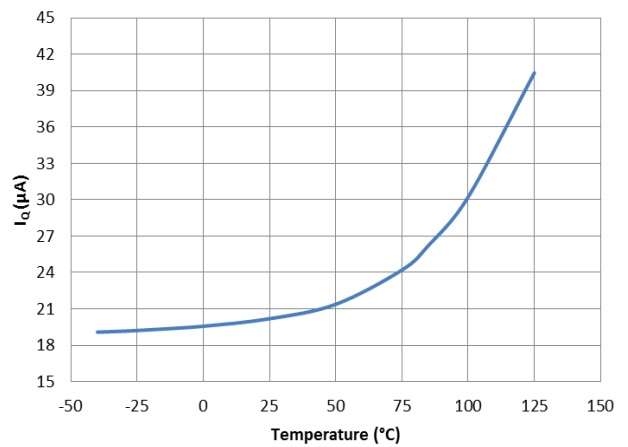

Figure 6. IQ vs. Temperature, IOU = 0A

FUNCTIONAL BLOCK DIAGRAM

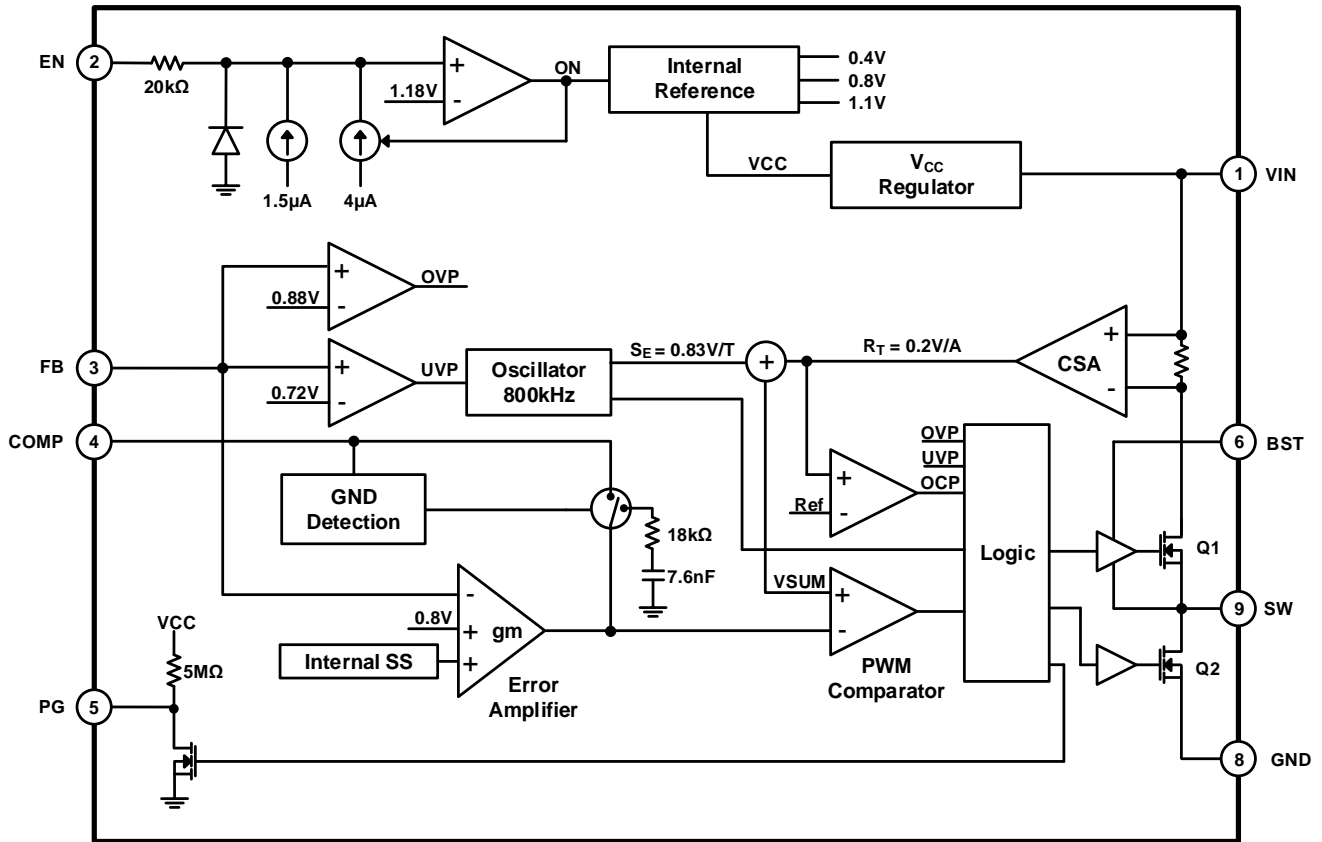

Figure 7. Functional Block Diagram

OPERATION

Overview

The SCT9433 device is 3.8V-36V input, 3A output, EMI friendly, fully integrated synchronous buck converters. The device employs fixed frequency peak current mode control. An internal clock with 800kHz frequency initiates turning on the integrated high-side power MOSFET Q1 in each cycle, then inductor current rises linearly and the converter charges output cap. When sensed voltage on high-side MOSFET peak current via the CSA block, rising above the voltage of internal COMP (see functional block diagram), the device turns off high-side MOSFET Q1 and turns on low-side MOSFET Q2. The inductor current decreases when MOSFET Q2 is ON. In the next rising edge of clock cycle, the low-side MOSFET Q2 turns off. This repeats on cycle-by-cycle based.

The internal loop compensation network and the built-in 4ms soft-start simplify the SCT9433 footprints, and minimize the off-chip component counts. The quiescent current of SCT9433 is 22uA typical under no-load condition and no switching. When disabling the device, the shutdown current of SCT9433 is only 1uA. The SCT9433 works at Pulse Skipping Mode PSM to further increase the power efficiency in light load condition, hence the power efficiency can be achieved up to 89% at 5mA load condition.

The error amplifier serves the COMP node by comparing the voltage on the FB pin with an internal 0.8V reference voltage. When the load current increases, a reduction in the feedback voltage relative to the reference raises COMP voltage till the average inductor current matches the increased load current. This feedback loop well regulates the output voltage. The device also integrates an internal slope compensation circuitry to prevent sub-harmonic oscillation when duty cycle is greater than 50% for a fixed frequency peak current mode control.

The SCT9433 device implements Frequency Spread Spectrum (FSS) with a switching frequency jitter of $\pm 6\%$. FSS reduces EMI by not allowing emitted energy to stay in any one frequency for a significant period of time. The converter further dampens high frequency radiated EMI noise through the use of its proprietary gate driver scheme to achieve a ringing-free switching node voltage without sacrificing the MOSFET switching times.

The hiccup mode minimizes power dissipation during prolonged output overcurrent or short conditions. The hiccup wait time is 512 cycles and the hiccup restart time is 8192 cycles. The SCT9433 device also features protections including cycle-by-cycle high-side MOSFET peak current limit, over-voltage protection, and over-temperature protection.

PSM Working Modes

In heavy load condition, the SCT9433 forces the device operating at PWM mode. When the load current decreasing, the internal COMP net voltage decreases as the inductor current down. With the load current further decreasing, the COMP net voltage decreases and be clamped at a voltage corresponding to the 600mA peak inductor current. When the load current approaches zero, the SCT9433 enter Pulse Skipping Mode (PSM) mode to increase the converter power efficiency at light load condition. When the inductor current decreases to zero, zero-cross detection circuitry on high-side MOSFET Q1 forces the Q1 off till the beginning of the next switching cycle. The buck converter does not sink current from the load when the output load is light and converter works in PSM mode.

VIN Power

The SCT9433 is designed to operate from an input voltage supply range between 3.8V to 36V. At least a 0.1uF decoupling ceramic cap is recommended to bypass the supply noise. If the input supply locates more than a few inches from the converter, an additional electrolytic or tantalum bulk capacitor or with recommended 22uF may be required in addition to the local ceramic bypass capacitors.

Under Voltage Lockout UVLO

The SCT9433 Under Voltage Lock Out (UVLO) default startup threshold is typical 3.5V with VIN rising and shutdown threshold is 3.1V with VIN falling. The more accurate UVLO threshold can be programmed through the precision enable threshold of EN pin.

Enable and Start up

When applying a voltage higher than the EN high threshold (typical 1.18V/rise), the SCT9433 enables all functions and the device starts soft-start phase. The SCT9433 has the built in 4ms soft-start time to prevent the output overshoot and inrush current. When EN pin is pulled low, the internal SS net will be discharged to ground. Buck operation is disabled when EN voltage falls below its lower threshold (typically 1.1V/fall).

An internal 1.5uA pull up current source connected from internal LDO power rail to EN pin guarantees that floating EN pin automatically enables the device. For the application requiring higher VIN UVLO voltage than the default setup, there is a 4uA hysteresis pull up current source on EN pin which configures the VIN UVLO voltage with an off-chip resistor divider R3 and R4, shown in Figure 8. The resistor divider R3 and R4 are calculated by equation (1) and (2).

EN pin is a high voltage pin and can be directly connected to VIN to automatically start up the device with VIN rising to its internal UVLO threshold.

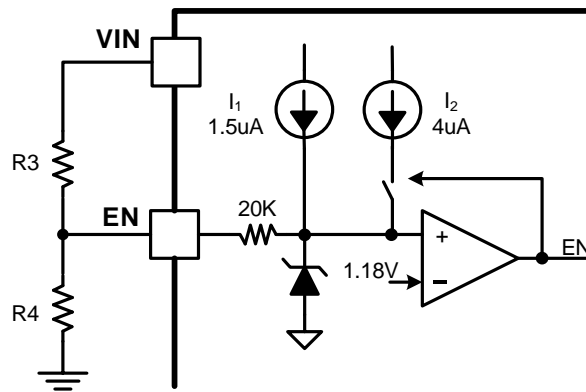

Figure 8. Adjustable VIN UVLO

$$R3 = \frac{V_{Start} \left(\frac{V_{ENF}}{V_{ENR}} \right) - V_{Stop}}{I_1 \left(1 - \frac{V_{ENF}}{V_{ENR}} \right) + I_2} \quad (1)$$

$$R4 = \frac{R3 \times V_{ENF}}{V_{Stop} - V_{ENF} + R3(I_1 + I_2)} \quad (2)$$

Where:

- V_{start} : Vin rise threshold to enable the device
- V_{stop} : Vin fall threshold to disable the device
- $I_1=1.5\mu A$
- $I_2=4\mu A$
- $V_{ENR}=1.18V$
- $V_{EMF}=1.1V$

Power-GOOD (PG) Indicator

The SCT9433 has an open-drain output that is actively held low during soft start period until the output voltage reaches 90% of the target output. When the output voltage is outside of its regulation by -10%, the PG will pull low until the output returns to set value. The PG low to high transition is delayed by 2.5ms while the falling edge PG is

delayed by 220 μ s to prevent false triggering.

Peak Current Limit and Hiccup Mode

The SCT9433 have cycle-by-cycle peak current limit with sensing the internal high side MOSFET Q1 current during overcurrent condition. While the Q1 turns on, its conduction current is monitored by the internal sensing circuitry. Once the high-side MOSFET Q1 current exceeds the limit, it turns off immediately. If the Q1 over current time exceeds 512 switching cycles (hiccup waiting time), the buck converter enters hiccup mode and shuts down. After 8192 cycles off, the buck converter restarts to power up. The hiccup modes reduce the power dissipation in over current condition.

Over Voltage Protection and Minimum On-time

Both SCT9433 feature output over voltage protection (OVP). If the output feedback pin voltage exceeds 110% of feedback reference voltage, the converter stops switching immediately. When the output feedback pin voltage drops below 105% of feedback reference voltage, the converter resumes to switching. The OVP function prevents the connected output circuitry damaged from un-predictive overvoltage. Featured feedback overvoltage protection also prevents dynamic voltage spike to damage the circuitry at load during fast loading transient.

The high-side MOSFET Q1 has minimum on-time 100ns typical limitation. While the device operates at minimum on-time, further increasing VIN results in pushing output voltage beyond regulation point. With output feedback over voltage protection, the converter skips pulse by turning off high-side MOSFET Q1 and prevents output running away higher to damage the load.

Bootstrap Voltage Regulator

An external bootstrap capacitor between BST and SW pin powers floating high-side power MOSFET gate driver. The bootstrap capacitor voltage is charged from an integrated voltage regulator when high-side power MOSFET is off and low-side power MOSFET is on.

The floating supply (BST to SW) UVLO threshold is 2.7V rising and hysteresis of 350mV. When the converter operates with high duty cycle or prolongs in sleep mode for certain long time, the required time interval to recharging bootstrap capacitor is too long to keep the voltage at bootstrap capacitor sufficient. When the voltage across bootstrap capacitor drops below 2.35V, BST UVLO occurs. The SCT9433 intervenes to turn on low side MOSFET periodically to refresh the voltage of bootstrap capacitor to guarantee operation over a wide duty range.

Low Drop-out Operation

During the condition of ultra-low voltage difference from the input to the output, SCT9433 operates in Low Drop-Out LDO mode. High-side MOSFET remains turning on as long as the BST pin to SW pin voltage is higher than BST UVLO threshold 2.7V. When the voltage from BST to SW drops below 2.35V, the high-side MOSFET turns off and low-side MOSFET turns on to recharge bootstrap capacitor periodically in the following several switching cycles. Low-side MOSFET turns on for at least 100ns in each refresh cycle to minimize the output voltage ripple. Low-side MOSFET may turn on for several times till the bootstrap voltage is charged to higher than 2.7V for high-side MOSFET working normally. The effective duty cycle of the converter during LDO operation can be approaching to 100%.

During slowing power up and power down application, the output voltage can closely track the input voltage ramping down thanks to LDO operation mode. As the input voltage is reduced to near the output voltage, i.e. during slowing power-up and power-down application, the off-time of the high side MOSFET starts to approach the minimum value. Without LDO operation mode, beyond this point the switching may become erratic and/or the output voltage will fall out of regulation. To avoid this problem the SCT9433 LDO mode automatically reduces the switching frequency to increase the effective duty cycle and maintain regulation.

EMI Reduction with Switching Node Ringing-free

In buck converter, the switching node ringing amplitude and cycles are critical especially related to the high frequency radiation EMI noise. The SCT9433 implements the multi-level gate driver speed technique to achieve the switching node ringing-free without scarifying the switching node rise/fall slew rate and power efficiency of the

SCT9433

converter. The switching node ringing amplitude and cycles are damped by the built-in MOSFETs gate driving technique (SCT Patented Proprietary Design).

Thermal Shutdown

Once the junction temperature in the SCT9433 exceeds 170°C, the thermal sensing circuit stops converter switching and restarts with the junction temperature falling below 145°C. Thermal shutdown prevents the damage on device during excessive heat and power dissipation condition.

APPLICATION INFORMATION

Typical Application

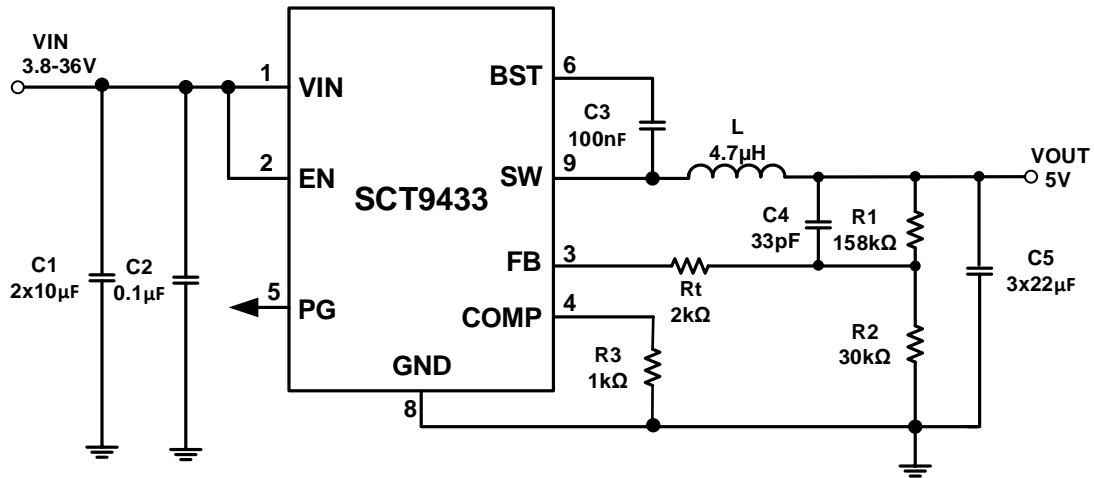

Figure 9. 12V Input, 5V/3A Output with Internal Compensation

Design Parameters

Design Parameters	Example Value
Input Voltage	12V
Output Voltage	5V
Output Current	3A
Output voltage ripple (peak to peak)	±0.03V
Switching Frequency	800kHz

Input Capacitor Selection

For good input voltage filtering, choose low-ESR ceramic capacitors. A ceramic capacitor 10µF is recommended for the decoupling capacitor and a 0.1µF ceramic bypass capacitor is recommended to be placed as close as possible to the VIN pin of the SCT9433.

Use Equation (3) to calculate the input voltage ripple:

$$\Delta V_{IN} = \frac{I_{OUT}}{C_{IN} \times f_{SW}} \times \frac{V_{OUT}}{V_{IN}} \times \left(1 - \frac{V_{OUT}}{V_{IN}}\right) \quad (3)$$

Where:

- C_{IN} is the input capacitor value
- f_{sw} is the converter switching frequency
- I_{OUT} is the maximum load current

Due to the inductor current ripple, the input voltage changes if there is parasitic inductance and resistance between the power supply and the VIN pin. It is recommended to have enough input capacitance to make sure the input voltage ripple less than 100mV. Generally, a 35V/10uF input ceramic capacitor is recommended for most of applications. Choose the right capacitor value carefully with considering high-capacitance ceramic capacitors DC bias effect, which has a strong influence on the final effective capacitance.

Inductor Selection

The performance of inductor affects the power supply's steady state operation, transient behavior, loop stability, and buck converter efficiency. The inductor value, DC resistance (DCR), and saturation current influences both efficiency and the magnitude of the output voltage ripple. Larger inductance value reduces inductor current ripple and therefore leads to lower output voltage ripple. For a fixed DCR, a larger value inductor yields higher efficiency via reduced RMS and core losses. However, a larger inductor within a given inductor family will generally have a greater series resistance, thereby counteracting this efficiency advantage.

Inductor values can have ±20% or even ±30% tolerance with no current bias. When the inductor current approaches saturation level, its inductance can decrease 20% to 35% from the value at 0-A current depending on how the inductor vendor defines saturation. When selecting an inductor, choose its rated current especially the saturation current larger than its peak current during the operation.

To calculate the current in the worst case, use the maximum input voltage, minimum output voltage, maximum load current and minimum switching frequency of the application, while considering the inductance with -30% tolerance and low-power conversion efficiency.

For a buck converter, calculate the inductor minimum value as shown in equation (4).

$$L_{INDMIN} = \frac{V_{OUT} \times (V_{INMAX} - V_{OUT})}{V_{INMAX} \times K_{IND} \times I_{OUT} \times f_{SW}} \quad (4)$$

Where:

- K_{IND} is the coefficient of inductor ripple current relative to the maximum output current.

Therefore, the peak switching current of inductor, I_{LPEAK} , is calculated as in equation (5).

$$I_{LPEAK} = I_{OUT} + K_{IND} \times \frac{I_{OUT}}{2} \quad (5)$$

Set the current limit of the SCT9433 higher than the peak current I_{LPEAK} and select the inductor with the saturation current higher than the current limit. The inductor's DC resistance (DCR) and the core loss significantly affect the efficiency of power conversion. Core loss is related to the core material and different inductors have different core

loss. For a certain inductor, larger current ripple generates higher DCR and ESR conduction losses and higher core loss.

Output Capacitor Selection

For buck converter, the output capacitor value determines the regulator pole, the output voltage ripple, and how the regulator responds to a large change in load current. The output capacitance needs to be selected based on the most stringent of these three criteria.

For small output voltage ripple, choose a low-ESR output capacitor like a ceramic capacitor, for example, X5R and X7R family. Typically, 1~2x 22μF ceramic output capacitors work for most applications. Higher capacitor values can be used to improve the load transient response. Due to a capacitor's de-rating under DC bias, the bias can significantly reduce capacitance. Ceramic capacitors can lose most of their capacitance at rated voltage. Therefore, leave margin on the voltage rating to ensure adequate effective capacitance.

From the required output voltage ripple, use the equation (6) to calculate the minimum required effective capacitance, C_{OUT} .

$$C_{OUT} = \frac{\Delta I_{LPP}}{8 \times V_{OUTRipple} \times f_{SW}} \quad (6)$$

Where

- $V_{OUTRipple}$ is output voltage ripple caused by charging and discharging of the output capacitor.
- ΔI_{LPP} is the inductor peak to peak ripple current, equal to $k_{IND} \cdot I_{OUT}$.
- f_{SW} is the converter switching frequency.

The allowed maximum ESR of the output capacitor is calculated by the equation (7).

$$R_{ESR} = \frac{V_{OUTRipple}}{\Delta I_{LPP}} \quad (7)$$

The output capacitor affects the crossover frequency f_c . Considering the loop stability and effect of the internal loop compensation parameters, choose the crossover frequency less than 80 kHz ($\frac{1}{10} \times f_{SW}$) without considering the feed-forward capacitor. A simple estimation for the crossover frequency without feed forward capacitor is shown in equation (8), assuming C_{OUT} has small ESR.

$$C_{OUT} > \frac{18k \times G_M \times G_{MP} \times 0.8V}{2\pi \times V_{OUT} \times f_c} \quad (8)$$

Where

- G_M is the transfer conductance of the error amplifier (300uS).
- G_{MP} is the gain from internal COMP to inductor current, which is 5A/V.
- f_c is the cross over frequency.

Additional capacitance de-rating for aging, temperature and DC bias should be factored in which increases this minimum value. Capacitors generally have limits to the amount of ripple current they can handle without failing or producing excess heat. An output capacitor that can support the inductor ripple current must be specified. The capacitor data sheets specify the RMS (Root Mean Square) value of the maximum ripple current. Equation (9) can be used to calculate the RMS ripple current the output capacitor needs to support.

$$I_{COUTRMS} = \frac{V_{OUT} \cdot (V_{IN} - V_{OUT})}{\sqrt{12} \cdot V_{IN} \cdot L_{IND} \cdot f_{SW}} \quad (9)$$

Output Feed-Forward Capacitor Selection

The SCT9433 has the internal integrated loop compensation as shown in the function block diagram. The compensation network includes a 18k resistor and a 7.6nF capacitor. Usually, the type II compensation network has a phase margin between 60 and 90 degree. However, if the output capacitor has ultra-low ESR, the converter results in low phase margin. To increase the converter phase margin, a feed-forward cap C_{ff} is used to boost the phase margin at the converter cross-over frequency f_c . Equation (10) is used to calculate the feed-forward capacitor.

$$C_{ff} = \frac{1}{2\pi \cdot f_c \times R_1} \quad (10)$$

Output Feedback Resistor Divider Selection

The SCT9433 features external programmable output voltage by using a resistor divider network R1 and R2 as shown in the typical application circuit Figure 9. Use equation (11) to calculate the resistor divider values.

$$R_1 = \frac{(V_{OUT} - V_{ref}) \times R_2}{V_{ref}} \quad (11)$$

Set the resistor R2 value to be approximately 30k. Slightly increasing or decreasing R1 can result in closer output voltage matching when using standard value resistors.

Table 1 is the recommend external components for the application with integrated loop compensation for SCT9433.

Table 1. Recommended External Components with Internal Compensation

Vout	L1	COUT	R1	R2	Rt	R3	C4
3.3V	3.3uH	3*22uF	95k	30k	2k	1k	47pF
5V	4.7uH	3*22uF	158k	30k	2k	1k	33pF
12V	10uH	4*22uF	422k	30k	2k	1k	/

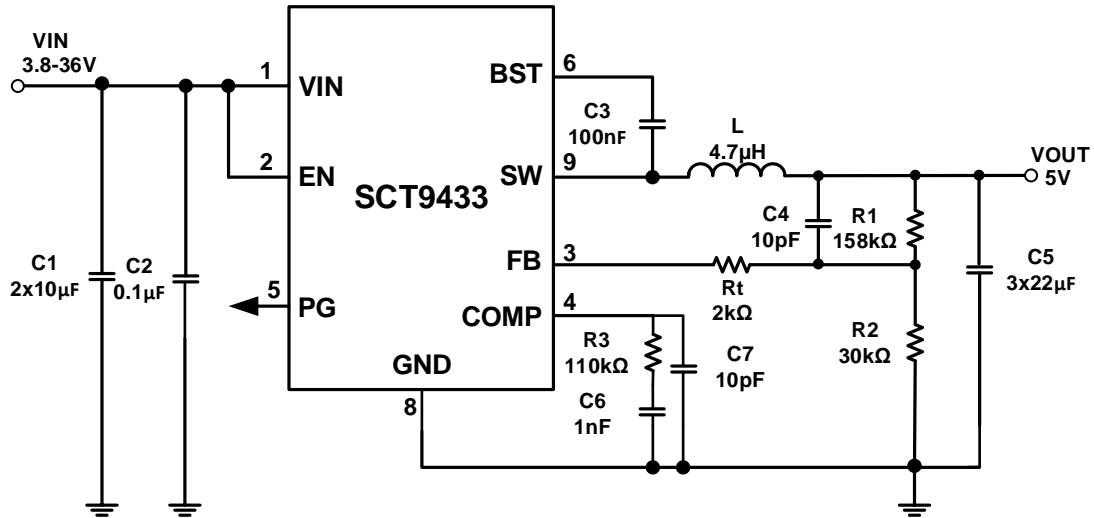

Figure 10. 12V Input, 5V/3A Output with External Compensation

Loop Response Design

When the COMP pin is not connected to GND, the COMP pin is active for external loop compensation. The regulator uses constant frequency peak current mode control architecture to achieve a fast loop response. The inductor is not considered as a state variable since its peak current is constant. The system becomes a single order system. It is much easier to design a type II compensator (Figure 12) to stabilize the loop than in case of a voltage mode control. Peak current mode control has an inherent input voltage feed-forward function to achieve good line regulation. Figure 11 shows the small signal model of the synchronous buck regulator.

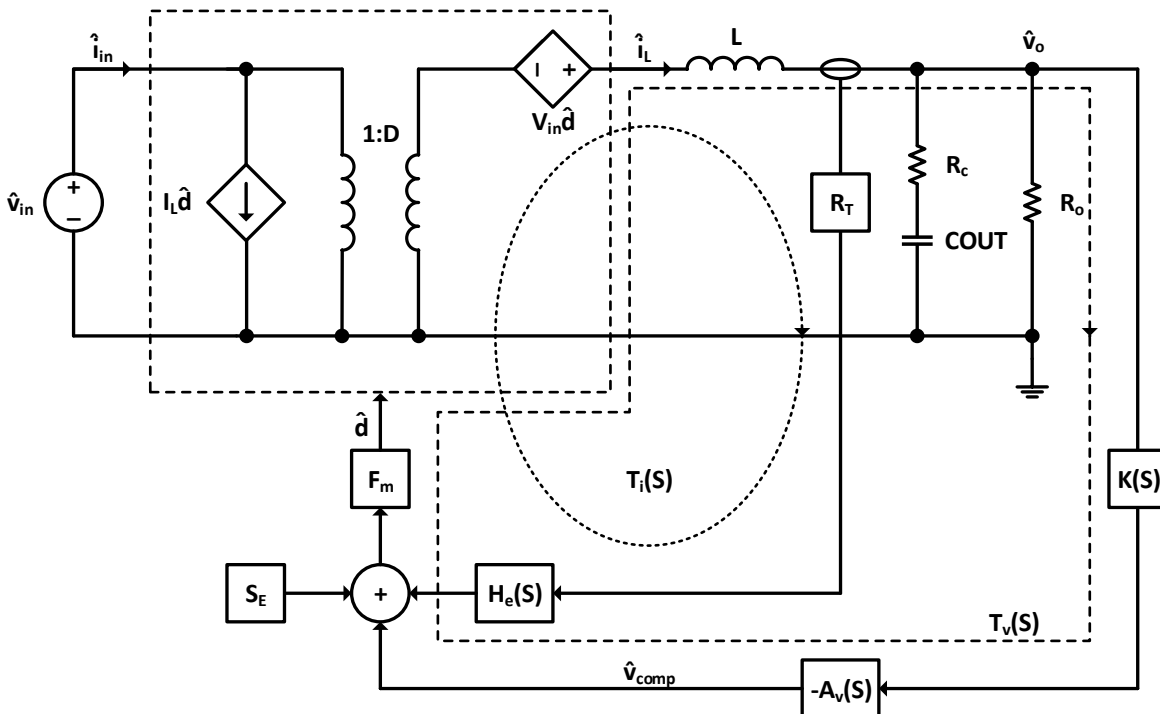

Figure 11. Small Signal Model of Buck Regulator

Where:

- $T_v(S)$ is the voltage loop
- $T_i(S)$ is the current loop
- $K(S)$ is the voltage sense gain
- $-A_v(S)$ is the feedback compensation gain
- $H_e(S)$ is the current sampling function
- F_m is the PWM comparator gain
- V_{in} is the DC input voltage
- D is the duty cycle
- R_c is the ESR of the output capacitor, C_{OUT}
- R_o is the output load resistance \hat{v}_{in} is the AC small-signal input voltage
- \hat{i}_{in} is the AC small-signal input current
- \hat{d} is the modulation of the duty cycle
- \hat{i}_L is the AC small signal of the inductor current
- \hat{v}_o is the AC small signal of output voltage
- \hat{v}_{comp} is the AC small signal voltage of the compensation network

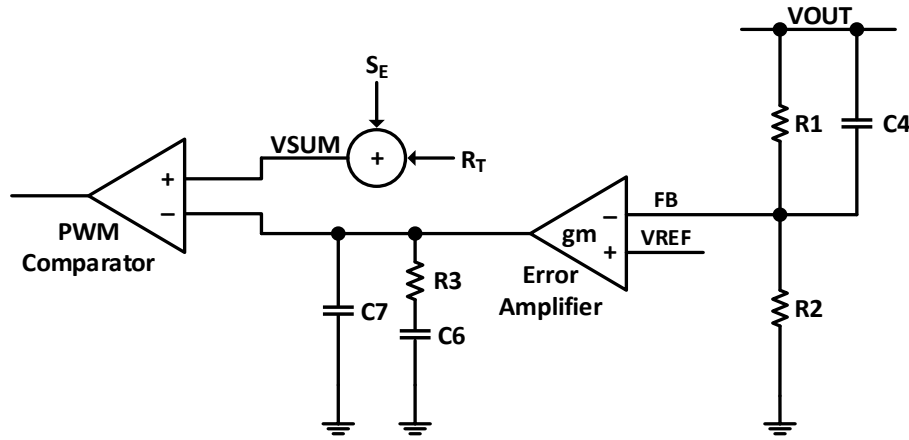

Figure 12. Type II Compensator

Transfer function of Figure 12 is expressed in the following equation,

$$A(S) = \frac{\hat{V}_{COMP}}{\hat{V}_{FB}} = \frac{gm \cdot R3}{(C6 + C7) \cdot (R1 + R2)} \frac{\left(1 + \frac{s}{\omega_{z1}}\right) \left(1 + \frac{s}{\omega_{z2}}\right)}{s \cdot \left(1 + \frac{s}{\omega_{p1}}\right) \left(1 + \frac{s}{\omega_{p2}}\right)} \quad (12)$$

Where:

$$\omega_{z1} = \frac{1}{R3 \cdot C6}$$

$$\omega_{z2} = \frac{1}{R1 \cdot C4}$$

$$\omega_{p1} = \frac{C6 + C7}{R3 \cdot C6 \cdot C7}$$

$$\omega_{p2} = \frac{R1 + R2}{R1 \cdot R2 \cdot C4}$$

The goal of loop compensation design is to achieve:

- High DC Gain
- Gain Margin less than -10dB
- Phase Margin greater than 45°
- Loop Bandwidth Crossover Frequency (f_c) less than 80kHz (10% of f_{sw})

The loop gain at crossover frequency of f_c has a unity gain. Therefore, the compensator resistance $R3$ is determined by equation below. A recommended rule of thumb is to set the crossover frequency to be approximately 1/5 to 1/10 of switching frequency.

$$R3 = \frac{2\pi \cdot f_c \cdot V_{out} \cdot C_o \cdot R_t}{g_m \cdot VFB} \tag{13}$$

Where

- $g_m=0.3mS$,
- $R_t=0.2V/A$
- $VFB=0.8V$,
- f_c is the desired crossover frequency
- V_{out} is the output voltage
- C_o is the effective output capacitance.

Be cautioned that most ceramic will degrade with voltage stress or temperature extremes.

The compensator capacitor $C6$ and $C7$ are then equal to:

$$C6 = \frac{V_{out} \cdot C_o}{I_o \cdot R3}, \quad C7 = \max \left[\frac{R_c \cdot C_o}{R3}, \frac{1}{\pi \cdot f_{sw} \cdot R3} \right] \tag{14}$$

Where :

- I_o is the output load current
- R_c is the ESR equivalent of the C_o
- F_s is the switching frequency. In most cases, $C7$ can omit.

An optional zero, ω_{z2} , can boost the phase margin but it can also increase the gain crossover. Place this zero at 2 to 5 times the f_c . Then $C4$ is equal to:

$$C4 = \frac{1}{10\pi \cdot f_c \cdot R1} \text{ to } \frac{1}{4\pi \cdot f_c \cdot R1} \tag{15}$$

Table 2. Recommended External Components with External Compensation

Vout	L1	COU	R1	R2	Rt	C4	R3	C6	C7
3.3V	3.3uH	3*22uF	95k	30k	2k	10pF	78.7k	1nF	15pF
5V	4.7uH	3*22uF	158k	30k	2k	10pF	110k	1nF	10pF
12V	10uH	3*22uF	422k	30k	2k	22pF	150k	1.5nF	47pF

Application Waveforms

Vin=12V, Vout=5V, unless otherwise noted

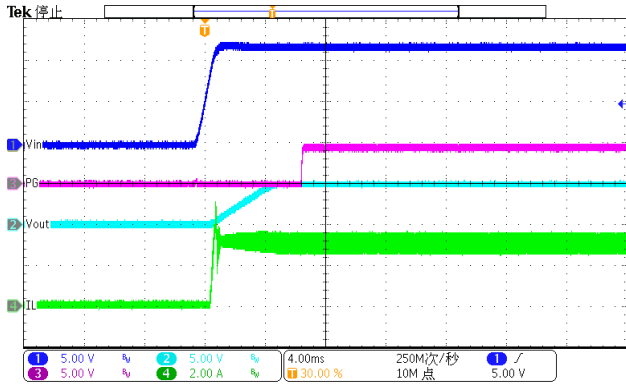

Figure 13. Power up(Iload=3A)

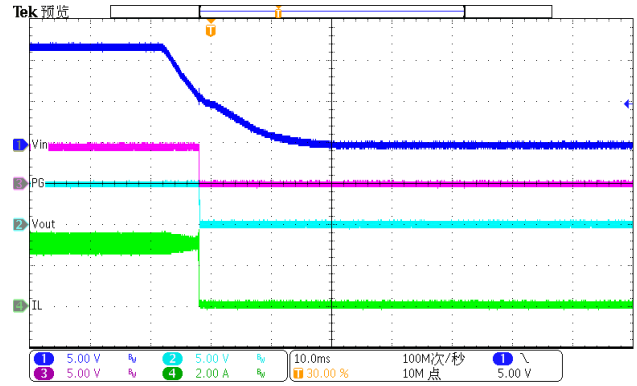

Figure 14. Power down(Iload=3A)

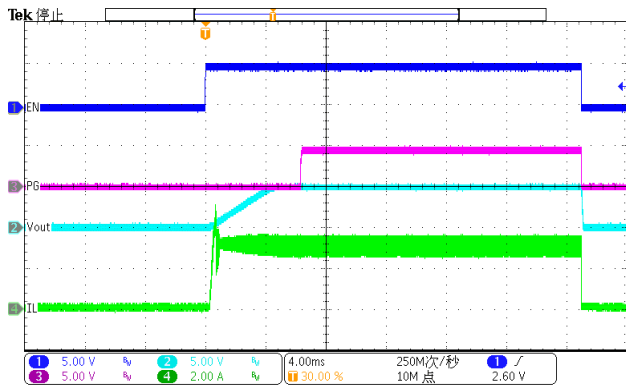

Figure 15. Enable (Iload=3A)

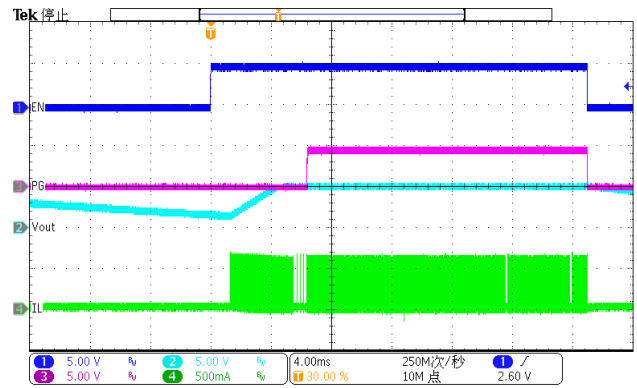

Figure 16. Enable (Iload=10mA)

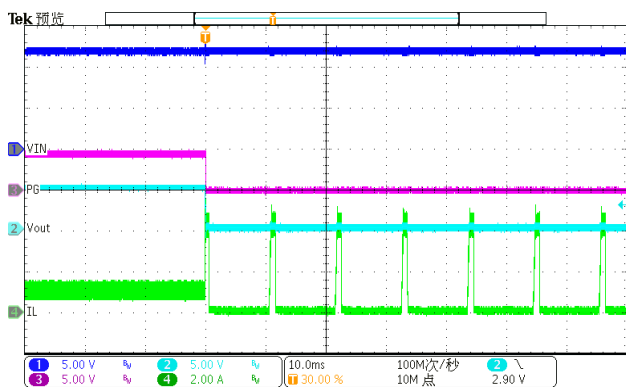

Figure 17. Normal to Hard Short

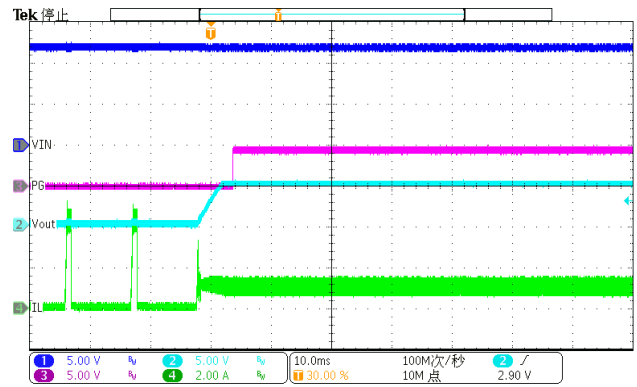

Figure 18. Hard Short Recovery

Application Waveforms(continued)

Vin=12V, Vout=5V, unless otherwise noted

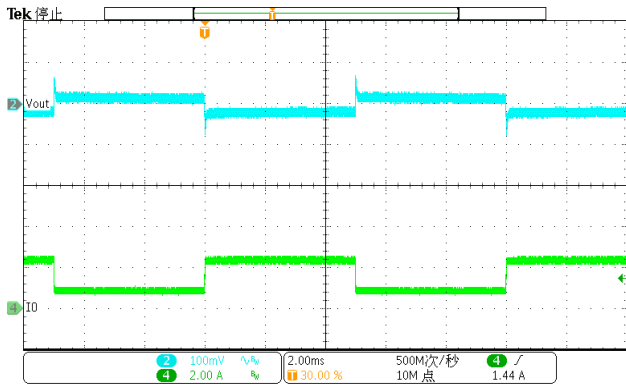

Figure 19. Load Transient (0.75A-2.25A, 1.6A/us)

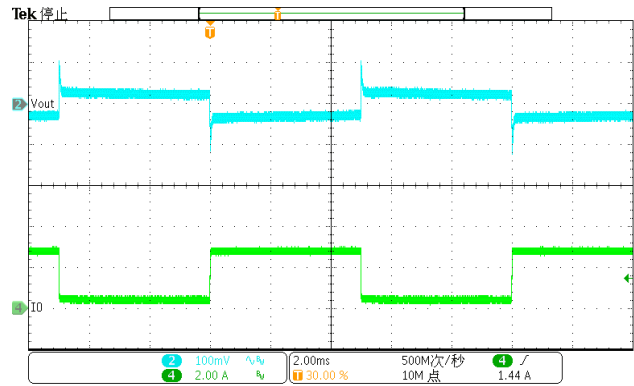

Figure 20. Load Transient (0.3A-2.7A, 1.6A/us)

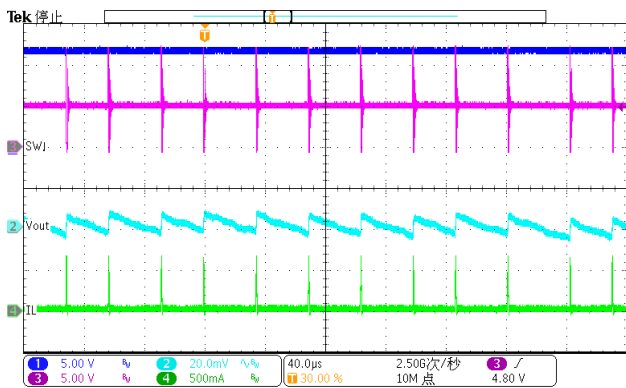

Figure 21. Output Ripple (Iload=10mA)

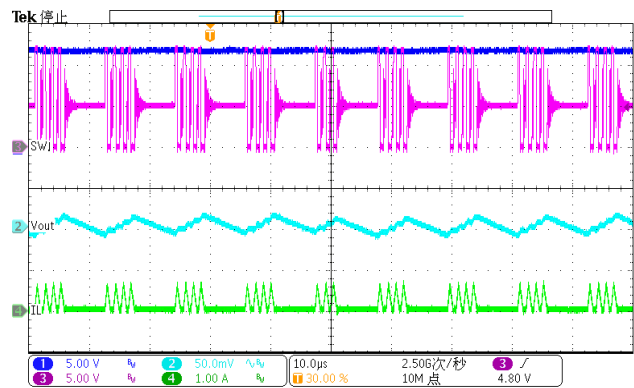

Figure 22. Output Ripple (Iload=0.1A)

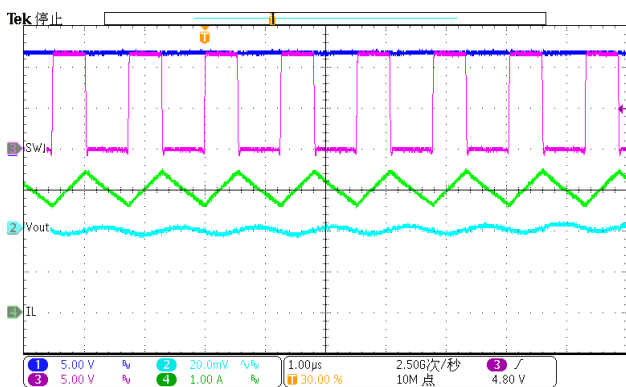

Figure 23. Output Ripple (Iload=3A)

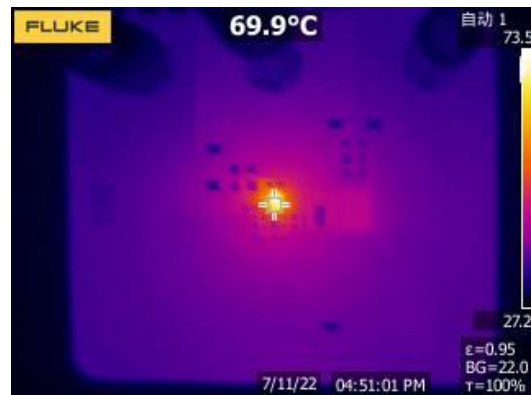

Figure 24. Thermal, 12VIN, 5Vout, 3A

Layout Guideline

Figure 25 and Figure 26 are the recommended PCB layout of SCT9433 with or without external compensation network.

1. The SCT9433 works at 3A load current so heat dissipation is a major concern in the layout of the PCB. 2oz copper for both the top and bottom layers is recommended.
2. Place the input capacitors as closely across VIN and GND as possible.
3. Place the inductor as close to SW as possible.
4. Place the output capacitors as close to GND as possible.
5. Place the feedback components as close to FB as possible.
6. If using four or more layers, use at least the 2nd and 3rd layers as GND to maximize thermal performance.
7. Add as many vias under both the thermally exposed GND pad and GND plane for heat dissipation to all the GND layers.
8. Add as many vias under both the thermally exposed VIN pad and VIN plane for heat dissipation to all the VIN layers.

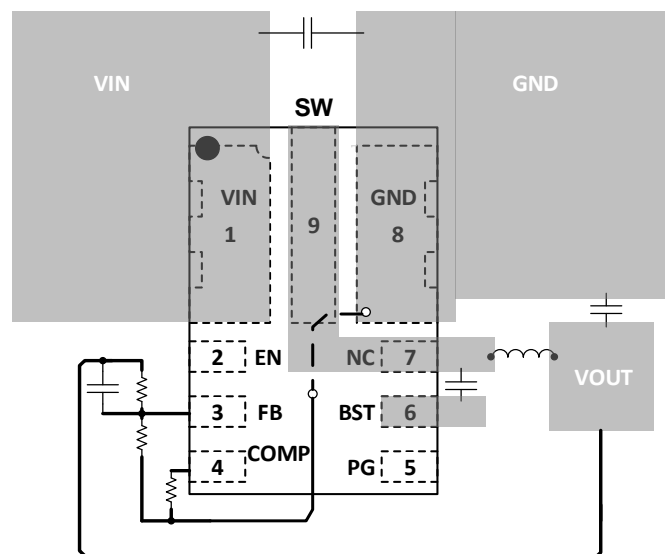

Figure 25. PCB Layout Example for application with internal compensation

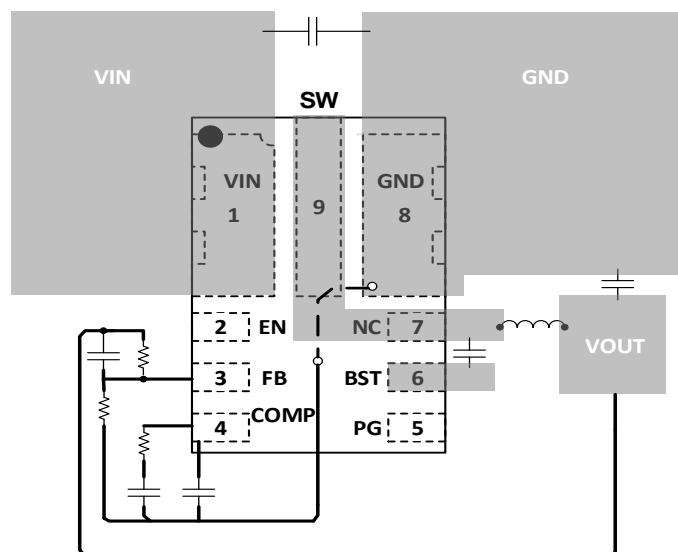
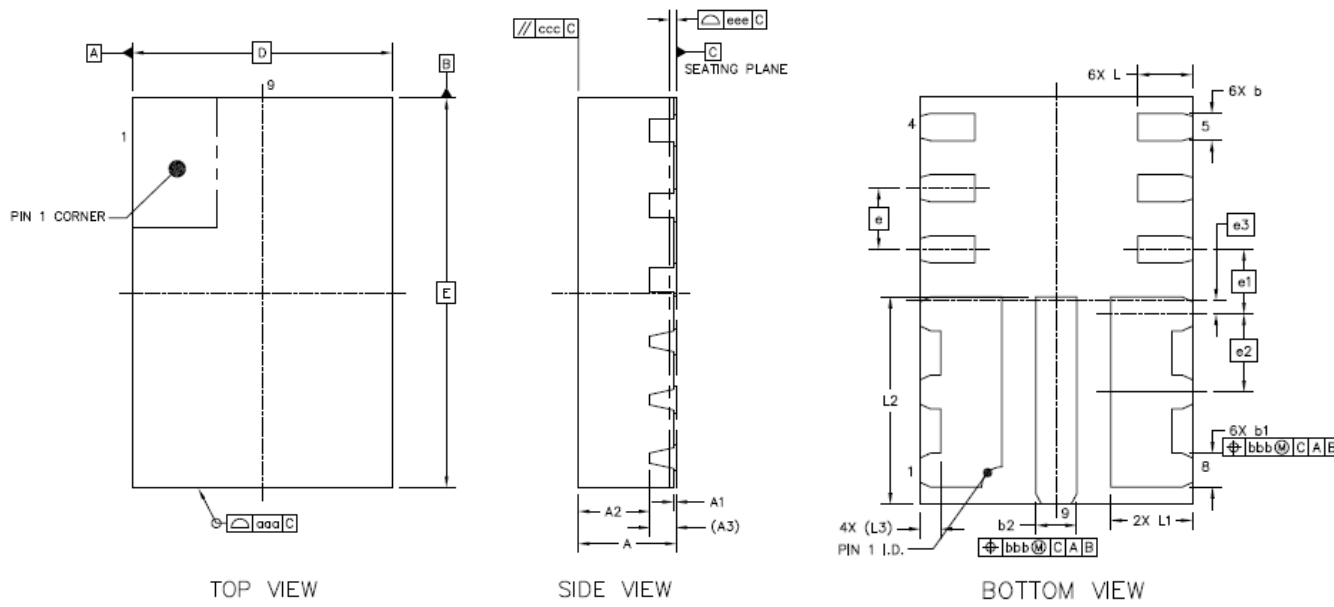

Figure 26. PCB Layout Example for application with external compensation

PACKAGE INFORMATION



FCQFN-9L (2*3) Package Outline Dimensions

Symbol	Dimensions in Millimeters		
	Min.	Nom.	Max.
A	0.70	0.75	0.80
A1	0	0.02	0.05
A2	---	0.55	---
A3	0.203 REF		
b	0.15	0.2	0.25
b1	0.2	0.25	0.3
b2	0.25	0.3	0.35
D	2 BSC		
E	3 BSC		
e	0.45 BSC		
e1	0.475 BSC		
e2	0.575 BSC		
e3	0.1 BSC		
L	0.35	0.40	0.45
L1	0.55	0.6	0.65
L2	1.475	1.525	1.575
L3	0.15 REF		
aaa	0.1		
ccc	0.1		
eee	0.05		
bbb	0.1		

NOTE:

1. Drawing proposed to be made a JEDEC package outline MO-220 variation.
2. Drawing not to scale.
3. All linear dimensions are in millimeters.
4. Contact PCB board fabrication for minimum solder mask web tolerances between the pins.

TAPE AND REEL INFORMATION

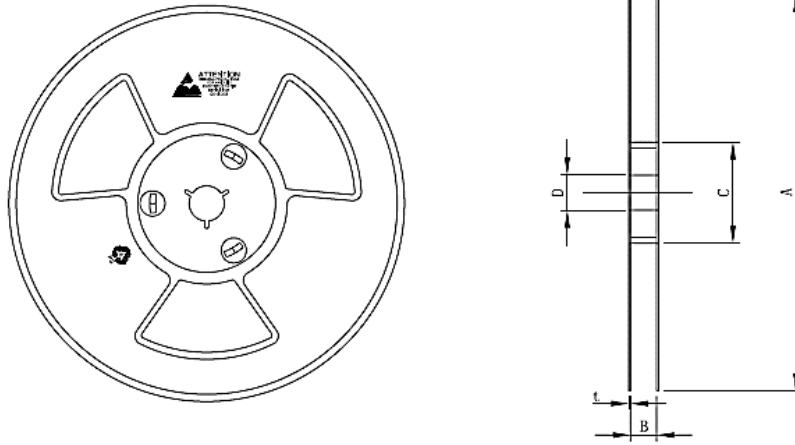

SYMBOL	MILLIMETER		
	MIN	NOM	MAX
A	328	329	330
B	11.80	12.80	13.80
C	99	100	101
D	13.00	13.30	13.60
t	1.70	2.00	2.30

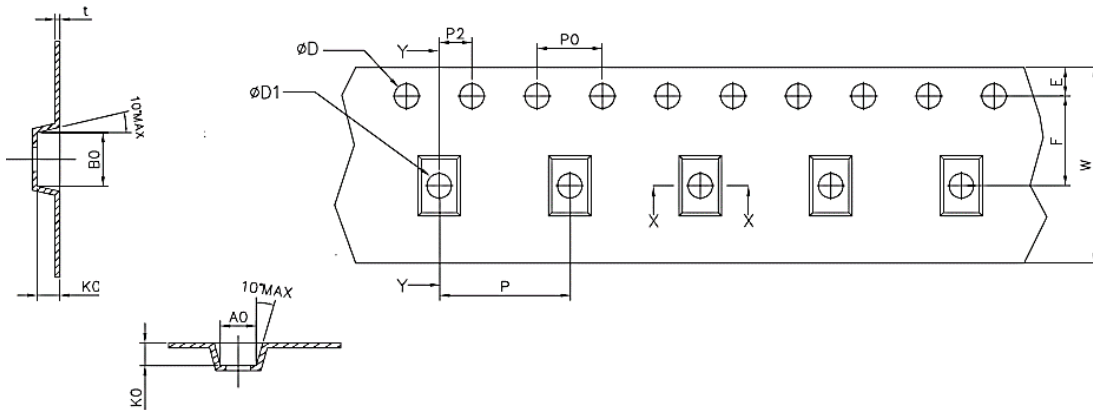

SYMBOL	MILLIMETER		
	MIN	NOM	MAX
E	1.65	1.75	1.85
F	5.45	5.50	5.55
P2	1.95	2.00	2.05
D		1.50	1.60
D1		1.50	1.75
P0	3.90	4.00	4.10
W	11.90	12.00	12.30
P	7.90	8.00	8.10
A0	2.10	2.20	2.30
B0	3.20	3.30	3.40
K0	1.04	1.14	1.24
t	0.23	0.25	0.27