

3V-28V Vin, 300mA, 2.4uA Iq, Low-Dropout Regulator with PG Feature

FEATURES

- Wide Input Range: 3V-28V
- With up to 32V Transient Input Voltage
- Maximum Output Current: 300mA
- Output Voltage:
 - 3.3V and 5V (Fixed Output)
 - 1.2V, 1.8V, 2.5V, 3V, 4.2V and 4.5V (Need contact SCT sales)
- Output Voltage Accuracy:
 - T=25°C : ±1%
 - T= -40°C~ 125°C : ±2%
- Low Quiescent Current: 2.4uA
- Low Dropout Voltage :
 - 230mV at 100mA load current
 - 470mV at 200mA load current
- Support Output Capacitors Range:
 - 3.3uF~220uF
 - Low-ESR: 0.001Ω~ 5 Ω
- 550us Internal Soft-start Time
- Integrated Short-Circuit Protection
- Precision Enable Threshold for Programmable Input Voltage Under-Voltage Lock Out Protection (UVLO) Threshold and Hysteresis
- Power-Good Feature is available
- Over-Temperature Protection
- Available Package: SOT23-5L

APPLICATIONS

- Handheld Devices with Battery Power
- Industrial control
- Smoke and heat detectors
- Electricity meter

DESCRIPTION

The SCT71203 series products is a low-dropout linear regulator designed to operate with a wide input-voltage range from 3 V to 28 V (32V transient input voltage) and 300mA output current with enable control and Power-Good feature. The SCT71203 series products is stable with 3.3uF~220uF output capacitors, and 10uF ceramic capacitor is recommended.

Only 2.4-μA typical quiescent current at light load makes the SCT71203 series products ideal choices for portable devices with battery power supply and an optimal solution for powering microcontrollers (MCUs) and CAN/LIN transceivers in always-on systems.

The SCT71203 series products implements power good circuit (PG) which indicates that output voltage is in regulation. This signal could be used for power sequencing or as a microcontroller reset.

The SCT71203 series products integrated short-circuit and overcurrent protection, which makes the device more reliable during transient high-load current faults or shorting events.

The SCT71203 series products provide fixed 3.3V and 5V output voltage versions, and also could provide 1.2V, 1.8V, 2.5V, 3V, 4.2V and 4.5V fixed output voltage versions, please contact SCT sales if needed.

The SCT71203 series products is available in SOT23-5L package, for other package options, please contact SCT sales.

TYPICAL APPLICATION

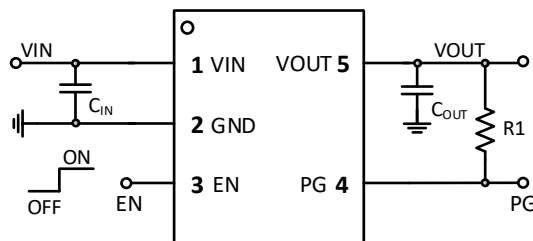

SCT71203 Series

REVISION HISTORY

NOTE: Page numbers for previous revisions may differ from page numbers in the current version.

Revision 1.0: Release to production.

Revision 1.1: Update Part Number.

Revision 1.2: Update DEVICE ORDER INFORMATION and TAPE AND REEL INFORMATION.

Revision 1.3: Update MSL level and add test condition for Load regulation.

Revision 1.4: Update Load regulation.

Revision 1.5: Update Line regulation.

DEVICE ORDER INFORMATION

Orderable Device	Output Voltage	Package	Package Marking	PINS	MSL	Transport Media, Quantity
SCT71203F50TWDR	Fixed 5.0V	SOT23-5L	3F50	5	3	Tape & Reel, 3000
SCT71203F33TWDR	Fixed 3.3V	SOT23-5L	3F33	5	3	Tape & Reel, 3000

PIN CONFIGURATION

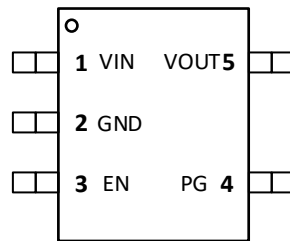

SCT71203FxxTWDR

SOT23-5L Package

PIN FUNCTIONS

NAME	PIN FUNCTION	
	SOT23-5L	
VIN	1	Input voltage pin
GND	2	Ground reference pin.
EN	3	Enable input pin
PG	4	Power-good pin
VOUT	5	Regulated output voltage pin

RECOMMENDED OPERATING CONDITIONS

Over operating free-air temperature range unless otherwise noted

PARAMETER	DEFINITION	MIN	MAX	UNIT
V _{IN}	Input voltage range	3	28	V
V _{OUT}	Output voltage range	1.2	5	V
V _{EN}	Enable input voltage	0	V _{IN}	V
V _{PG}	Power-good pin voltage	0	5	V
C _{IN}	Input capacitor	2.2	--	uF
C _{OUT}	Output capacitor	3.3	220	uF
ESR	Output capacitor ESR requirements	0.001	5	Ω
T _A	Operating ambient temperature	-40	125	°C
T _J	Operating junction temperature	-40	150	°C

ABSOLUTE MAXIMUM RATINGS

Over operating free-air temperature range unless otherwise noted ⁽¹⁾

PARAMETER	DEFINITION	MIN	MAX	UNIT
V _{IN}	Maximum input voltage range	-0.3	32	V
V _{OUT}	Maximum output voltage range	-0.3	5.5	V
V _{EN}	Maximum enable input voltage	-0.3	V _{IN}	V
V _{PG}	Maximum power-good pin voltage	-0.3	5.5	V
T _J ⁽²⁾	Junction temperature range	-40	150	°C
T _{stg}	Storage temperature range	-65	150	°C

- (1) Stresses beyond those listed under Absolute Maximum Rating may cause device permanent damage. The device is not guaranteed to function outside of its Recommended Operation Conditions.
- (2) The IC includes over temperature protection to protect the device during overload conditions. Junction temperature will exceed 150°C when over temperature protection is active. Continuous operation above the specified maximum operating junction temperature will reduce lifetime.

ESD RATINGS

PARAMETER	DEFINITION	MIN	MAX	UNIT
V _{ESD}	Human Body Model(HBM), per ANSI-JEDEC-JS-001-2014 specification, all pins ⁽¹⁾	-3	+3	kV
	Charged Device Model(CDM), per ANSI-JEDEC-JS-002-2014 specification, all pins ⁽²⁾	-1	+1	kV

- (1) JEDEC document JEP155 states that 500V HBM allows safe manufacturing with a standard ESD control process.
- (2) JEDEC document JEP157 states that 250V CDM allows safe manufacturing with a standard ESD control process.

SCT71203 Series

THERMAL INFORMATION

The value of $R_{\theta JA}$ and $R_{\theta JC}$ given in this table is only valid for comparison with other packages and cannot be used for design purposes. Because they were simulated in accordance with JESD 51-7. They do not represent the performance obtained in an actual application. For design information see Power Dissipation and Thermal Performance section.

The value of $R_{\theta JA_EVM}$ is the tested results based on our EVM, and is more useful for thermal design. Even if it still do not represent the thermal performance of customer's PCB design, but it was a good starting point for thermal performance design.

The PCB information of our EVM: 2-layer, 1 oz Cu, 50mm x 30mm size.

The values given in this table are not a characteristic of package itself, but of many other system level characteristics such as the design and layout of the printed circuit board (PCB), thermal pad size, and external environmental factors. The PCB board is a heat sink that is soldered to the leads and thermal pad of the device. Changing the design or configuration of the PCB board changes the efficiency of the heat sink and therefore the actual values of the below table.

Package Type	$R_{\theta JA}^{(1)}$	$R_{\theta JC}^{(2)}$	$R_{\theta JA_EVM}^{(3)}$	UNIT
SOT23-5L	161.1	/	115.4	°C/W

- (1) $R_{\theta JA}$ is junction to ambient thermal resistance, based on JESD51-7.
- (2) $R_{\theta JC}$ is junction to case thermal resistance, based on JESD51-7.
- (3) $R_{\theta JA_EVM}$ is junction to ambient thermal resistance, which is tested on SCT EVM.

ELECTRICAL CHARACTERISTICS

$V_{IN}=V_{OUT}+1V$, $C_{OUT}=10\mu F$, $T_J=-40^{\circ}C\sim 125^{\circ}C$, typical value is tested under $25^{\circ}C$.

SYMBOL	PARAMETER	TEST CONDITION	MIN	TYP	MAX	UNIT
Power Supply						
V_{IN}	Operating input voltage		3		28	V
V_{UVLO}	V_{IN} UVLO Threshold Hysteresis	V_{IN} rising	2.3	2.66 180	2.9	V mV
I_{SHDN}	Shutdown current from V_{IN} pin	$EN=0$, $V_{OUT}=3.3V$, $V_{IN}=4.3V$		0.25		μA
		$EN=0$, $V_{OUT}=5V$, $V_{IN}=6V$		0.4		μA
		$EN=0$, $V_{OUT}=3.3V/5V$, $V_{IN}=12V$		0.6		μA
I_Q	Quiescent current from GND pin	EN float, no load, $V_{IN}=V_{OUT}+1V$		2.4		μA
		EN float, no load, $V_{IN}=12V$		2.6		μA
Regulated Output Voltage and Current						
V_{OUT}	Output voltage accuracy	$T_J=25^{\circ}C$	-1%		1%	
		$T_J=-40^{\circ}C\sim 125^{\circ}C$	-2%		2%	
ΔV_{OUT}	Line regulation	$V_{IN}=V_{OUT}+1V$ to 28V, or $V_{IN}>3V$, $I_{OUT}=10mA$		1	20	mV
	Load regulation	$I_{OUT}=1mA$ to 300mA		10	50	mV
V_{DROP}	Dropout voltage ⁽¹⁾	$V_{IN}=V_{OUT}-0.1V$, $I_{OUT}=100mA$		230		mV
		$V_{IN}=V_{OUT}-0.1V$, $I_{OUT}=200mA$		470		mV
		$V_{IN}=V_{OUT}-0.1V$, $I_{OUT}=300mA$		730		mV
I_{OUT}	Output current	V_{OUT} in regulation	0		300	mA
I_{OC}	Output current limit	$V_{OUT}=0V$		500		mA
PSRR	Power supply rejection ratio ⁽²⁾	$I_{OUT}=10mA$, $f=1kHz$, $C_{OUT}=10\mu F$		75		dB
		$I_{OUT}=10mA$, $f=10kHz$, $C_{OUT}=10\mu F$		50		dB
		$I_{OUT}=10mA$, $f=100kHz$, $C_{OUT}=10\mu F$		45		dB
Enable and Soft-startup						
V_{EN_H}	Enable high threshold			1.23		V
V_{EN_L}	Enable low threshold			1.02		V
V_{EN_Hys}	Enable threshold hysteresis			210		mV
I_{EN_OV}	Enable pin pull-up current	$EN=0V$		0.35		μA
T_{SS}	Soft-start time			550		μs
Power Good						
V_{PG_R}	PG rising threshold percentage	$V_{OUT}/V_{OUT(NOM)}$, when V_{OUT} rising		91%		
V_{PG_F}	PG falling threshold percentage	$V_{OUT}/V_{OUT(NOM)}$, when V_{OUT} falling		85%		
V_{PG_LOW}	PG output low voltage	$V_{OUT}=0.8 \times V_{OUT(NOM)}$, PG sink 500 μA		44		mV
R_{PG}	PG pull down resistor	$R_{PG}=V_{PG_LOW}/0.5mA$		88		Ω
I_{PG_LKG}	PG leakage current	PG=5V, V_{OUT} in regulation		20		nA
Td_{PGR}	PG signal turn to high delay	From $V_{OUT}>0.91 \times V_{OUT(NOM)}$ to PG rising edge delay time		130		μs
Td_{PGF}	PG signal turn to low delay	From $V_{OUT}<0.85 \times V_{OUT(NOM)}$ to PG falling edge delay time		12		μs

SCT71203 Series

Thermal Protection

T _{SD}	Thermal shutdown threshold ⁽³⁾	T _J rising Hysteresis	170 15	°C °C
-----------------	---	-------------------------------------	-----------	----------

- (1) The dropout voltage is defined as $V_{IN}-V_{OUT}$, when force V_{IN} is 100mV below the value of V_{OUT} for $V_{IN}=V_{OUT(NOM)}+1V$.
- (2) PSRR is derived from bench characterization, not production test.
- (3) Thermal shutdown threshold is derived from bench characterization, not production test.

TYPICAL CHARACTERISTICS

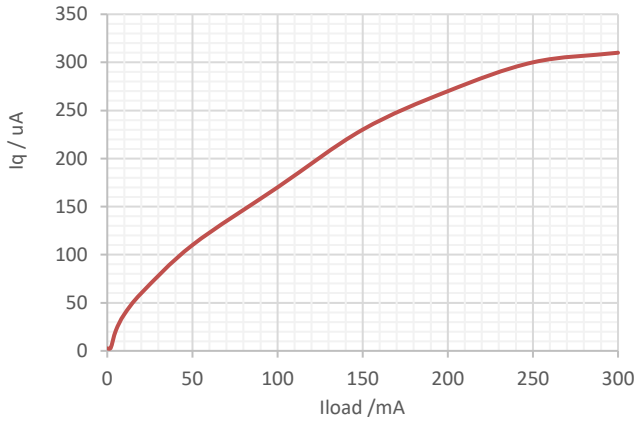

Figure 1. Quiescent Current vs Output Current

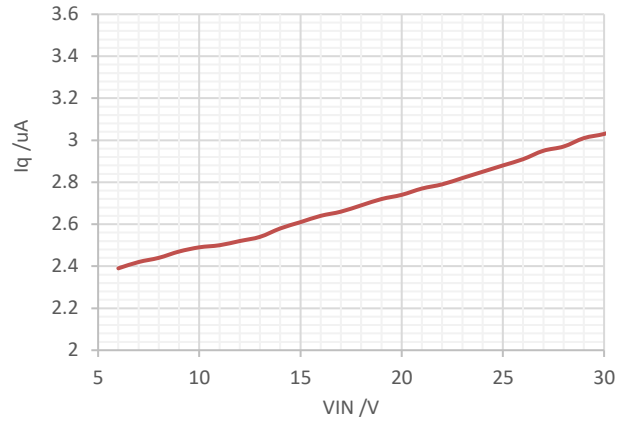

Figure 2. Quiescent Current vs Input Voltage

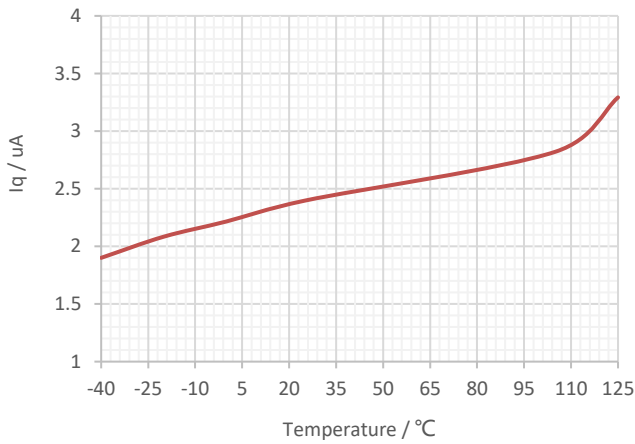

Figure 3. Quiescent Current vs Ambient Temperature

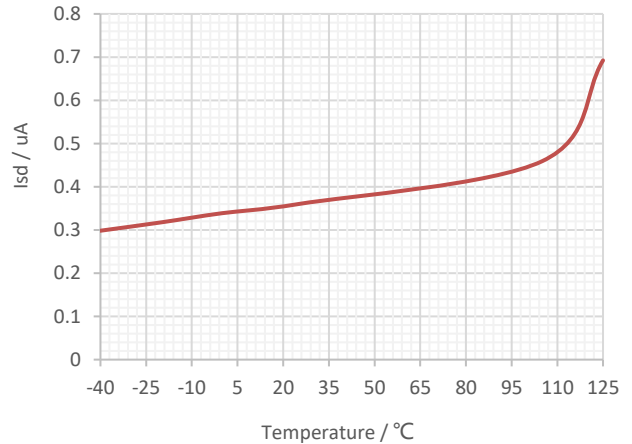

Figure 4. Shutdown Current vs Ambient Temperature

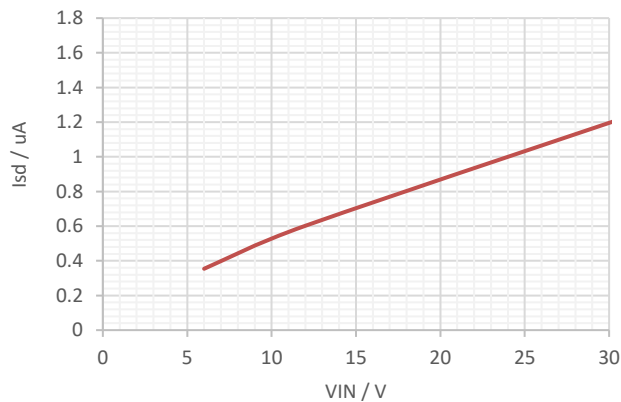

Figure 5. Shutdown Current vs Input Voltage

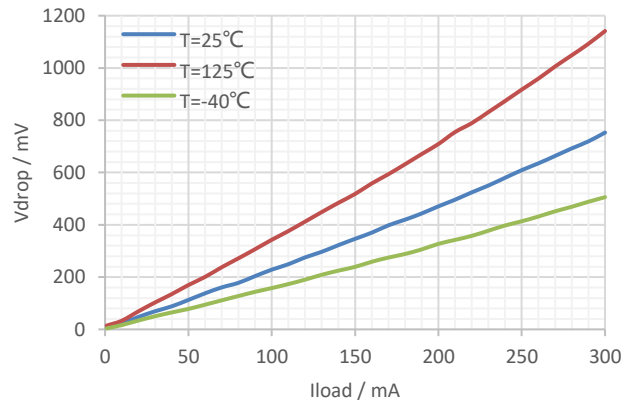

Figure 6. Dropout Voltage vs Output Current

TYPICAL CHARACTERISTICS (continued)

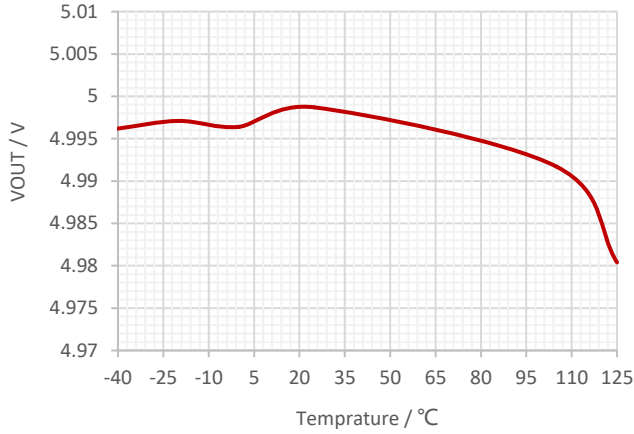

Figure 7. Output Voltage vs Ambient Temperature at VOUT=5V

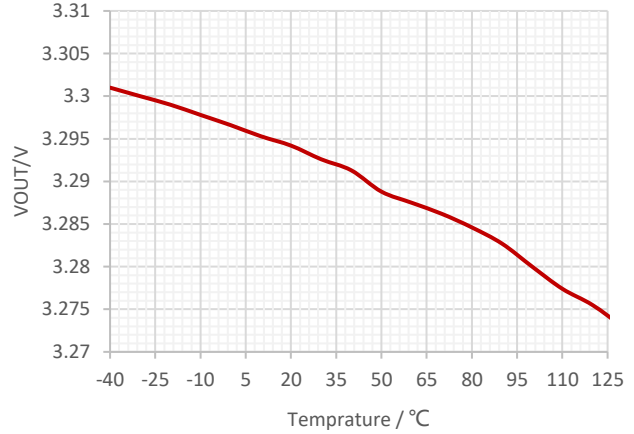

Figure 8. Output Voltage vs Ambient Temperature at VOUT=3.3V

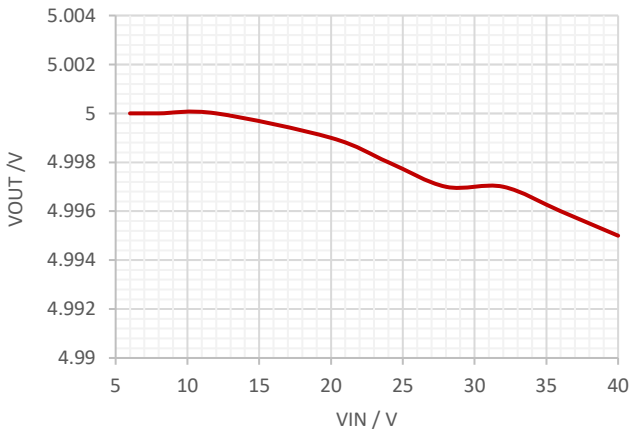

Figure 9. Output Voltage vs Input Voltage

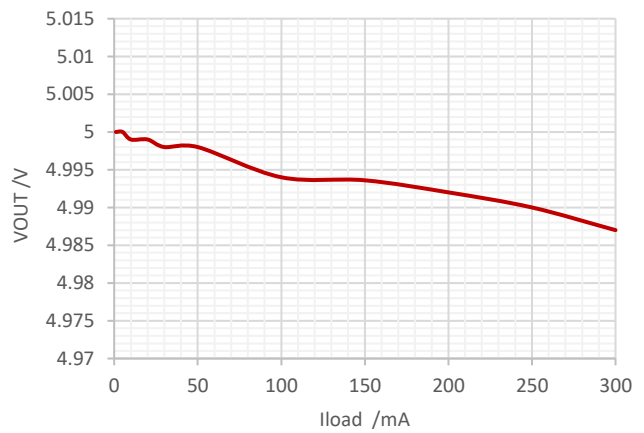

Figure 10. Output Voltage vs Output Current

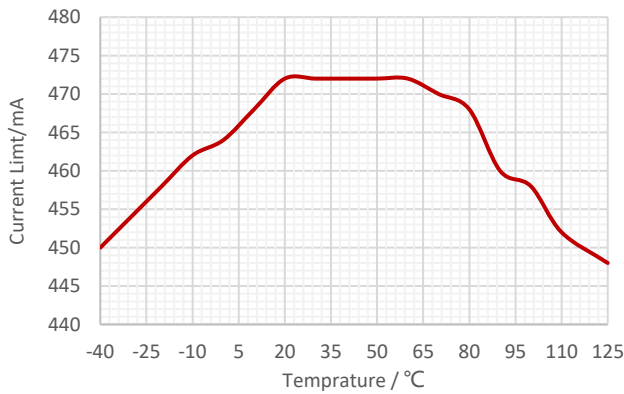

Figure 11. Output Current Limit vs Ambient Temperature

TYPICAL CHARACTERISTICS (continued)

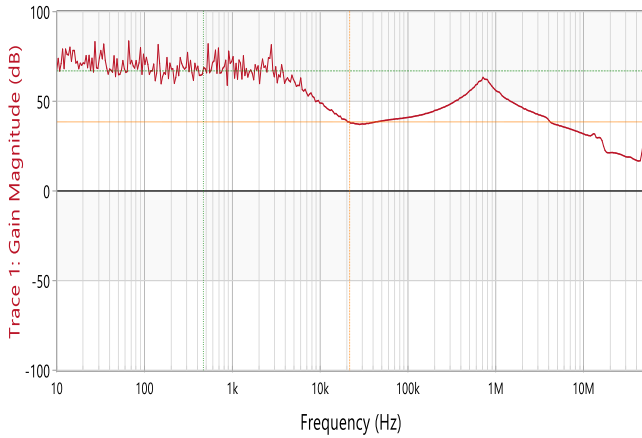

Figure 12. PSRR vs Frequency at $I_{out}=10\text{mA}$, $C_{OUT}=4.7\mu\text{F}$

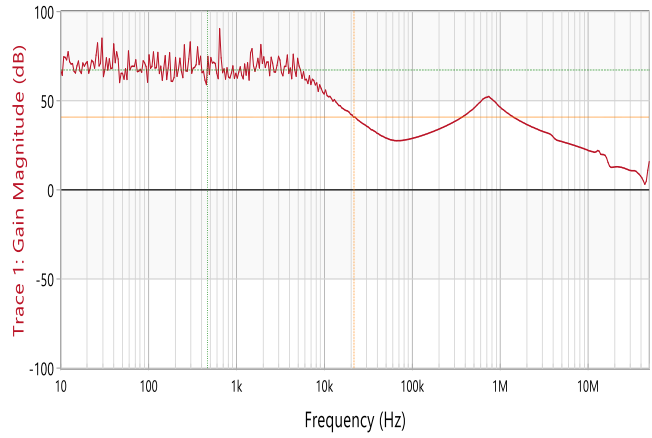

Figure 13. PSRR vs Frequency at $I_{out}=100\text{mA}$, $C_{OUT}=4.7\mu\text{F}$

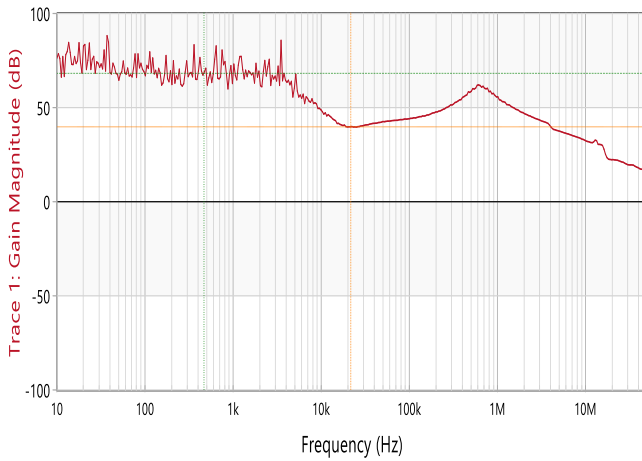

Figure 14. PSRR vs Frequency at $I_{out}=10\text{mA}$, $C_{OUT}=10\mu\text{F}$

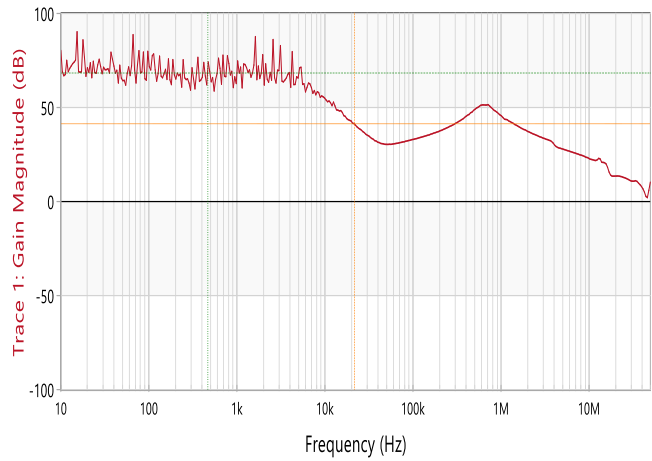

Figure 15. PSRR vs Frequency at $I_{out}=100\text{mA}$, $C_{OUT}=10\mu\text{F}$

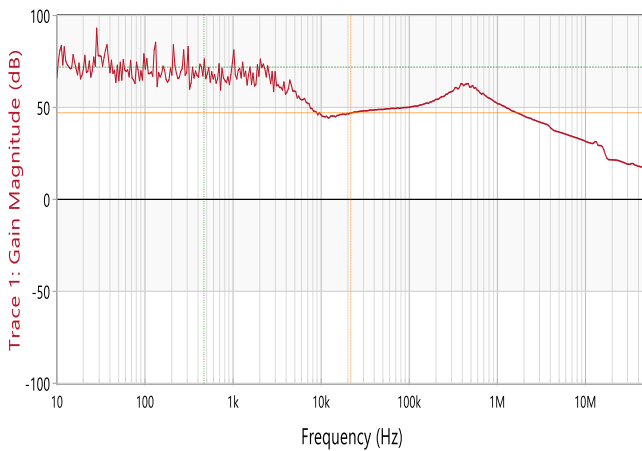

Figure 16. PSRR vs Frequency at $I_{out}=10\text{mA}$, $C_{OUT}=22\mu\text{F}$

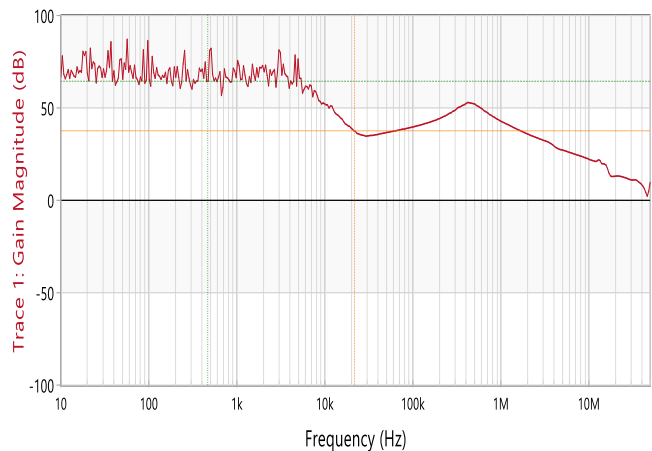

Figure 17. PSRR vs Frequency at $I_{out}=100\text{mA}$, $C_{OUT}=22\mu\text{F}$

FUNCTIONAL BLOCK DIAGRAM

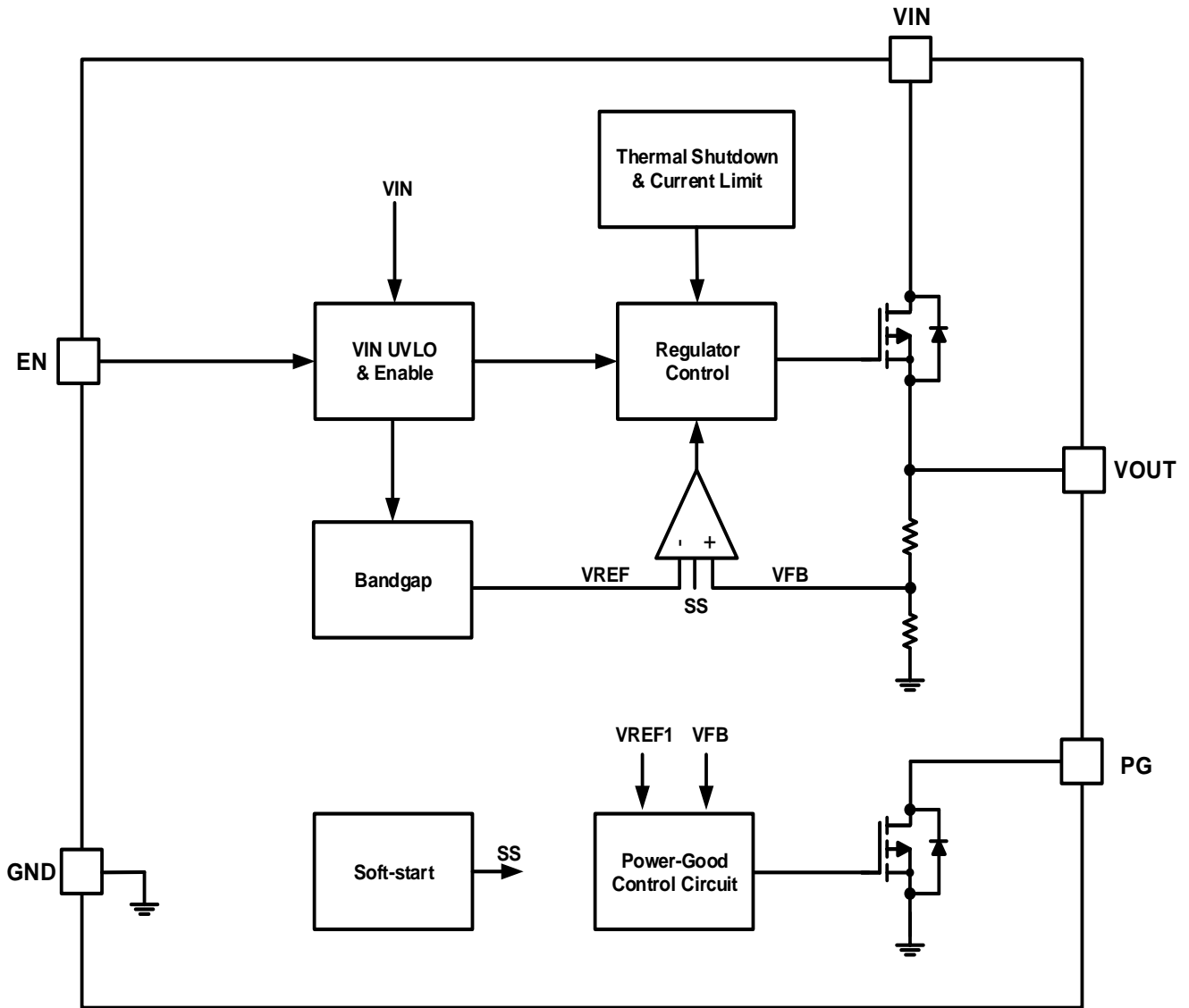

Figure 18. Functional Block Diagram

OPERATION

Overview

The SCT71203 series products are 300mA wide input voltage range linear regulators with very low quiescent current. These voltage regulators operate from 3V to 28V DC input voltage with supporting 32V transient input voltage and consume 2.4µA quiescent current at no load.

The SCT71203 series products is stable with 3.3µF~220µF output capacitors, and 10µF ceramic capacitor is recommended. An internal 550us soft-start time avoids large inrush current and output voltage overshoot during startup.

The SCT71203 series products also provide enable control and Power-Good feature, which is very suitable for the applications needing sequence configuration. Other protection features include the VIN input under-voltage lockout, over current protection, output hard short protection and thermal shutdown protection.

The SCT71203 series products are available in fixed voltage versions of 3.3V and 5V with 1% output voltage accuracy at room temperature and 2% output voltage accuracy over operating conditions. The series products are available in SOT23-5L packages.

The SCT71203 series products also could provide other fixed output voltage versions of 1.2V, 1.8V, 2.5V, 3V, 4.2V and 4.5V and other package options of SOT23-3, TO252-5 etc. Please feel free to contact SCT sales, if you need a new output voltage version or a new package option.

Enable and Under Voltage Lockout Threshold

The SCT71203 series products is enabled when the VIN pin voltage rises above 3V and the EN pin voltage exceeds the enable threshold V_{EN_H} . The device is disabled when the VIN pin voltage falls below 2.48V or when the EN pin voltage is below V_{EN_L} . Internal pull up current source to EN pin allows the device enable when EN pin floats.

For a higher system UVLO threshold, connect an external resistor divider (R1 and R2) from VIN to GND shown in Figure 19. The UVLO rising and falling threshold can be calculated by Equation 1 and Equation 2 respectively.

$$VIN_{rise} = V_{EN_H} * \frac{R1 + R2}{R2} \quad (1)$$

$$VIN_{hys} = (V_{EN_H} - V_{EN_L}) * \frac{R1 + R2}{R2} \quad (2)$$

Where

VIN_{rise} : Vin rise threshold to enable the device

VIN_{hys} : Vin hysteresis threshold

$I_1=0.34\mu A$ and could be neglected in the calculation

$V_{EN_H}=1.23V$

$V_{EN_L}=1.02V$

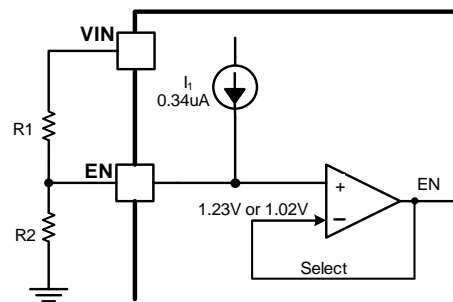

Figure 19. System UVLO by enable divide

Regulated Output Voltage

The SCT71203 series are available in fixed voltage versions of 3.3V and 5V. When the input voltage is higher than $V_{OUT(NOM)}+V_{DROPO}$, output pin is the regulated output based on the selected voltage version. When the input voltage falls below $V_{OUT(NOM)}+V_{DROPO}$, output pin tracks the input voltage minus the dropout voltage based on the load current. When the input voltage drops below UVLO threshold, the output keeps shut off.

The SCT71203 series products also could provide other fixed output voltage versions of 1.2V, 1.8V, 2.5V, 3V, 4.2V and 4.5V and other package options of SOT23-3, TO252-5 etc. Please feel free to contact SCT sales, if you need a new output voltage version or a new package option.

SCT71203 Series

Over Current Limit

The SCT71203 series products has an internal current limit circuit that protects the regulator during transient high-load current faults or shorting events. In a high-load current fault, the brick-wall current limit scheme limits the output current to the current limit (I_{OC}).

The output voltage is not regulated when the device is in current limit. When a current limit event occurs, the regulator begins to heat up because of the increase in power dissipation. When the device is in brick-wall current limit, the pass transistor dissipates power $[(V_{IN}-V_{OUT}) \times I_{OC}]$. If thermal shutdown is triggered, the device turns off. After the device cools down, the internal thermal shutdown circuit turns the device back on. If the output current fault condition persists, the device cycles between current limit and thermal shutdown.

The characteristic is shown in the following figure.

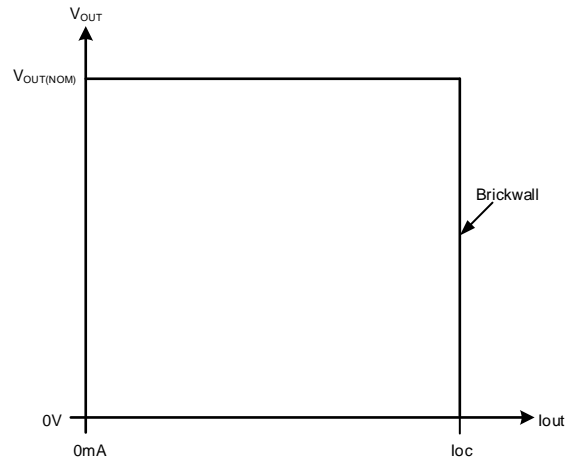

Figure 20. Current Limit Feature

Internal Soft-Start

The SCT71203 series products integrates an internal soft-start circuit that ramps the reference voltage from zero volts to 0.6V reference voltage in 550 μs . If the EN pin is pulled below 1.02V, LDO will be shut off and the internal soft-start resets. The soft-start also resets during shutdown due to thermal overloading.

Below figure shows the startup waveform at small output capacitor and large output capacitor. When output capacitor is small, for example 10 μF , the slope of V_{OUT} is limit by soft-start. When output capacitor is large, for example 100 μF , the slope of V_{OUT} is limited by over current limit (I_{OC}).

In SCT71203, typical T_{SS} is 550 μs , and typical I_{OC} is 500mA, could use the following formula for initial startup time calculation.

$$T_{start} = \max\left(\frac{C_{OUT} \times V_{OUT}}{(I_{OC} - I_{load})}, T_{SS}\right) \quad (3)$$

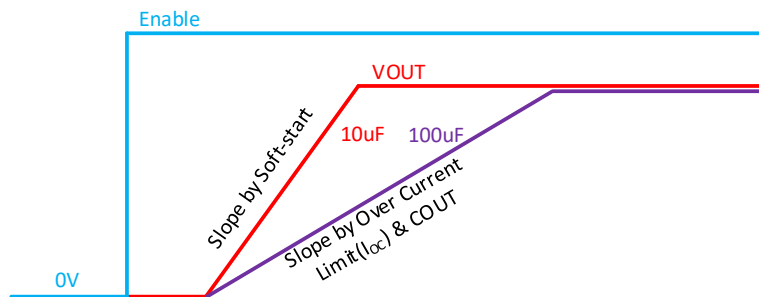

Figure 21. Soft-start Waveform vs Output Capacitor

Power-Good and Power-Good Delay

The power-good (PG) pin is an open-drain output and can be connected to any 5V or lower rail through an external pull-up resistor. And it also could be allowed to connect to power rail higher than 5V, because of integrating a zener diode from PG pin to GND internally, and in this condition, the maximum high level voltage of PG will be clamped as the breakdown voltage of zener diode, which is 5.6V typically. The PG output is high-impedance when V_{OUT} is greater than the PG trip threshold ($V_{PG_R}=91\% \times V_{OUT(NOM)}$). If V_{OUT} drops below $V_{PG_F}=85\% \times V_{OUT(NOM)}$, the open-drain output turns on and pulls the PG output low. If output voltage monitoring is not needed, the PG pin can be left floating or connected to GND.

The power-good delay time (T_{d_PGR}) is defined as the time period from when V_{OUT} exceeds the PG trip threshold voltage (V_{PG_R}) to when the PG output is high. This power-good delay time is set by an internal time, which is 130us typical. The power-good deglitch time (T_{d_PGF}) is defined as the time period from when V_{OUT} fall below the PG trip threshold voltage (V_{PG_F}) to when the PG output is low. This power-good deglitch time is set by an internal time, which is 12us typical. If the power-good delay time is not enough for some application, could try to connect a capacitor from PG pin to GND and using PG pull-up resistor and this capacitor generate extra delay time to meet your design.

To ensure proper operation of the power-good feature, maintain $V_{IN} \geq 3V$ (V_{IN_MIN}). It allows connections of PG pin to circuit with the same or different power supply voltage to the LDO's V_{OUT} level. Below are the connections examples.

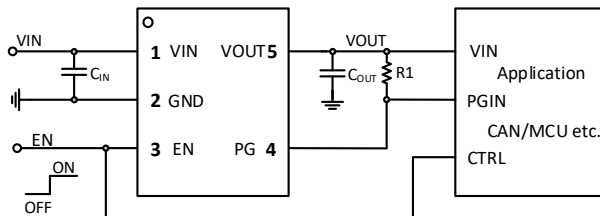

Figure 22. PG Connected to LDO's Output

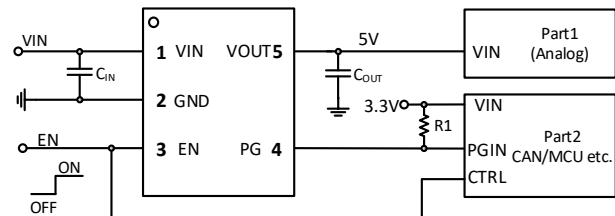

Figure 23. PG Connected to the other Power Supply

Below figure shows the startup and shutdown situation when slow power up and power down.

At the point 0, the input voltage starts to rise from 0 to 6 V, LDO is in shutdown (because V_{IN} is below its UVLO threshold) and output voltage is 0V.

At the point 1, the V_{IN} voltage reaches UVLO threshold level and LDO starts charging of output capacitor. V_{OUT} rising speed is defined by internal soft-start function.

At the point 2, the V_{OUT} voltage reaches almost the V_{IN} voltage as it rises faster and LDO gets into dropout region. The difference between V_{IN} and V_{OUT} is the dropout voltage.

At the point 3, the V_{OUT} reaches PG threshold ($V_{PG_R}=91\% \times V_{OUT(NOM)}$) and from this point LDO counts the power good delay time (T_{d_PGR}). After this delay, the PG pin rises to high level showing that V_{OUT} is ok.

At the point 4, the V_{OUT} reaches its nominal value (5.0V) as the V_{IN} starts to be higher than ($V_{OUT(NOM)} + V_{DROP}$) and LDO gets into regulation region.

At the point 5, as the V_{IN} voltage slow power down and LDO returns to dropout region again.

At the point 6, the V_{OUT} drops below PG threshold ($V_{PG_F}=85\% \times V_{OUT(NOM)}$) and LDO starts counting the power good deglitch time (T_{d_PGF}), which filters fast V_{OUT} undershoots (caused for example by line/load transient responses) After this delay, the PG output is shorted to 0 V level to highlight "power fail" state.

At the point 7, the V_{IN} voltage is lower than input voltage UVLO threshold minus UVLO hysteresis level and LDO goes into the shutdown state.

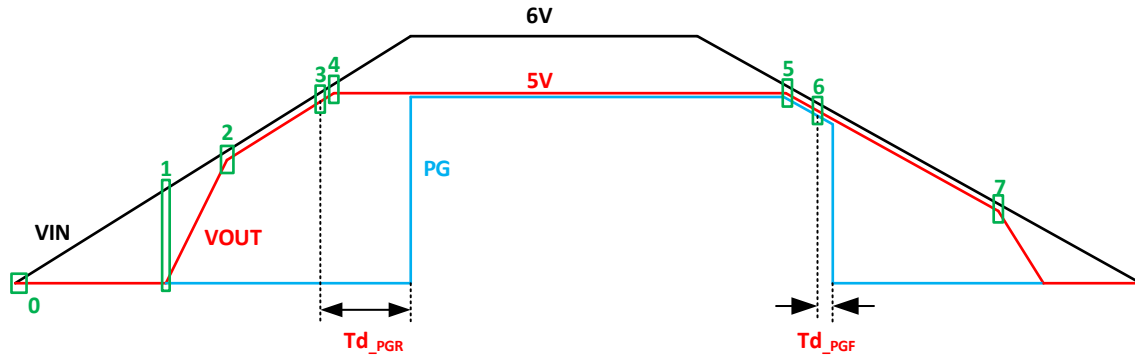

Figure 24. Startup and Shutdown Example —SCT71203 Series

Thermal Shutdown

This device incorporates a thermal shutdown (T_{SD}) circuit as a protection from overheating. For continuous normal operation, the junction temperature should not exceed the T_{SD} trip point. The junction temperature exceeding the T_{SD} trip point causes the output to turn off. When the junction temperature falls below the T_{SD} trip point minus thermal shutdown hysteresis, the output turns on again.

APPLICATION INFORMATION

Typical application 1:

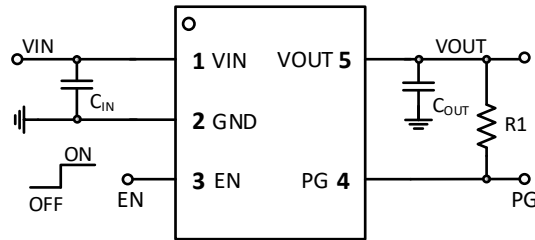

Figure 25. SCT71203 Typical Application Schematic

Design Parameters

Design Parameters	Example Value
Input Voltage	12V Normal, 3V~28V
Output Voltage	5V or 3.3V
Maximum Output Current	300mA
Output Capacitor Range (C_{OUT})	3.3uF~22uF , recommends 10uF
Input Capacitor Range (C_{IN})	>2.2uF , recommends 10uF
Pull-up resistor of power-good (R1)	>10kΩ

Typical application 2:

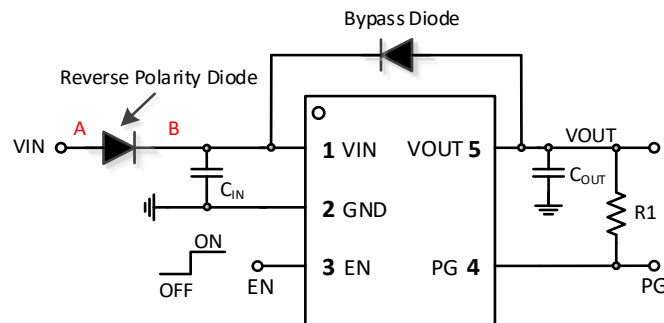

Figure 26. SCT71203 Typical Application Schematic with Reverse Polarity Diode

Design Parameters

Design Parameters	Example Value
Input Voltage	12V Normal, 3V~28V
Output Voltage	5V or 3.3V
Maximum Output Current	300mA
Output Capacitor Range (C_{OUT})	3.3uF~22uF , recommends 10uF
Input Capacitor Range (C_{IN})	>2.2uF , recommends 10uF
Pull-up resistor of power-good (R1)	>10kΩ

SCT71203 Series

In some applications, the VIN and the VOUT potential might be reversed, possibly resulting in circuit internal damage or damage to the elements. For example, the accumulated charge in the output pin capacitor flowing backward from the VOUT to the VIN when the VIN shorts to the GND. In order to minimize the damage in such case, use a capacitor with a capacitance less than 220 μ F. Also by inserting a reverse polarity diode in series to the VIN, it can prevent reverse current from reverse battery connection or the case, when the point A is short-circuited GND. If there may be any possible case point B is short-circuited to GND, we also recommend using a bypass diode between the VIN and the VOUT.

Typical application 3:

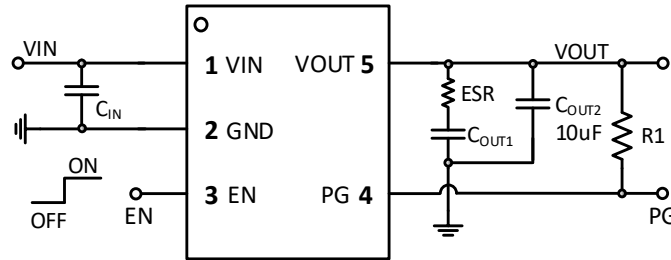

Figure 27. SCT71203 Typical Application Schematic with Large Output Capacitor

Design Parameters

Design Parameters	Example Value
Input Voltage	12V Normal, 3V~28V
Output Voltage	5V or 3.3V
Maximum Output Current	300mA
Output Capacitor Range (C_{OUT1} and ESR)	3.3 μ F~220 μ F with ESR=0.5 Ω ~5 Ω
Output Capacitor Range (C_{OUT2})	recommends 10 μ F with low ESR
Input Capacitor Range (C_{IN})	>2.2 μ F , recommends 10 μ F
Pull-up resistor of power-good (R1)	>10k Ω

Input Capacitor and Output Capacitor

SCT recommends adding a 2.2 μ F or greater capacitor with a 0.1 μ F bypass capacitor in parallel at VIN pin to keep the input voltage stable. Aluminum electrolytic capacitor or other capacitor with high capacitance is suggested for the system power with large voltage spike. The voltage rating of the capacitors must be greater than the maximum input voltage

To ensure loop stability, the SCT71203 series products requires an output capacitor with a minimum effective capacitance value of 3.3 μ F. And the series products could support output capacitor range from 3.3 μ F to 220 μ F and with an ESR range between 0.001 Ω and 5 Ω . SCT recommends selecting a X5R- or X7R-type 4.7 μ F~10 μ F ceramic capacitor with low ESR over temperature range to improve the load transient response.

When using large output capacitor with higher ESR resistor, for example 100 μ F output electrolytic capacitor with 1 Ω ESR resistor in the application, SCT recommends adding extra 10 μ F low ESR output capacitor parallel connection with the large electrolytic capacitor, this will eliminate the undershoot/overshoot voltage caused by the large ESR resistor and get better load transient performance.

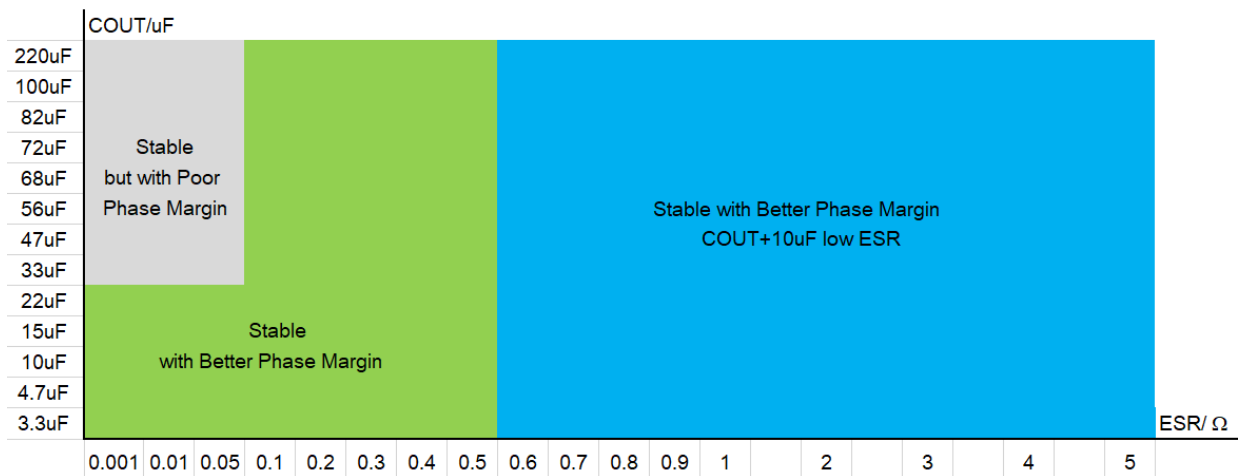

Figure 28. SCT71203 Stability vs Output Capacitor

SCT71203 Series

Power Dissipation and Thermal Performance

Power dissipation caused by voltage drop across the LDO and by the output current flowing through the device needs to be dissipated out from the chip. The maximum junction temperature is dependent on power dissipation, package, the PCB layout, number of used Cu layers, Cu layers thickness and the ambient temperature.

During normal operation, LDO junction temperature should not exceed 150°C, or else it may result in deterioration of the properties of the chip. Using below equations to calculate the power dissipation and estimate the junction temperature.

The power dissipation can be calculated using Equation 4. Because $I_{GND} \ll I_{OUT}$, the term $V_{IN} \times I_{GND}$ in Equation 4 could be ignored.

$$P_D = (V_{IN} - V_{OUT}) \times I_{OUT} + V_{IN} \times I_{GND} \quad (4)$$

The junction temperature can be estimated using Equation 5. $R_{\theta JA_EVM}$ is the junction-to-ambient thermal resistance based on customer's PCB. Verify the application and allow sufficient margins in the thermal design by the following method is used to calculate the junction temperature T_J .

$$T_J = T_A + P_D \times R_{\theta JA_EVM} \quad (5)$$

$R_{\theta JA_EVM}$ is a critical parameter and depends on many factors such as the following:

- Power dissipation
- Air temperature/flow
- PCB area
- Copper heat-sink area
- Number of thermal vias under the package
- Adjacent component placement

For the SCT71203 series products, the maximum power dissipation of SOT23-5L package is about 1.25W based on our EVM test results, larger power dissipation will trigger thermal shutdown protection. As a result, we could calculate the $R_{\theta JA_EVM}$ of SOT23-5L package is 115.4 °C/W. The following figures is just for your reference based on our EVM test, please leave enough margin when you design thermal performance.

The PCB information of our EVM: 2-layer, 1 oz Cu, 50mm x 30mm size.

Thermal Performance of Different Packages Based on EVM Test

Package	Max Allowable PD (W) (Not Trigger TSD)	Max Allowable PD (W) ($T_J \leq 150^\circ\text{C}$)	$R_{\theta JA_EVM}$ (°C/W)
SOT23-5L	1.25	1.08	115.4

THERMAL CHARACTERISTICS

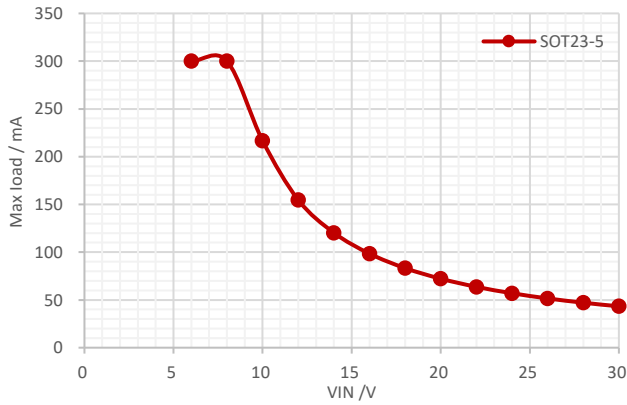

Figure 29. Maximum Output Current vs Input Voltage, VOUT=5V of SOT23-5L, $T_J \leq T_{SD_R}$

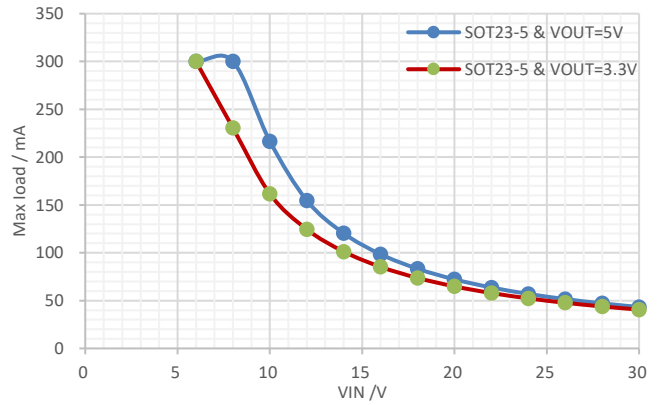

Figure 30. Maximum Output Current vs Input Voltage, SOT23-5L, $T_J \leq 150^\circ\text{C}$

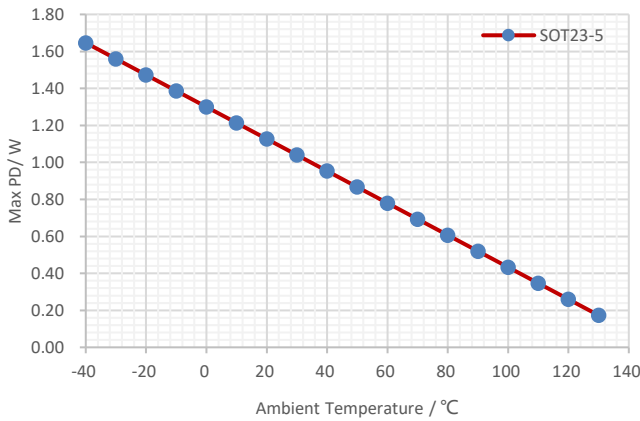

Figure 31. Maximum Allowed Power Dissipation vs Ambient Temperature, SOT23-5L, $T_J \leq 150^\circ\text{C}$

SCT71203 Series

Application Waveforms

Vin=Vout +1V, unless otherwise noted

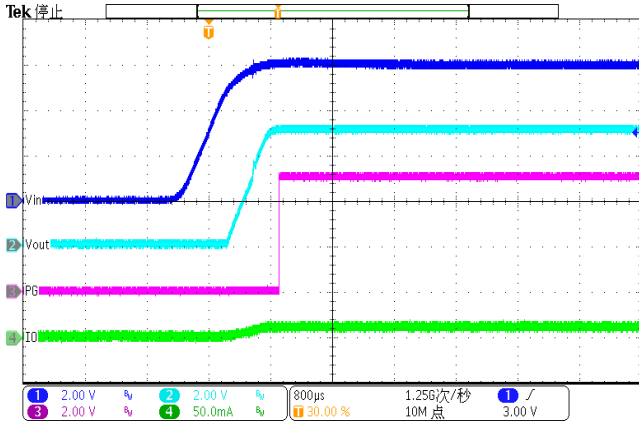

Figure 32. Power up (Iload=10mA)

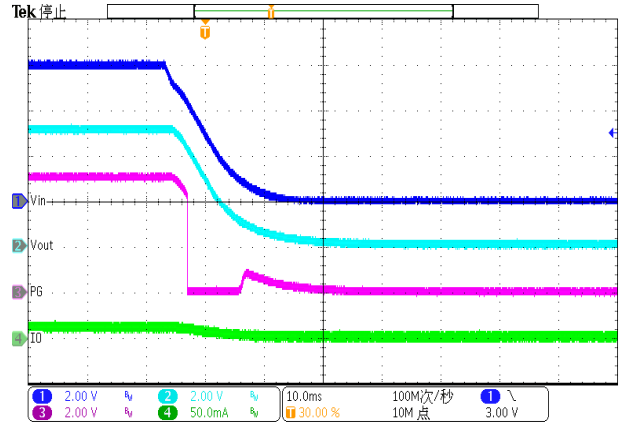

Figure 33. Power down (Iload=10mA)

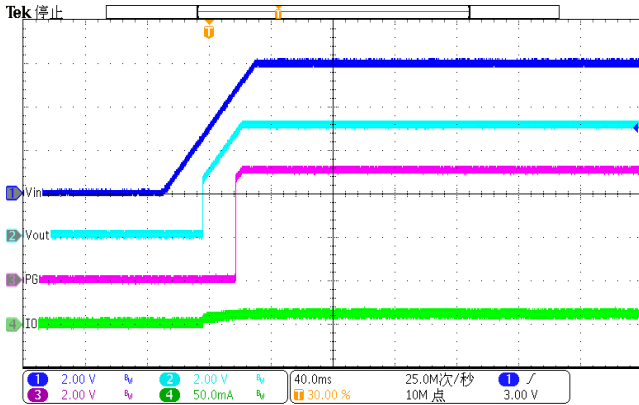

Figure 34 Slow Power up (Iload=10mA)

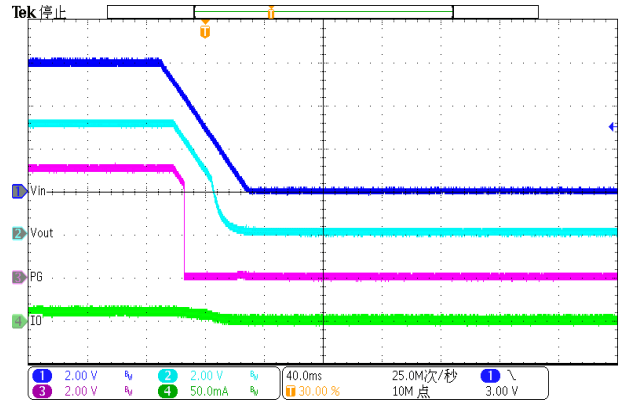

Figure 35. Slow Power down (Iload=10mA)

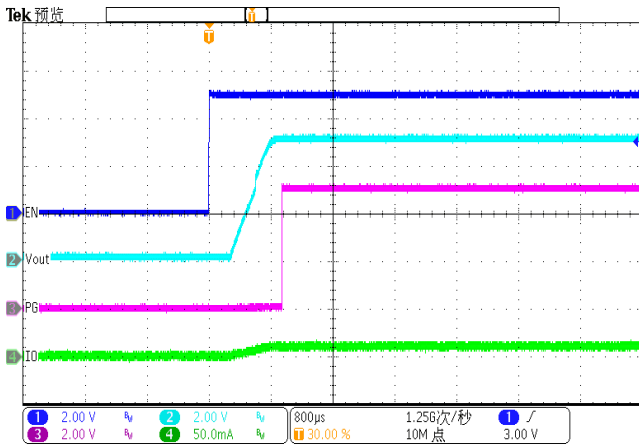

Figure 36. Enable (Iload=10mA)

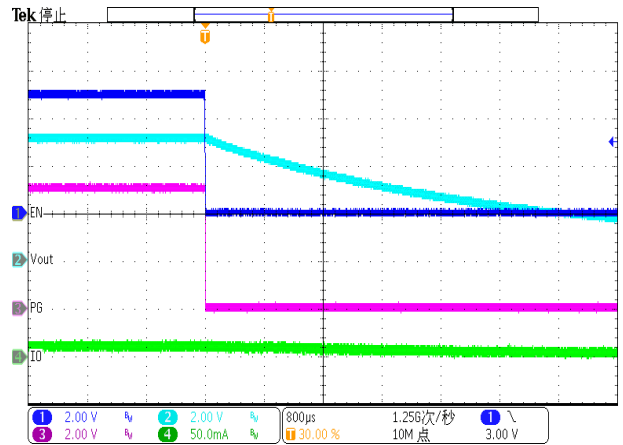

Figure 37. Disable (Iload=10mA)

Application Waveforms(Continued)

$V_{in}=V_{out} + 1V$, unless otherwise noted

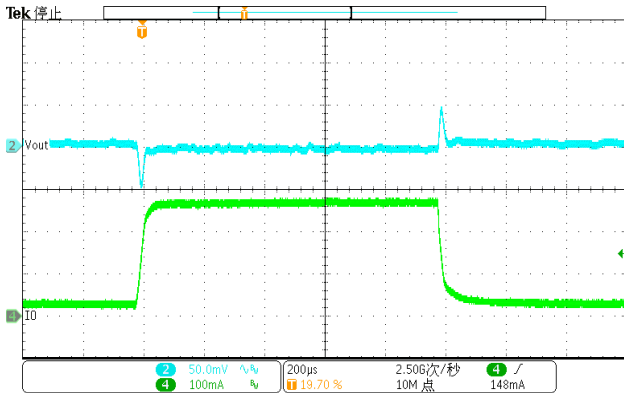

Figure 38. DC-DC Load Transient
(30mA-270mA), $V_{OUT}=5V$

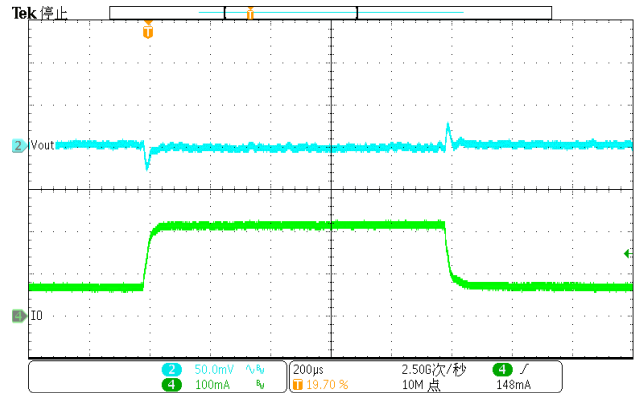

Figure 39. DC-DC Load Transient
(75mA-225mA), $V_{OUT}=5V$

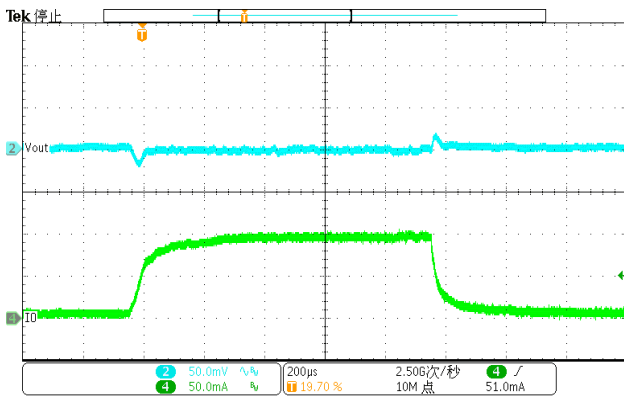

Figure 40. DC-DC Load Transient
(1mA-100mA), $V_{OUT}=5V$

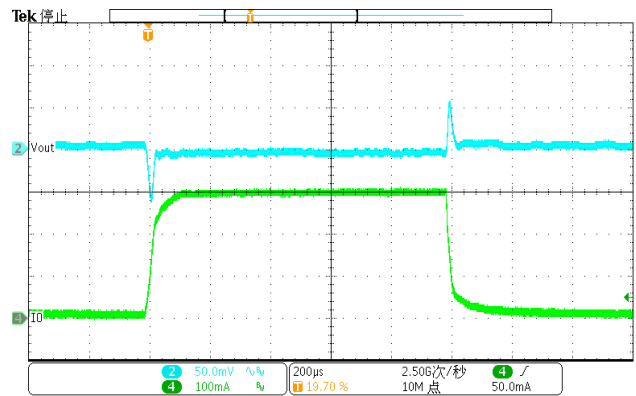

Figure 41. DC-DC Load Transient
(1mA-300mA), $V_{OUT}=5V$

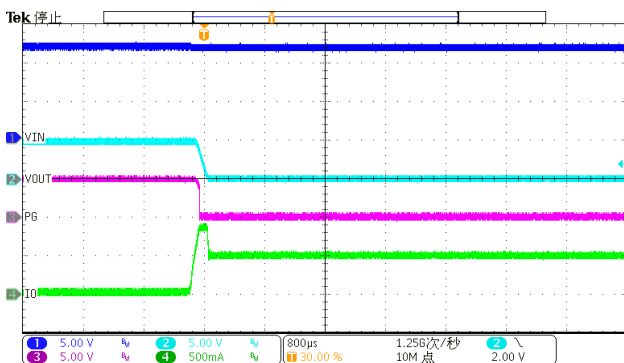

Figure 42. Enter Short Circuit Protection

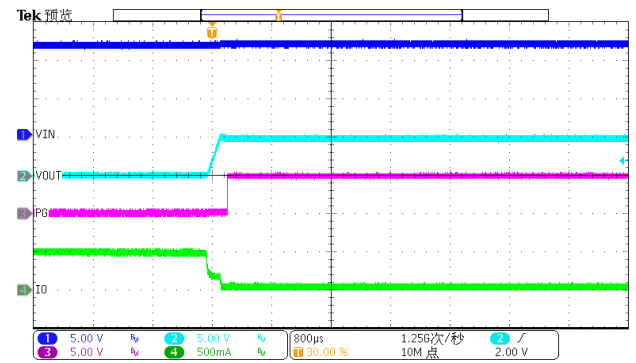

Figure 43. Exit Short Circuit Protection

SCT71203 Series

LAYOUT GUIDELINE

Proper PCB layout is a critical for SCT71203's stability, transient performance and good regulation characteristics. For better results, follow these guidelines as below:

1. Both input capacitors and output capacitors must be placed as close to the device pins as possible.
2. It is recommended to bypass the input pin to ground with a 0.1 μ F bypass capacitor. The loop area formed by the bypass capacitor connection, V_{IN} pin and the GND pin of the system must be as small as possible.
3. It is recommended to use wide trace lengths or thick copper weight to minimize $I \times R$ drop and heat dissipation.
4. If using large electrolytic capacitor with high ESR resistor, SCT recommends adding a 10uF low ESR capacitor parallel connection with the large electrolytic capacitor.

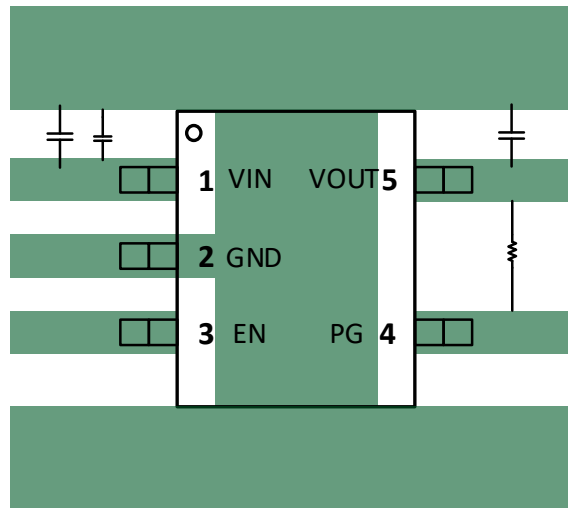
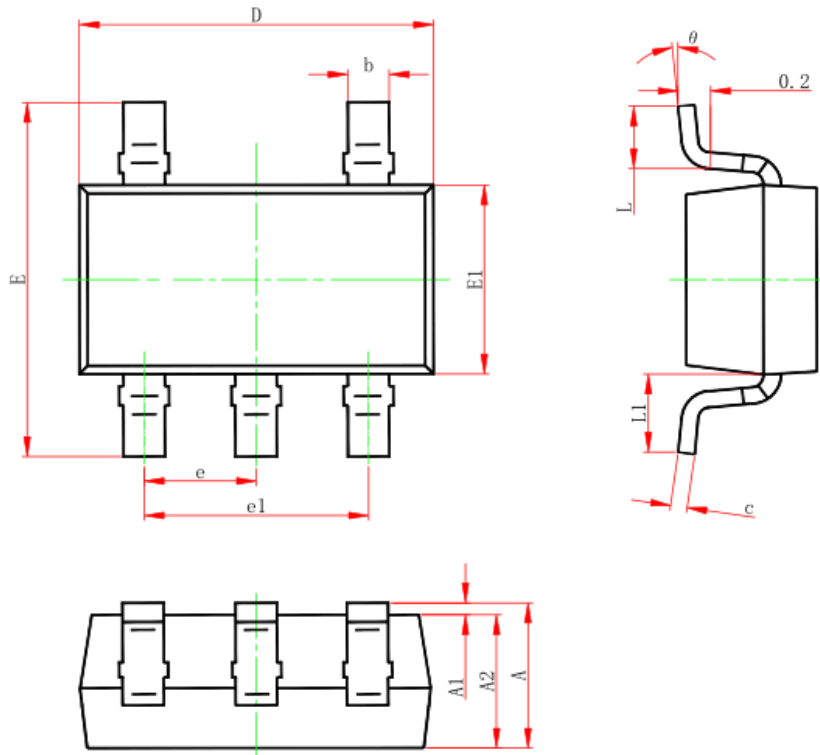

Figure 44. PCB Layout Example

PACKAGE INFORMATION



SOT23-5L Package Outline Dimensions

Symbol	Dimensions in Millimeters		Dimensions in Inches	
	Min.	Max.	Min.	Max.
A	1.050	1.250	0.041	0.049
A1	0.000	0.100	0.000	0.004
A2	1.050	1.150	0.041	0.045
b	0.300	0.500	0.012	0.020
c	0.100	0.200	0.004	0.008
D	2.820	3.020	0.111	0.119
E1	1.500	1.700	0.059	0.067
E	2.650	2.950	0.104	0.116
e	0.950 (BSC)		0.037 (BSC)	
e1	1.800	2.000	0.071	0.079
L	0.300	0.600	0.012	0.024
L1	0.600 REF		0.024 REF	
θ	0°	8°	0°	8°

NOTE:

1. Drawing proposed to be made a JEDEC package outline MO-220 variation.
2. Drawing not to scale.
3. All linear dimensions are in millimeters.
4. Thermal pad shall be soldered on the board.
5. Dimensions of exposed pad on bottom of package do not include mold flash.
6. Contact PCB board fabrication for minimum solder mask web tolerances between the pins.

SCT71203 Series

TAPE AND REEL INFORMATION

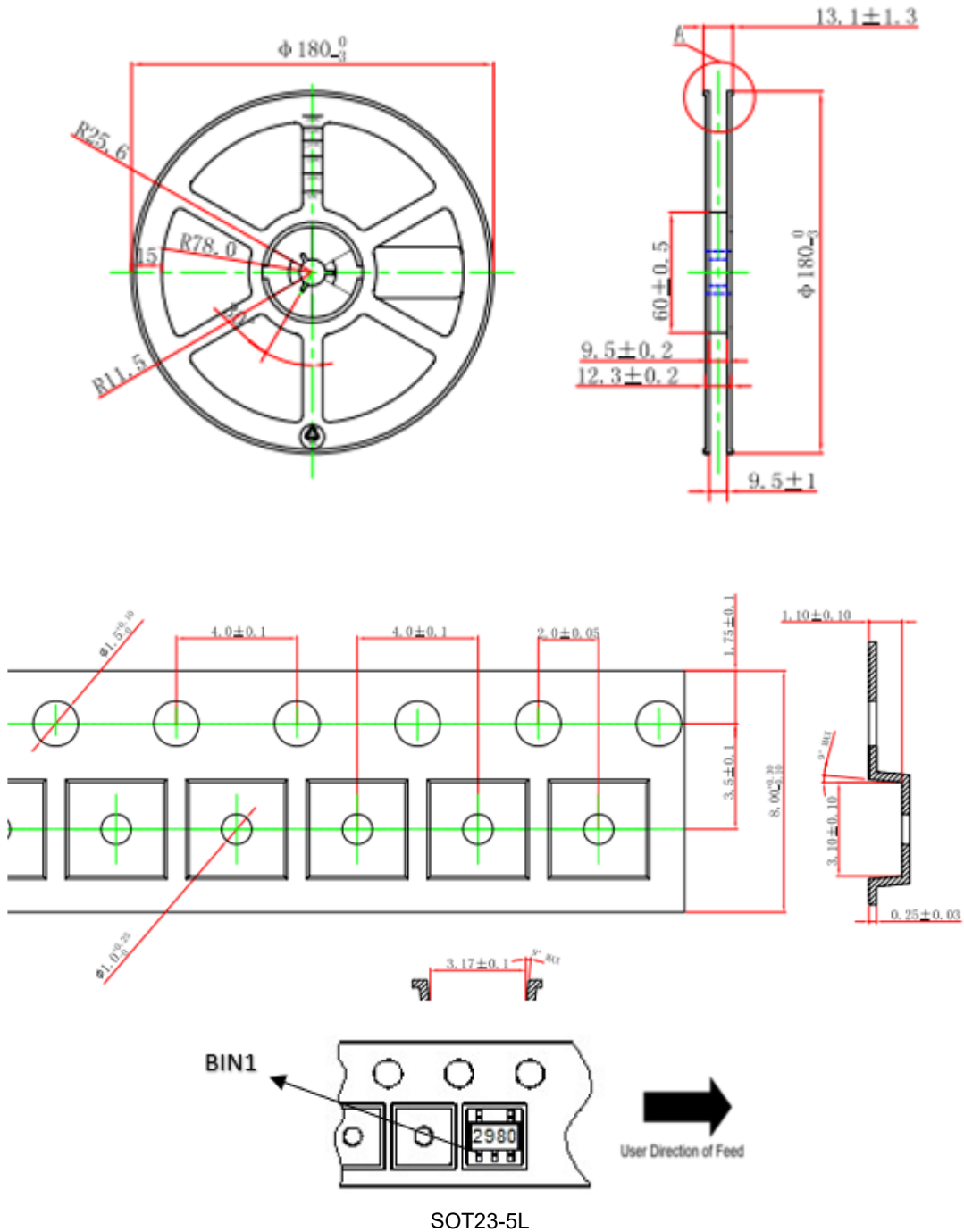

SOT23-5L

NOTICE: The information in this document is subject to change without notice. Users should warrant and guarantee the third party Intellectual Property rights are not infringed upon when integrating Silicon Content Technology (SCT) products into any application. SCT will not assume any legal responsibility for any said applications.