

3V-40V Vin, 300mA, 2.4uA Iq, Low-Dropout Regulator with PG Feature

FEATURES

- Qualified for Automotive Applications
- AEC-Q100 Qualified
- Wide Input Range: 3V-40V
- With up to 45V Transient Input Voltage
- Maximum Output Current: 300mA
- Output Voltage:
 - 3.3V and 5V (Fixed Output)
 - 1.2V, 1.8V, 2.5V, 3V, 4.2V and 4.5V (Need contact SCT sales)
- Output Voltage Accuracy:
 - $T_J = 25^{\circ}\text{C}$: $\pm 1\%$
 - $T_J = -40^{\circ}\text{C} \sim 150^{\circ}\text{C}$: $\pm 2\%$
- Low Quiescent Current: 2.4uA
- Low Dropout Voltage :
 - 230mV at 100mA load current
 - 470mV at 200mA load current
- Support Output Capacitors Range:
 - 3.3uF~220uF
 - Low-ESR: 0.001Ω~ 5 Ω
- 550us Internal Soft-start Time
- Integrated Short-Circuit Protection with OCFB (Over Current Fold-back) Feature
- Precision Enable Threshold for Programmable Input Voltage Under-Voltage Lock Out Protection (UVLO) Threshold and Hysteresis
- Power-Good Feature is available
- Over-Temperature Protection
- Available Package:
 - SOT23-5L / TQFN2X2-6L / EMSOP-8L / TQFN3X3-8L/SOT223-4L

APPLICATIONS

- Automotive Head Units
- Headlights
- Body Control Modules
- Inverter and Motor Controls

DESCRIPTION

The SCT71403Q series products is a low-dropout linear regulator designed to operate with a wide input-voltage range from 3 V to 40 V (45V transient input voltage) and 300mA output current with enable control and Power-Good feature. The SCT71403Q series products is stable with 3.3uF~220uF output capacitors, and 10uF ceramic capacitor is recommended.

Only 2.4-μA typical quiescent current at light load makes the SCT71403Q series products ideal choices for portable devices with battery power supply and an optimal solution for powering microcontrollers (MCUs) and CAN/LIN transceivers in always-on systems.

The SCT71403Q series products implements power good circuit (PG) which indicates that output voltage is in regulation. This signal could be used for power sequencing or as a microcontroller reset.

The SCT71403Q series products integrated short-circuit and overcurrent protection with OCFB (Over Current Fold-back) feature, which makes the device more reliable during transient high-load current faults or shorting events.

The SCT71403Q series products provide fixed 3.3V and 5V output voltage versions, and also could provide 1.2V, 1.8V, 2.5V, 3V, 4.2V and 4.5V fixed output voltage versions, please contact SCT sales if needed.

The SCT71403Q series products is available in SOT23-5L, TQFN2X2-6L, TQFN3X3-8L, EMSOP-8L and SOT223-4L packages, for other package options, please contact SCT sales.

TYPICAL APPLICATION

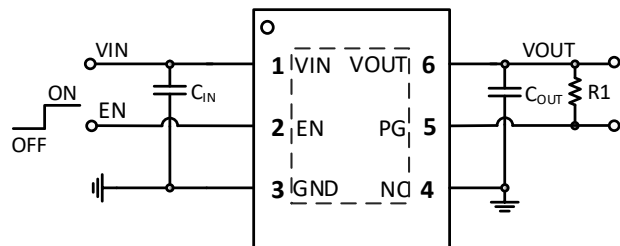

SCT71403Q Series

REVISION HISTORY

NOTE: Page numbers for previous revisions may differ from page numbers in the current version.

Revision 1.0: Release to production.

Revision 1.1: Update Part Number.

Revision 1.2: Update FEATURES on page1.

Revision 1.3: Update DEVICE ORDER INFORMATION and TAPE AND REEL INFORMATION.

Revision 1.4: Update MSL level and add test condition for Load regulation.

Revision 1.5: Update Load regulation.

Revision 1.6: Update Line regulation.

DEVICE ORDER INFORMATION

Orderable Device	Output Voltage	Package	Package Marking	PINS	MSL	Transport Media, Quantity
SCT71403F50AQDVAR	Fixed 5.0V	TQFN2X2-6L	50AQ	6	1	Tape & Reel, 3000
SCT71403F33AQDVAR	Fixed 3.3V	TQFN2X2-6L	33AQ	6	1	Tape & Reel, 3000
SCT71403F50QDVAR	Fixed 5.0V	TQFN2X2-6L	F50Q	6	1	Tape & Reel, 3000
SCT71403F33QDVAR	Fixed 3.3V	TQFN2X2-6L	F33Q	6	1	Tape & Reel, 3000
SCT71403F50QMTER	Fixed 5.0V	EMSOP-8L	F50Q	8	3	Tape & Reel, 4000
SCT71403F33QMTER	Fixed 3.3V	EMSOP-8L	F33Q	8	3	Tape & Reel, 4000
SCT71403F50QTWDR	Fixed 5.0V	SOT23-5L	F50Q	5	3	Tape & Reel, 3000
SCT71403F33QTWDR	Fixed 3.3V	SOT23-5L	F33Q	5	3	Tape & Reel, 3000
SCT71403F50QDTBR	Fixed 5.0V	TQFN3X3-8L	F50Q	8	1	Tape & Reel, 5000
SCT71403F33QDTBR	Fixed 3.3V	TQFN3X3-8L	F33Q	8	1	Tape & Reel, 5000
SCT71403F50QTXER	Fixed 5.0V	SOT223-4L	F50Q	3	3	Tape & Reel, 2500
SCT71403F33QTXER	Fixed 3.3V	SOT223-4L	F33Q	3	3	Tape & Reel, 2500

PIN CONFIGURATION

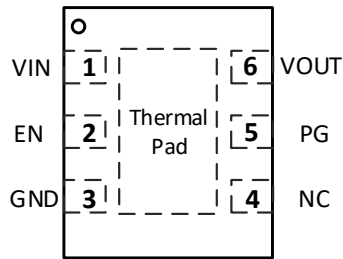

SCT71403FxxAQDVAR
TQFN2X2-6L Package

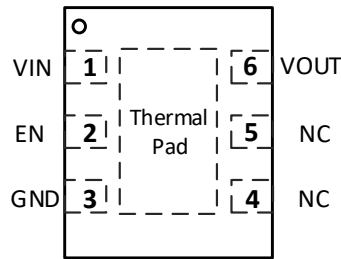

SCT71403FxxQDVAR
TQFN2X2-6L Package

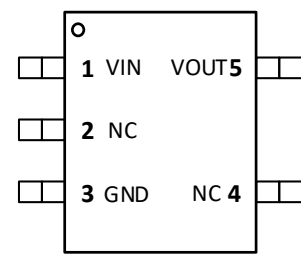

SCT71403FxxQTWDR
SOT23-5L Package

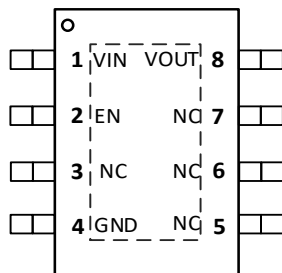

SCT71403FxxQMTER
EMSOP-8L Package

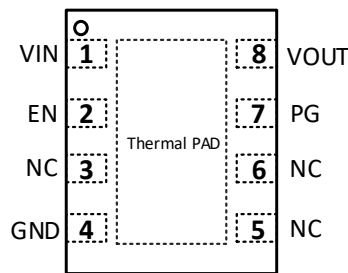

SCT71403FxxQDTBR
TQFN3X3-8L Package

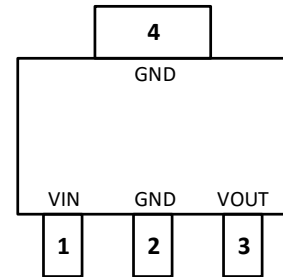

SCT71403FxxQTXER
SOT223-4L Package

PIN FUNCTIONS

NAME	PIN NUMBER						PIN FUNCTION
	TQFN2X2-6L-A	TQFN2X2-6L	EMSOP-8L	SOT23-5L	TQFN3X3-8L	SOT223-4L	
VIN	1	1	1	1	1	1	Input voltage pin
EN	2	2	2	--	2	--	Enable input pin
GND	3	3	4	3	4	2,4	Ground reference pin.
NC	4	4,5	3,5,6,7	2,4	3,5,6	--	No connection
PG	5	--	--	--	7	--	Power-good pin
VOUT	6	6	8	5	8	3	Regulated output voltage pin
Thermal Pad	7	7	9	--	9	--	Connect the thermal pad to a large area GND plane for improved thermal performance.

SCT71403Q Series

RECOMMENDED OPERATING CONDITIONS

Over operating free-air temperature range unless otherwise noted

PARAMETER	DEFINITION	MIN	MAX	UNIT
V _{IN}	Input voltage range	3	40	V
V _{OUT}	Output voltage range	1.2	5	V
V _{EN}	Enable input voltage	0	V _{IN}	V
V _{PG}	Power-good pin voltage	0	5	V
C _{IN}	Input capacitor	2.2	--	uF
C _{OUT}	Output capacitor	3.3	220	uF
ESR	Output capacitor ESR requirements	0.001	5	Ω
T _J	Operating junction temperature	-40	150	°C

ABSOLUTE MAXIMUM RATINGS

Over operating free-air temperature range unless otherwise noted ⁽¹⁾

PARAMETER	DEFINITION	MIN	MAX	UNIT
V _{IN}	Maximum input voltage range	-0.3	45	V
V _{OUT}	Maximum output voltage range	-0.3	5.5	V
V _{EN}	Maximum enable input voltage	-0.3	V _{IN}	V
V _{PG}	Maximum power-good pin voltage	-0.3	5.5	V
T _J ⁽²⁾	Junction temperature range	-40	150	°C
T _{stg}	Storage temperature range	-65	150	°C

- (1) Stresses beyond those listed under Absolute Maximum Rating may cause device permanent damage. The device is not guaranteed to function outside of its Recommended Operation Conditions.
- (2) The IC includes over temperature protection to protect the device during overload conditions. Junction temperature will exceed 150°C when over temperature protection is active. Continuous operation above the specified maximum operating junction temperature will reduce lifetime.

ESD RATINGS

PARAMETER	DEFINITION	MIN	MAX	UNIT
V _{ESD}	Human Body Model(HBM), per ANSI-JEDEC-JS-001-2014 specification, all pins	-3	+3	kV
	Charged Device Model(CDM), per ANSI-JEDEC-JS-002-2014 specification, all pins	-1	+1	kV

THERMAL INFORMATION

The value of $R_{\theta JA}$ and $R_{\theta JC}$ given in this table is only valid for comparison with other packages and cannot be used for design purposes. Because they were simulated in accordance with JESD 51-7. They do not represent the performance obtained in an actual application. For design information see Power Dissipation and Thermal Performance section.

The value of $R_{\theta JA_EVM}$ is the tested results based on our EVM, and is more useful for thermal design. Even if it still do not represent the thermal performance of customer's PCB design, but it was a good starting point for thermal performance design.

The PCB information of our EVM: 2-layer, 1 oz Cu, 50mm x 30mm size.

The values given in this table are not a characteristic of package itself, but of many other system level characteristics such as the design and layout of the printed circuit board (PCB), thermal pad size, and external environmental factors. The PCB board is a heat sink that is soldered to the leads and thermal pad of the device. Changing the design or configuration of the PCB board changes the efficiency of the heat sink and therefore the actual values of the below table.

Package Type	$R_{\theta JA}^{(1)}$	$R_{\theta JC}^{(2)}$	$R_{\theta JA_EVM}^{(3)}$	UNIT
TQFN2X2-6L	93.7	26.1	62.5	°C/W
EMSOP-8L	81.1	22.5	51.2	
SOT23-5L	161.1	/	115.4	
TQFN3X3-8L	72.2	25.4	60	
SOT223-4L	64.0	/	46.0	

(1) $R_{\theta JA}$ is junction to ambient thermal resistance, based on JESD51-7.

(2) $R_{\theta JC}$ is junction to case thermal resistance, based on JESD51-7.

(3) $R_{\theta JA_EVM}$ is junction to ambient thermal resistance, which is tested on SCT EVM.

SCT71403Q Series

ELECTRICAL CHARACTERISTICS

$V_{IN}=V_{OUT}+1V$, $C_{OUT}=10\mu F$, $T_J=-40^{\circ}C\sim 150^{\circ}C$, typical value is tested under $25^{\circ}C$.

SYMBOL	PARAMETER	TEST CONDITION	MIN	TYP	MAX	UNIT
Power Supply						
V_{IN}	Operating input voltage		3		40	V
V_{UVLO}	V_{IN} UVLO Threshold Hysteresis	V_{IN} rising	2.3	2.66 180	2.9	V mV
I_{SHDN}	Shutdown current from V_{IN} pin	$EN=0$, $V_{OUT}=3.3V$, $V_{IN}=4.3V$		0.25		μA
		$EN=0$, $V_{OUT}=5V$, $V_{IN}=6V$		0.4		μA
		$EN=0$, $V_{OUT}=3.3V/5V$, $V_{IN}=12V$		0.6		μA
I_Q	Quiescent current from GND pin	EN float, no load, $V_{IN}=V_{OUT}+1V$		2.4		μA
		EN float, no load, $V_{IN}=12V$		2.6		μA

Regulated Output Voltage and Current

V_{OUT}	Output voltage accuracy	$T_J=25^{\circ}C$	-1%		1%	
		$T_J=-40^{\circ}C\sim 150^{\circ}C$	-2%		2%	
ΔV_{OUT}	Line regulation	$V_{IN}=V_{OUT}+1V$ to 40V, or $V_{IN}>3V$, $I_{OUT}=10mA$		1	20	mV
	Load regulation	$I_{OUT}=1mA$ to 300mA(TQFN3X3-8L、TQFN2X2-6L、SOT23-5L)		15	50	mV
		$I_{OUT}=1mA$ to 300mA(EMSOP8)		15	60	mV
		$I_{OUT}=1mA$ to 300mA(SOT223-4L)		28	70	mV
V_{DROP}	Dropout voltage ⁽¹⁾	$V_{IN}=V_{OUT}-0.1V$, $I_{OUT}=100mA$		230		mV
		$V_{IN}=V_{OUT}-0.1V$, $I_{OUT}=200mA$		470		mV
		$V_{IN}=V_{OUT}-0.1V$, $I_{OUT}=300mA$		730		mV
I_{OUT}	Output current	V_{OUT} in regulation	0		300	mA
I_{OC}	Output current limit	V_{OUT} short to $90\% \times V_{OUT}$		500		mA
I_{SC}	Short current limit	$V_{OUT}=0V$		90		mA
PSRR	Power supply rejection ratio ⁽²⁾	$I_{OUT}=10mA$, $f=1kHz$, $C_{OUT}=10\mu F$		75		dB
		$I_{OUT}=10mA$, $f=10kHz$, $C_{OUT}=10\mu F$		50		dB
		$I_{OUT}=10mA$, $f=100kHz$, $C_{OUT}=10\mu F$		45		dB

Enable and Soft-startup

V_{EN_H}	Enable high threshold			1.23		V
V_{EN_L}	Enable low threshold			1.02		V
V_{EN_Hys}	Enable threshold hysteresis			210		mV
I_{EN_0V}	Enable pin pull-up current	$EN=0V$		0.35		μA
T_{SS}	Soft-start time			550		us

Power Good

V_{PG_R}	PG rising threshold percentage	$V_{OUT}/V_{OUT(NOM)}$, when V_{OUT} rising		91%		
V_{PG_F}	PG falling threshold percentage	$V_{OUT}/V_{OUT(NOM)}$, when V_{OUT} falling		85%		
V_{PG_LOW}	PG output low voltage	$V_{OUT}=0.8 \times V_{OUT(NOM)}$, PG sink 500uA		44		mV
R_{PG}	PG pull down resistor	$R_{PG}=V_{PG_LOW}/0.5mA$		88		Ω
I_{PG_LKG}	PG leakage current	$PG=5V$, V_{OUT} in regulation		20		nA

SCT71403Q Series

SYMBOL	PARAMETER	TEST CONDITION	MIN	TYP	MAX	UNIT
Td_PGR	PG signal turn to high delay	From $V_{OUT} > 0.91 \times V_{OUT(NOM)}$ to PG rising edge delay time		130		us
Td_PGF	PG signal turn to low delay	From $V_{OUT} < 0.85 \times V_{OUT(NOM)}$ to PG falling edge delay time		12		us

Thermal Protection

T _{SD}	Thermal shutdown threshold ⁽³⁾	T _J rising Hysteresis		170 15		°C °C
-----------------	---	-------------------------------------	--	-----------	--	----------

- (1) The dropout voltage is defined as $V_{IN} - V_{OUT}$, when force V_{IN} is 100mV below the value of V_{OUT} for $V_{IN} = V_{OUT(NOM)} + 1V$.
- (2) PSRR is derived from bench characterization, not production test.
- (3) Thermal shutdown threshold is derived from bench characterization, not production test.

SCT71403Q Series

TYPICAL CHARACTERISTICS

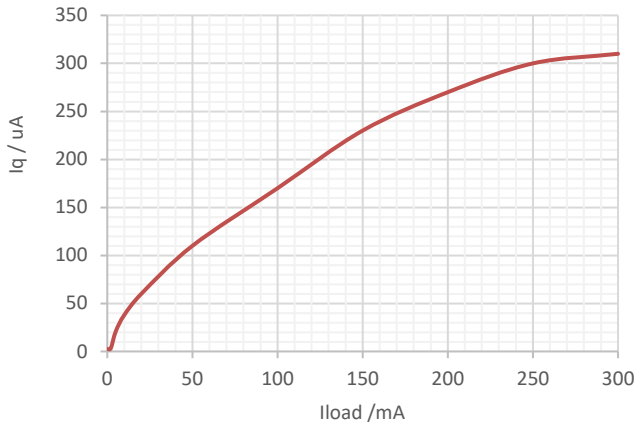

Figure 1. Quiescent Current vs Output Current

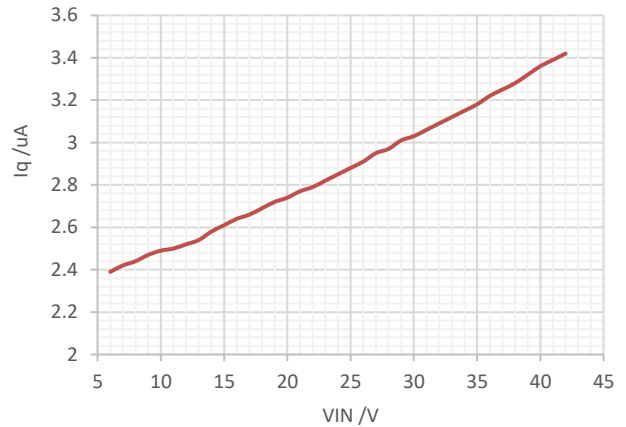

Figure 2. Quiescent Current vs Input Voltage, No load

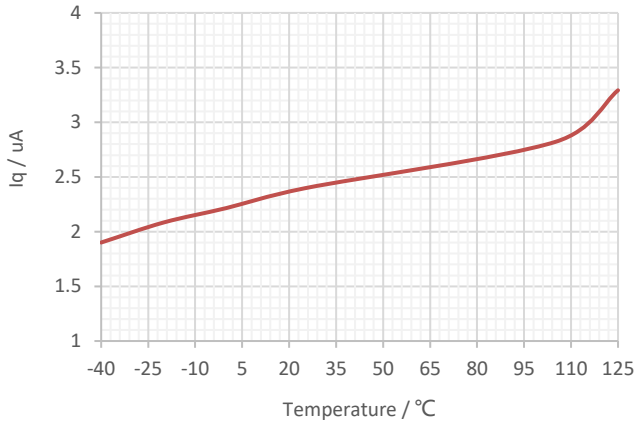

Figure 3. Quiescent Current vs Ambient Temperature

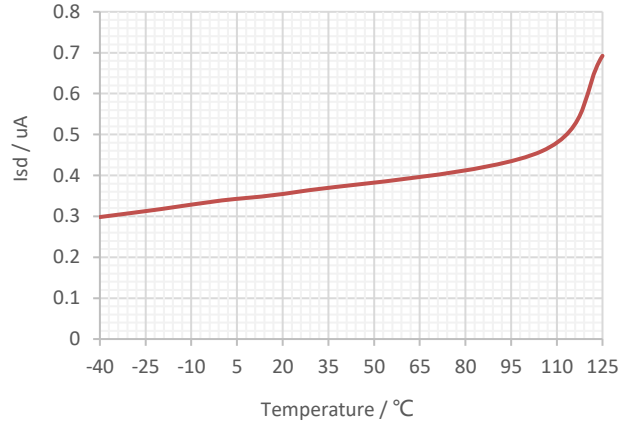

Figure 4. Shutdown Current vs Ambient Temperature

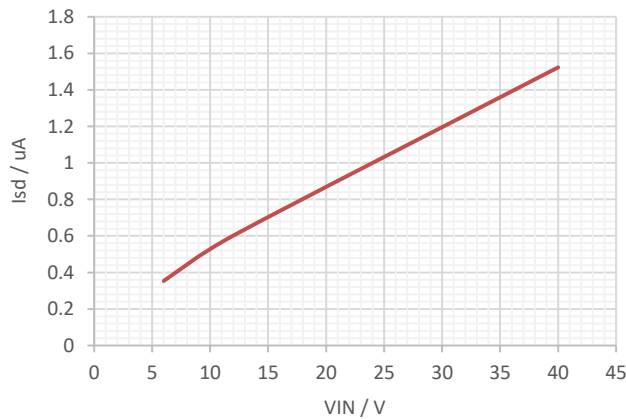

Figure 5. Shutdown Current vs Input Voltage

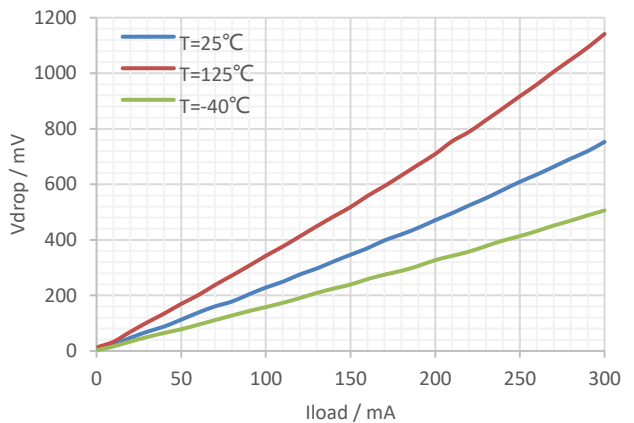

Figure 6. Dropout Voltage vs Output Current

TYPICAL CHARACTERISTICS (continued)

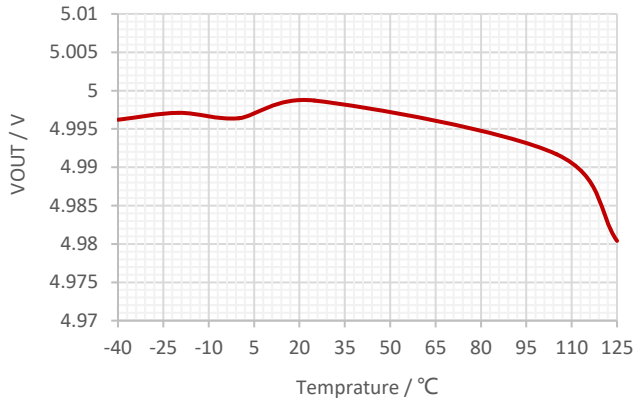

Figure 7. Output Voltage vs Ambient Temperature at VOUT=5V

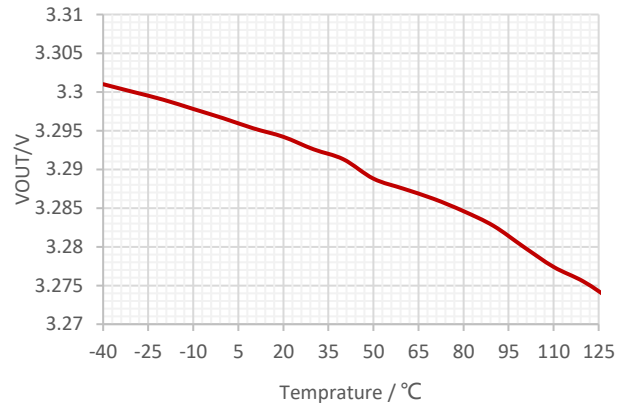

Figure 8. Output Voltage vs Ambient Temperature at VOUT=3.3V

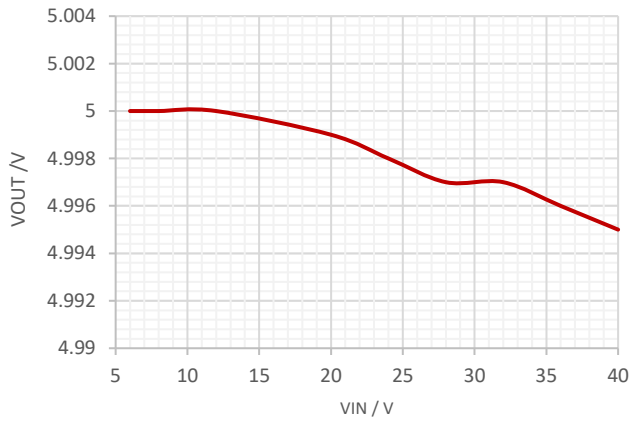

Figure 9. Output Voltage vs Input Voltage

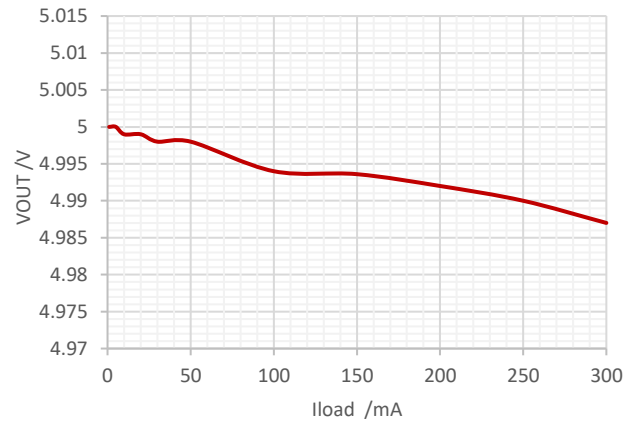

Figure 10. Output Voltage vs Output Current

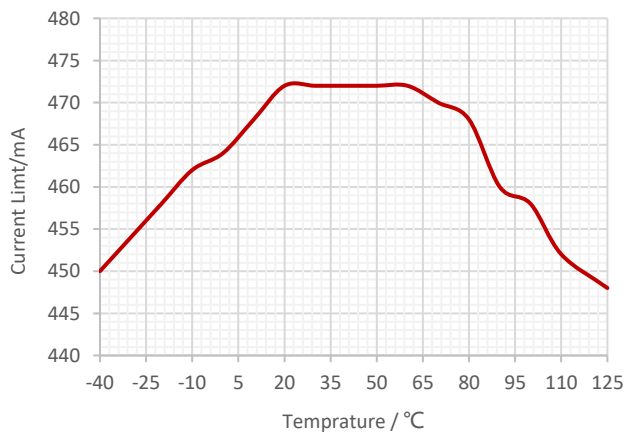

Figure 11. Output Current Limit vs Ambient Temperature

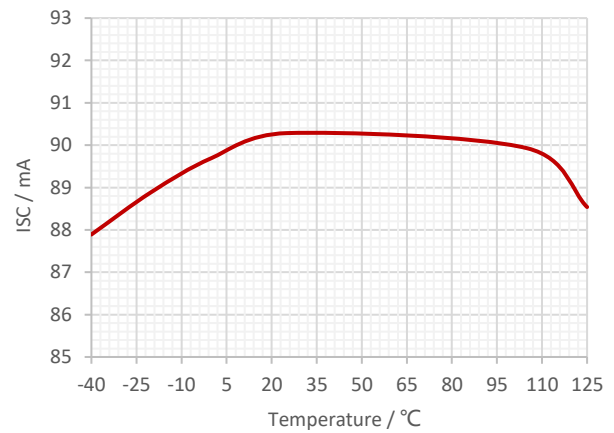

Figure 12. Short Current Limit vs Ambient Temperature

TYPICAL CHARACTERISTICS (continued)

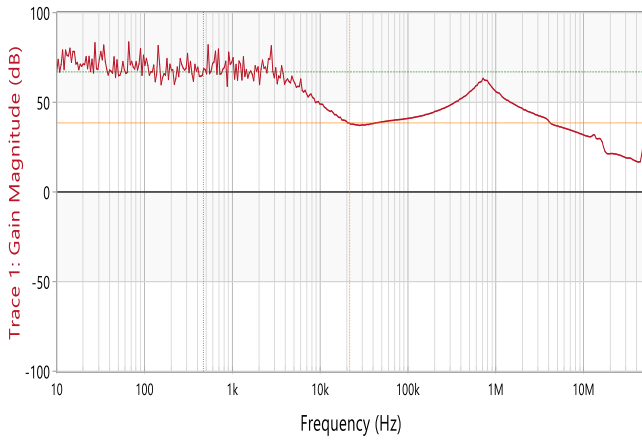

Figure 13. PSRR vs Frequency at $I_{out}=10\text{mA}$, $C_{OUT}=4.7\mu\text{F}$

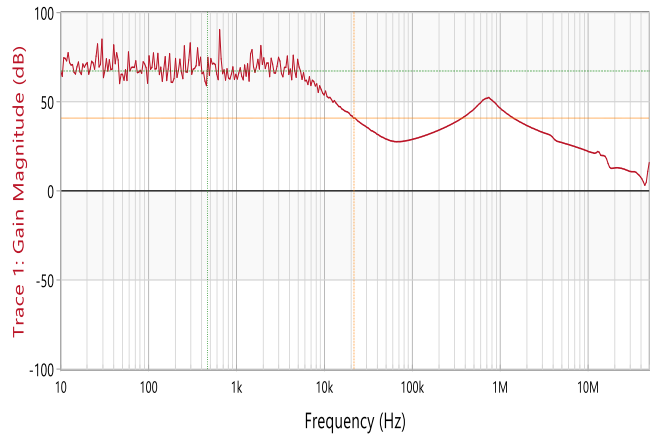

Figure 14. PSRR vs Frequency at $I_{out}=100\text{mA}$, $C_{OUT}=4.7\mu\text{F}$

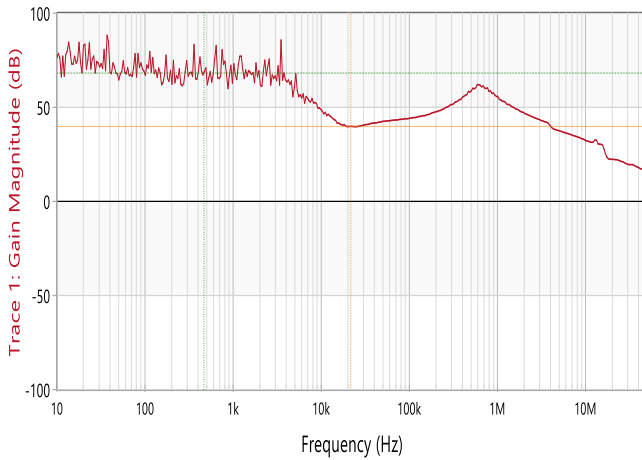

Figure 15. PSRR vs Frequency at $I_{out}=10\text{mA}$, $C_{OUT}=10\mu\text{F}$

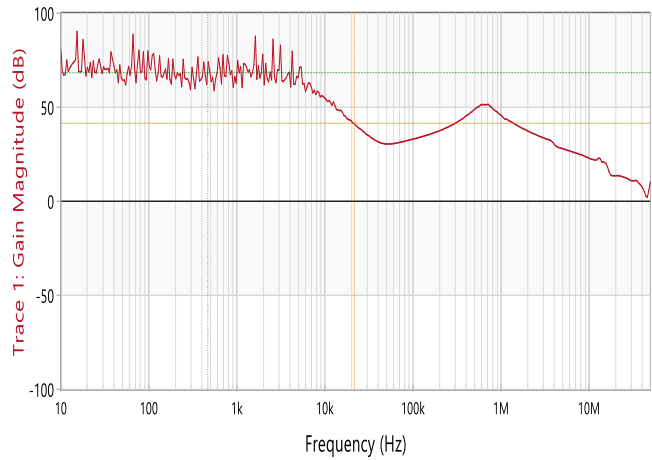

Figure 16. PSRR vs Frequency at $I_{out}=100\text{mA}$, $C_{OUT}=10\mu\text{F}$

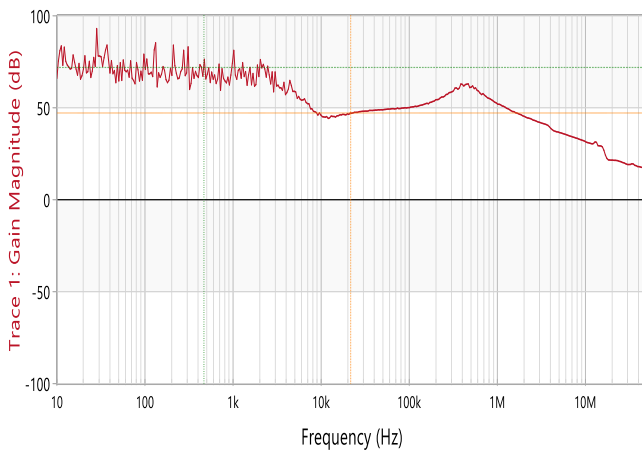

Figure 17. PSRR vs Frequency at $I_{out}=10\text{mA}$, $C_{OUT}=22\mu\text{F}$

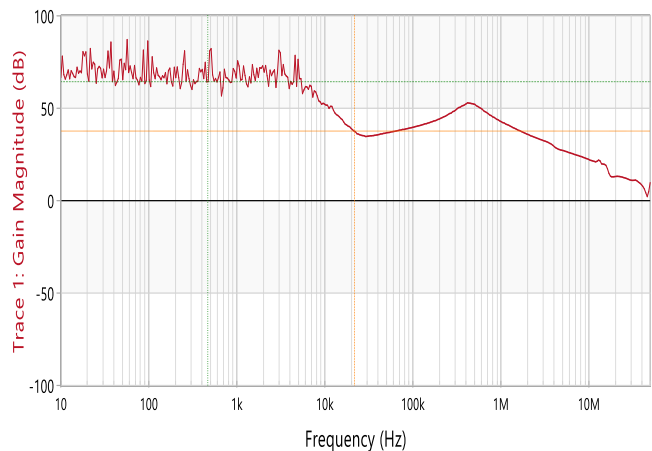

Figure 18. PSRR vs Frequency at $I_{out}=100\text{mA}$, $C_{OUT}=22\mu\text{F}$

FUNCTIONAL BLOCK DIAGRAM

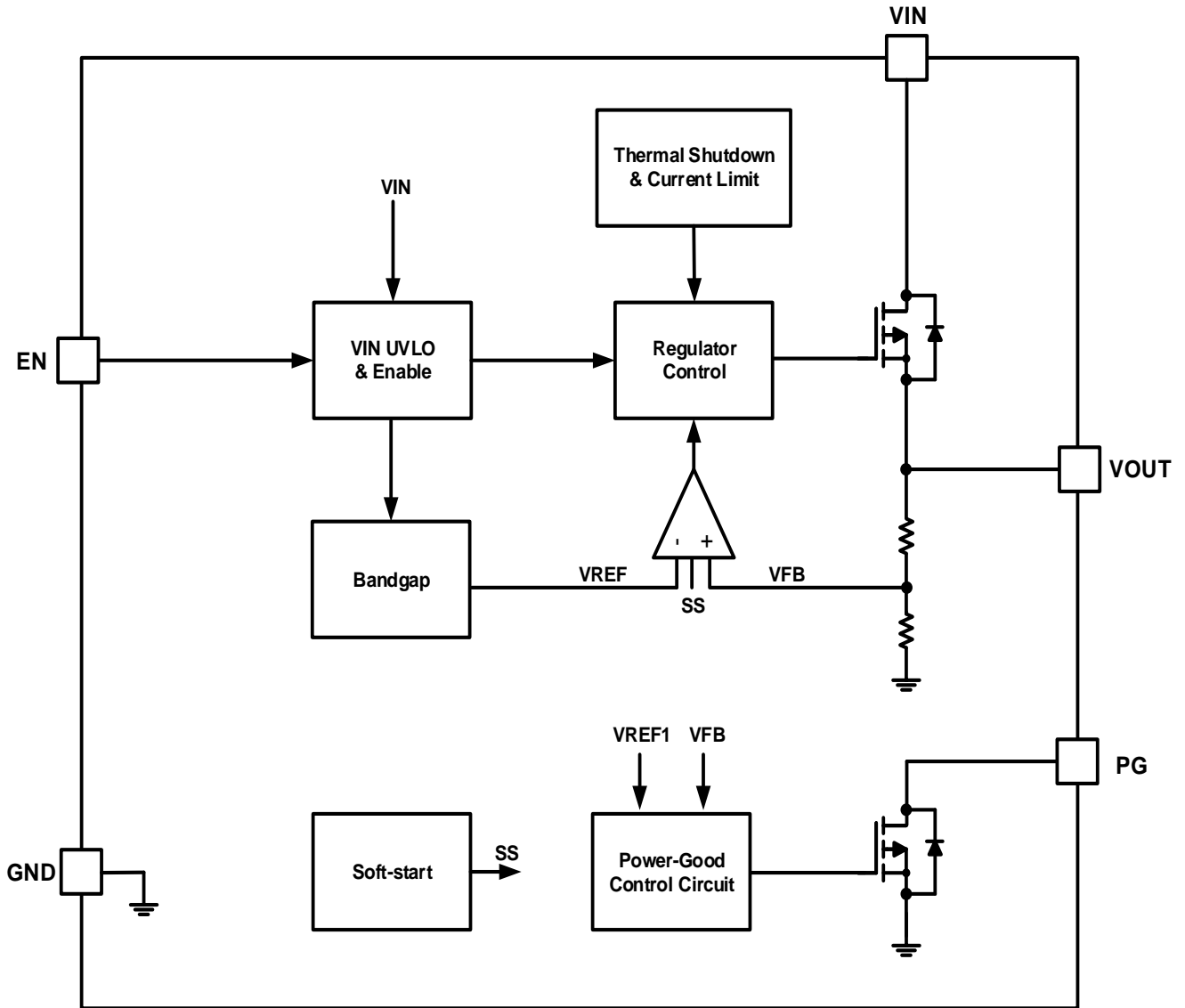

Figure 19. Functional Block Diagram

SCT71403Q Series

OPERATION

Overview

The SCT71403Q series products are 300mA wide input voltage range linear regulators with very low quiescent current. These voltage regulators operate from 3V to 40V DC input voltage with supporting 45V transient input voltage and consume 2.4µA quiescent current at no load.

The SCT71403Q series products is stable with 3.3µF~220µF output capacitors, and 10µF ceramic capacitor is recommended. An internal 550us soft-start time avoids large inrush current and output voltage overshoot during startup.

The SCT71403Q series products also provide enable control and Power-Good feature, which is very suitable for the applications needing sequence configuration. Other protection features include the VIN input under-voltage lockout, over current protection, output hard short protection and thermal shutdown protection.

The SCT71403Q series products are available in fixed voltage versions of 3.3V and 5V with 1% output voltage accuracy at room temp and 2% output voltage accuracy over operating conditions. The series products are available in SOT23-5L, TQFN2X2-6L, TQFN3X3-8L, EMSOP-8L and SOT223-4L packages.

The SCT71403Q series products also could provide other fixed output voltage versions of 1.2V, 1.8V, 2.5V, 3V, 4.2V and 4.5V and other package options of SOT23-3, TO252-5 etc. Please feel free to contact SCT sales, if you need a new output voltage version or a new package option.

Enable and Under Voltage Lockout Threshold

The SCT71403Q series products is enabled when the VIN pin voltage rises above 3V and the EN pin voltage exceeds the enable threshold V_{EN_H} . The device is disabled when the VIN pin voltage falls below 2.48V or when the EN pin voltage is below V_{EN_L} . Internal pull up current source to EN pin allows the device enable when EN pin floats.

For a higher system UVLO threshold, connect an external resistor divider (R1 and R2) from VIN to GND shown in Figure 20. The UVLO rising and falling threshold can be calculated by Equation 1 and Equation 2 respectively.

$$VIN_{rise} = V_{EN_H} * \frac{R1 + R2}{R2} \quad (1)$$

$$VIN_{hys} = (V_{EN_H} - V_{EN_L}) * \frac{R1 + R2}{R2} \quad (2)$$

Where

VIN_{rise} : Vin rise threshold to enable the device

VIN_{hys} : Vin hysteresis threshold

$I_1=0.34\mu A$ and could be neglected in the calculation

$V_{EN_H}=1.23V$

$V_{EN_L}=1.02V$

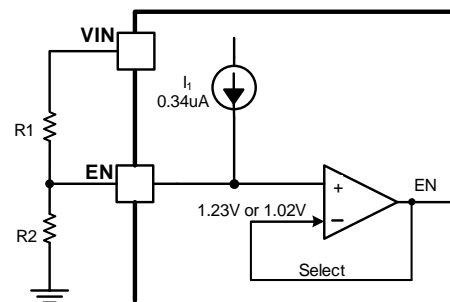

Figure 20. System UVLO by enable divide

Regulated Output Voltage

The SCT71403Q series are available in fixed voltage versions of 3.3V and 5V. When the input voltage is higher than $V_{OUT(NOM)}+V_{DROP}$, output pin is the regulated output based on the selected voltage version. When the input voltage falls below $V_{OUT(NOM)}+V_{DROP}$, output pin tracks the input voltage minus the dropout voltage based on the load current.

When the input voltage drops below UVLO threshold, the output keeps shut off.

The SCT71403Q series products also could provide other fixed output voltage versions of 1.2V, 1.8V, 2.5V, 3V, 4.2V and 4.5V and other package options of SOT23-3, TO252-5 etc. Please feel free to contact SCT sales, if you need

a new output voltage version or a new package option.

Over Current Limit and Foldback Current Limit

The SCT71403Q series products has an internal current limit circuit that protects the regulator during transient high-load current faults or shorting events. The current limit is a hybrid brick-wall foldback scheme. The current limit transitions from a brick-wall scheme to a foldback scheme at the foldback voltage ($V_{FOLDBACK}$). In a high-load current fault with the output voltage above $V_{FOLDBACK}$, the brick-wall scheme limits the output current to the current limit (I_{OC}). When the output voltage drops below $V_{FOLDBACK}$, a foldback current limit activates that scales back the current limit. When the output is shorted, the device supplies a typical current called the short-circuit current limit (I_{SC}). I_{OC} and I_{SC} are listed in the Electrical Characteristics table.

The output voltage is not regulated when the device is in current limit. When a current limit event occurs, the regulator begins to heat up because of the increase in power dissipation. When the device is in brick-wall current limit, the pass transistor dissipates power $[(V_{IN}-V_{OUT}) \times I_{OC}]$. When the output is shorted and the output voltage is less than $V_{FOLDBACK}$, the pass transistor dissipates power $[(V_{IN}-V_{OUT}) \times I_{SC}]$. If thermal shutdown is triggered, the device turns off. After the device cools down, the internal thermal shutdown circuit turns the device back on. If the output current fault condition persists, the device cycles between current limit and thermal shutdown.

The foldback voltage ($V_{FOLDBACK}$) of SCT71403Q series products was set to $[50\% \times V_{OUT(NOM)}]$, when V_{OUT} falling during over current faults or shorting events. And it will recovery to brick-wall scheme from a foldback current limit scheme when the output voltage rises up to $[56\% \times V_{OUT(NOM)}]$, when over current faults or short events disappear.

With the over current foldback limit feature, the SCT71403Q series products would be more robust and safer when over current faults and shorting events occur. But it also requires the maximum loading current should be smaller than I_{SC} during startup and $V_{OUT} < [56\% \times V_{OUT(NOM)}]$, once $V_{OUT} > [56\% \times V_{OUT(NOM)}]$, it will be not limited by I_{SC} any more. The characteristic is shown in the following figure.

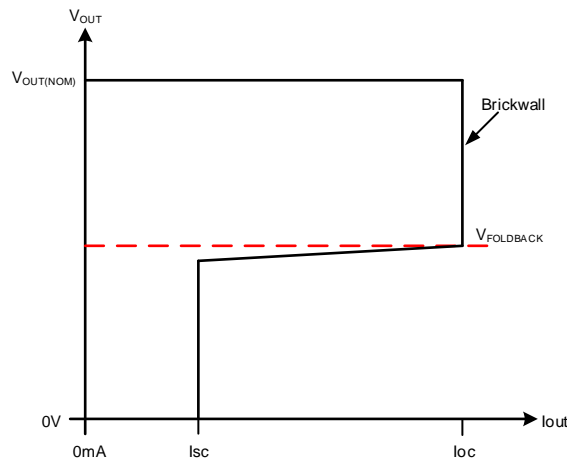

Figure 21. Current Limit with Foldback Feature

Internal Soft-Start

The SCT71403Q series products integrates an internal soft-start circuit that ramps the reference voltage from zero volts to 0.6V reference voltage in 550us. If the EN pin is pulled below 1.02V, LDO will be shut off and the internal soft-start resets. The soft-start also resets during shutdown due to thermal overloading.

Below figure shows the startup waveform at small output capacitor and large output capacitor. When output capacitor is small, for example 10uF, the slope of V_{OUT} is limit by soft-start. When output capacitor is large, for example 100uF, the slope of V_{OUT} is limited by foldback current limit (I_{SC}) at $V_{OUT} < V_{FOLDBACK}$, and the slope of V_{OUT} is limited by over current limit (I_{OC}), when $V_{OUT} > V_{FOLDBACK}$.

In SCT71403Q series products, typical T_{SS} is 550us, and typical I_{OC} is 500mA and typical I_{SC} is 90mA, could use the following formula for initial startup time calculation.

$$T_{start} = \max \left\{ \frac{C_{OUT} \times 0.56 \times V_{OUT}}{(I_{sc} - I_{load})} + \frac{C_{OUT} \times 0.44 \times V_{OUT}}{(I_{oc} - I_{load})}, T_{SS} \right\} \quad (3)$$

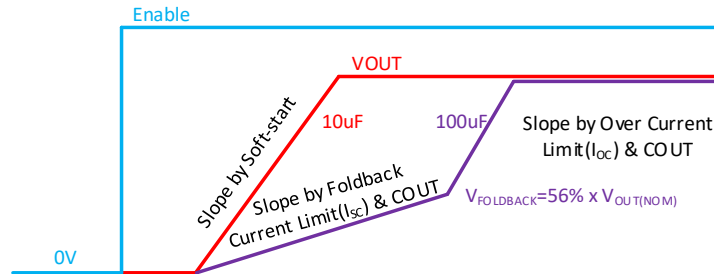

Figure 22. Soft-start Waveform vs Output Capacitor

Power-Good and Power-Good Delay

The power-good (PG) pin is an open-drain output and can be connected to any 5V or lower rail through an external pull-up resistor. And it also could be allowed to connect to power rail higher than 5V, because of integrating a zener diode from PG pin to GND internally, and in this condition, the maximum high level voltage of PG will be clamped as the breakdown voltage of zener diode, which is 5.6V typically. The PG output is high-impedance when V_{OUT} is greater than the PG trip threshold (V_{PG_R}=91% x V_{OUT(NOM)}). If V_{OUT} drops below V_{PG_F}=85% x V_{OUT(NOM)}, the open-drain output turns on and pulls the PG output low. If output voltage monitoring is not needed, the PG pin can be left floating or connected to GND.

The power-good delay time (T_{d_PGR}) is defined as the time period from when V_{OUT} exceeds the PG trip threshold voltage (V_{PG_R}) to when the PG output is high. This power-good delay time is set by an internal time, which is 130us typical. The power-good deglitch time (T_{d_PGF}) is defined as the time period from when V_{OUT} fall below the PG trip threshold voltage (V_{PG_F}) to when the PG output is low. This power-good deglitch time is set by an internal time, which is 12us typical. If the power-good delay time is not enough for some application, could try to connect a capacitor from PG pin to GND and using PG pull-up resistor and this capacitor generate extra delay time to meet your design.

To ensure proper operation of the power-good feature, maintain V_{IN} ≥ 3V (V_{IN_MIN}). It allows connections of PG pin to circuit with the same or different power supply voltage to the LDO's V_{OUT} level. Below are the connections examples.

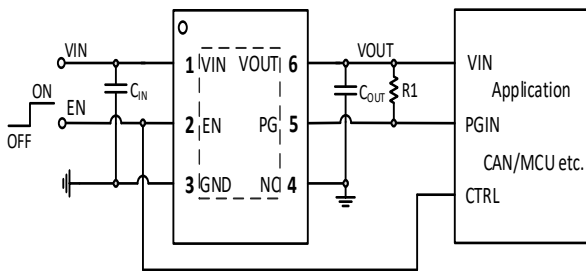

Figure 23. PG Connected to LDO's Output

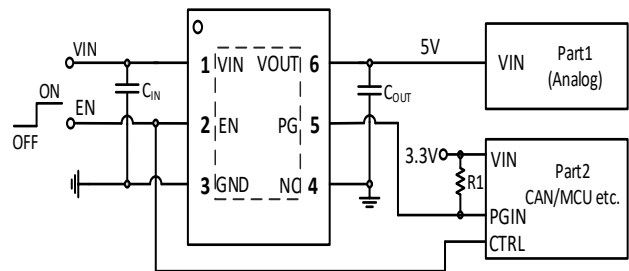

Figure 24. PG Connected to the other Power Supply

Below figure shows the startup and shutdown situation when slow power up and power down.

At the point 0, the input voltage starts to rise from 0 to 6 V, LDO is in shutdown (because V_{IN} is below its UVLO threshold) and output voltage is 0V.

At the point 1, the V_{IN} voltage reaches UVLO threshold level and LDO starts charging of output capacitor. V_{OUT} rising speed is defined by internal soft-start function.

At the point 2, the V_{OUT} voltage reaches almost the V_{IN} voltage as it rises faster and LDO gets into dropout region. The difference between V_{IN} and V_{OUT} is the dropout voltage.

At the point 3, the VOUT reaches PG threshold ($V_{PG_R}=91\% \times V_{OUT(NOM)}$) and from this point LDO counts the power good delay time (Td_PGR). After this delay, the PG pin rises to high level showing that VOUT is ok.

At the point 4, the VOUT reaches its nominal value (5.0V) as the VIN starts to be higher than ($V_{OUT(NOM)} + V_{DROP}$) and LDO gets into regulation region.

At the point 5, as the VIN voltage slow power down and LDO returns to dropout region again.

At the point 6, the VOUT drops below PG threshold ($V_{PG_F}=85\% \times V_{OUT(NOM)}$) and LDO starts counting the power good deglitch time (Td_PGF), which filters fast VOUT undershoots (caused for example by line/load transient responses). After this delay, the PG output is shorted to 0 V level to highlight “power fail” state.

At the point 7, the VIN voltage is lower than input voltage UVLO threshold minus UVLO hysteresis level and LDO goes into the shutdown state.

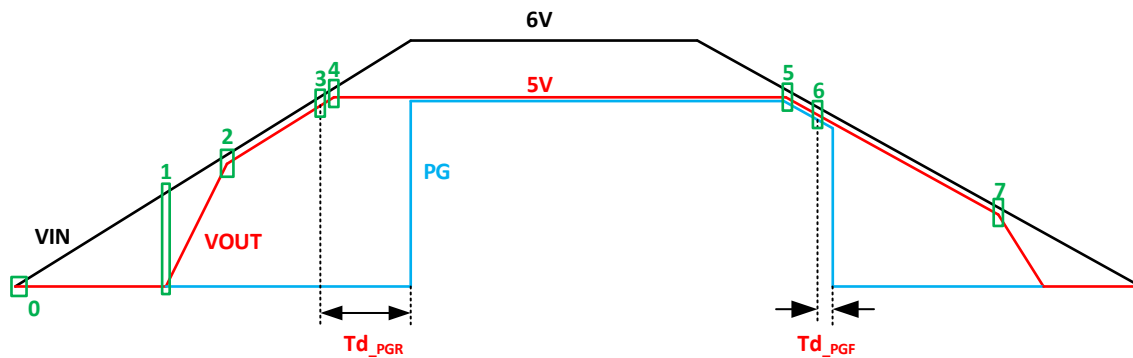

Figure 25. Startup and Shutdown Example —SCT71403Q Series

Thermal Shutdown

This device incorporates a thermal shutdown (T_{SD}) circuit as a protection from overheating. For continuous normal operation, the junction temperature should not exceed the T_{SD} trip point. The junction temperature exceeding the T_{SD} trip point causes the output to turn off. When the junction temperature falls below the T_{SD} trip point minus thermal shutdown hysteresis, the output turns on again.

SCT71403Q Series

APPLICATION INFORMATION

Typical application 1:

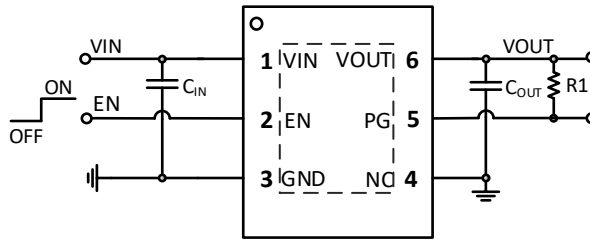

Figure 26. SCT71403Q Typical Application Schematic

Design Parameters

Design Parameters	Example Value
Input Voltage	12V Normal, 3V~40V
Output Voltage	5V or 3.3V
Maximum Output Current	300mA
Output Capacitor Range (C_{OUT})	3.3uF~22uF , recommends 10uF
Input Capacitor Range (C_{IN})	>2.2uF , recommends 10uF
Pull-up resistor of power-good (R1)	>10kΩ

Typical application 2:

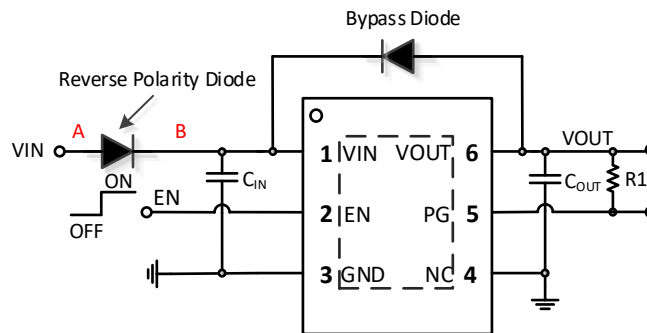

Figure 27. SCT71403Q Typical Application Schematic with Reverse Polarity Diode

Design Parameters

Design Parameters	Example Value
Input Voltage	12V Normal, 3V~40V
Output Voltage	5V or 3.3V
Maximum Output Current	300mA
Output Capacitor Range (C_{OUT})	3.3uF~22uF , recommends 10uF
Input Capacitor Range (C_{IN})	>2.2uF , recommends 10uF
Pull-up resistor of power-good (R1)	>10kΩ

In some applications, the VIN and the VOUT potential might be reversed, possibly resulting in circuit internal damage or damage to the elements. For example, the accumulated charge in the output pin capacitor flowing backward from the VOUT to the VIN when the VIN shorts to the GND. In order to minimize the damage in such case, use a capacitor with a capacitance less than 220 μ F. Also by inserting a reverse polarity diode in series to the VIN, it can prevent reverse current from reverse battery connection or the case, when the point A is short-circuited GND. If there may be any possible case point B is short-circuited to GND, we also recommend using a bypass diode between the VIN and the VOUT.

Typical application 3:

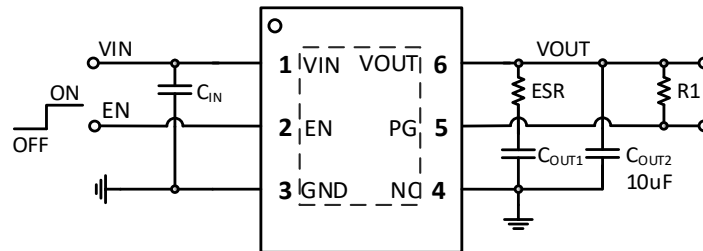

Figure 28. SCT71403Q Typical Application Schematic with Large Output Capacitor

Design Parameters

Design Parameters	Example Value
Input Voltage	12V Normal, 3V~40V
Output Voltage	5V or 3.3V
Maximum Output Current	300mA
Output Capacitor Range (C _{OUT1} and ESR)	3.3 μ F~220 μ F with ESR=0.5 Ω ~5 Ω
Output Capacitor Range (C _{OUT2})	recommends 10 μ F with low ESR
Input Capacitor Range (C _{IN})	>2.2 μ F , recommends 10 μ F
Pull-up resistor of power-good (R1)	>10k Ω

SCT71403Q Series

Input Capacitor and Output Capacitor

SCT recommends adding a 2.2μF or greater capacitor with a 0.1μF bypass capacitor in parallel at VIN pin to keep the input voltage stable. Aluminum electrolytic capacitor or other capacitor with high capacitance is suggested for the system power with large voltage spike. The voltage rating of the capacitors must be greater than the maximum input voltage

To ensure loop stability, the SCT71403Q series products requires an output capacitor with a minimum effective capacitance value of 3.3μF. And the series products could support output capacitor range from 3.3uF to 220uF and with an ESR range between 0.001Ω and 5Ω. SCT recommends selecting a X5R- or X7R-type 4.7uF~10uF ceramic capacitor with low ESR over temperature range to improve the load transient response.

When using large output capacitor with higher ESR resistor, for example 100uF output electrolytic capacitor with 1Ω ESR resistor in the application, SCT recommends adding extra 10uF low ESR output capacitor parallel connection with the large electrolytic capacitor, this will eliminate the undershoot/overshoot voltage caused by the large ESR resistor and get better load transient performance.

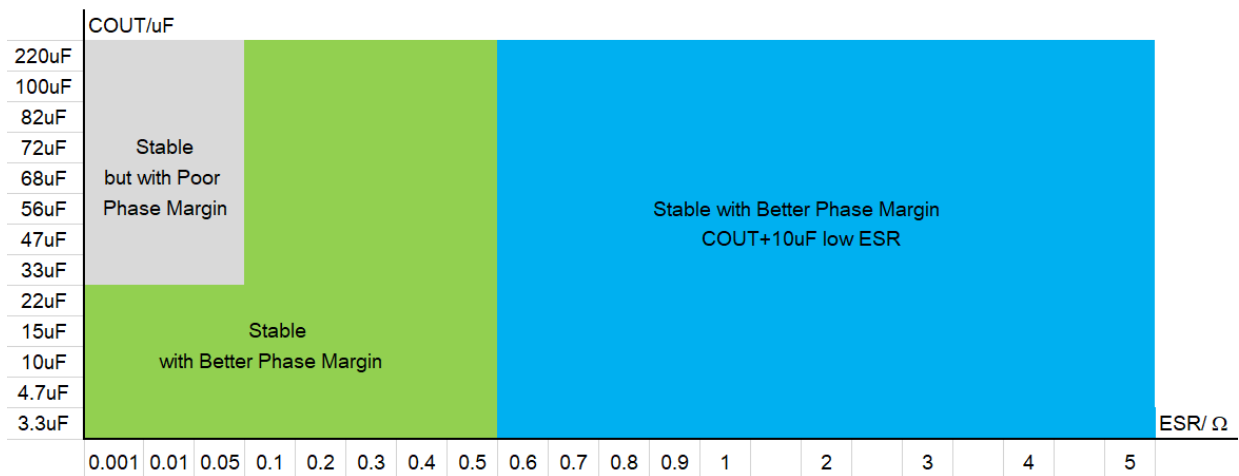

Figure 29. SCT71403Q Stability vs Output Capacitor

Power Dissipation and Thermal Performance

Power dissipation caused by voltage drop across the LDO and by the output current flowing through the device needs to be dissipated out from the chip. The maximum junction temperature is dependent on power dissipation, package, the PCB layout, number of used Cu layers, Cu layers thickness and the ambient temperature.

During normal operation, LDO junction temperature should not exceed 150°C, or else it may result in deterioration of the properties of the chip. Using below equations to calculate the power dissipation and estimate the junction temperature.

The power dissipation can be calculated using Equation 4. Because $I_{GND} \ll I_{OUT}$, the term $V_{IN} \times I_{GND}$ in Equation 4 could be ignored.

$$P_D = (V_{IN} - V_{OUT}) \times I_{OUT} + V_{IN} \times I_{GND} \quad (4)$$

The junction temperature can be estimated using Equation 5. $R_{\theta JA_EVM}$ is the junction-to-ambient thermal resistance based on customer's PCB. Verify the application and allow sufficient margins in the thermal design by the following method is used to calculate the junction temperature T_J .

$$T_J = T_A + P_D \times R_{\theta JA_EVM} \quad (5)$$

$R_{\theta JA_EVM}$ is a critical parameter and depends on many factors such as the following:

- Power dissipation
- Air temperature/flow
- PCB area
- Copper heat-sink area
- Number of thermal vias under the package
- Adjacent component placement

For the SCT71403Q series products, the maximum allowable power dissipation of different packages was listed in the following table, and the test results are based on our EVM board, larger power dissipation will trigger thermal shutdown protection. As a result, we could calculate the $R_{\theta JA_EVM}$ of different packages. The following table is just for your reference based on our EVM test, please leave enough margin when you design thermal performance.

The PCB information of our EVM: 2-layer, 1 oz Cu, 50mm x 30mm size.

Thermal Performance of Different Packages Based on EVM Test

Package	Max Allowable PD (W) (Not Trigger TSD, VOUT=5V)	Max Allowable PD (W) (T _J ≤150°C)	R _{θJA_EVM} (°C/W)
TQFN2X2-6L	2.32	2.00	62.5
EMSOP-8L	2.83	2.44	51.2
SOT23-5L	1.25	1.08	115.4
TQFN3X3-8L	2.42	2.08	60
SOT223-4L	3.15	2.71	46

SCT71403Q Series

THERMAL CHARACTERISTICS

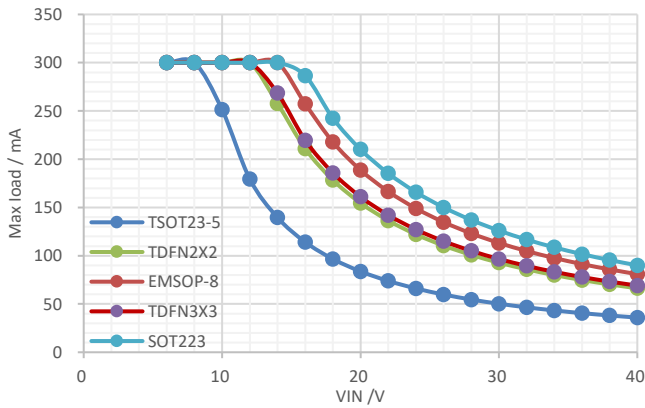

Figure 30. Maximum Output Current vs Input Voltage, VOUT=5V of Different Packages, $T_J \leq T_{SD_R}$

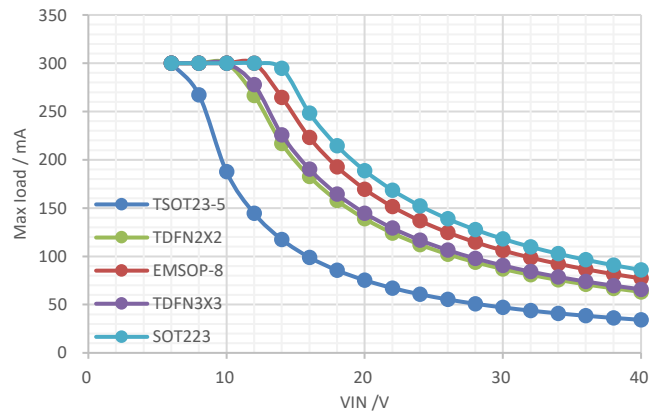

Figure 31. Maximum Output Current vs Input Voltage, VOUT=3.3V of Different Packages, $T_J \leq T_{SD_R}$

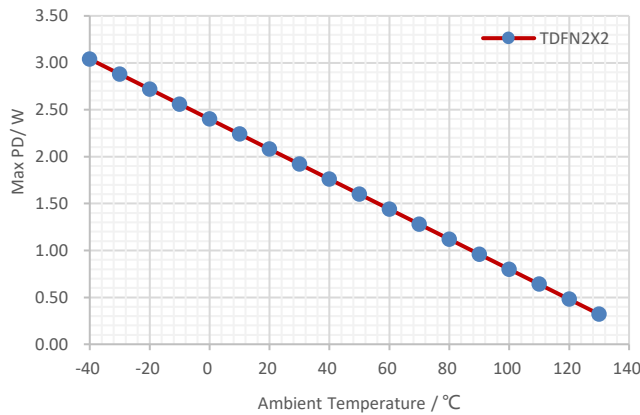

Figure 32. Maximum Allowed Power Dissipation vs Ambient Temperature, DFN2X2, $T_J \leq 150^\circ\text{C}$

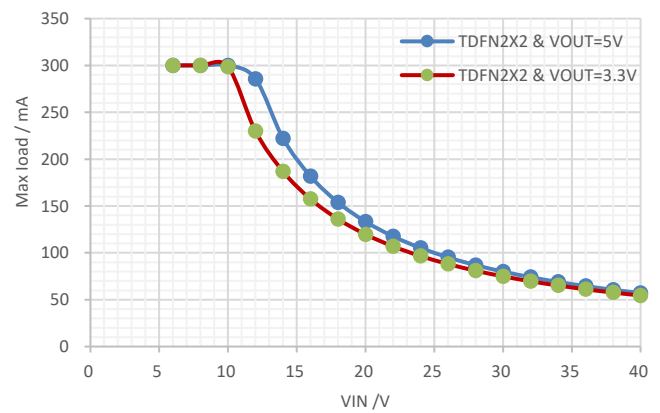

Figure 33. Maximum Output Current vs Input Voltage, DFN2X2, $T_J \leq 150^\circ\text{C}$

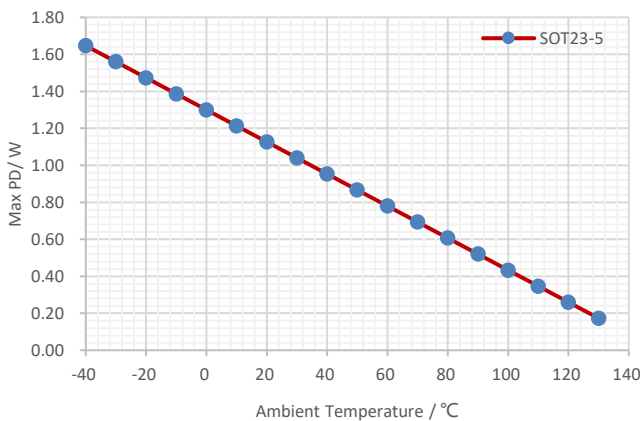

Figure 34. Maximum Allowed Power Dissipation vs Ambient Temperature, SOT23-5L, $T_J \leq 150^\circ\text{C}$

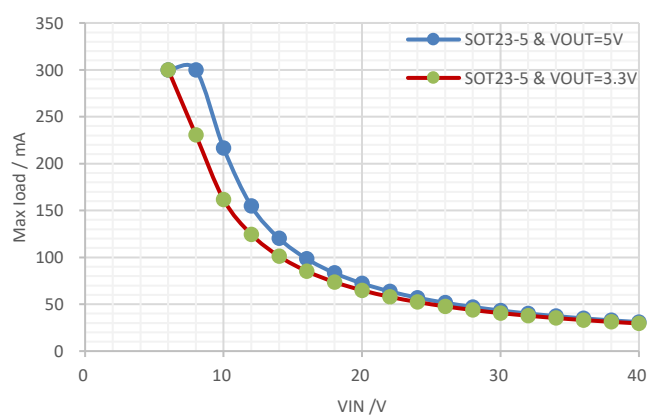

Figure 35. Maximum Output Current vs Input Voltage, SOT23-5L, $T_J \leq 150^\circ\text{C}$

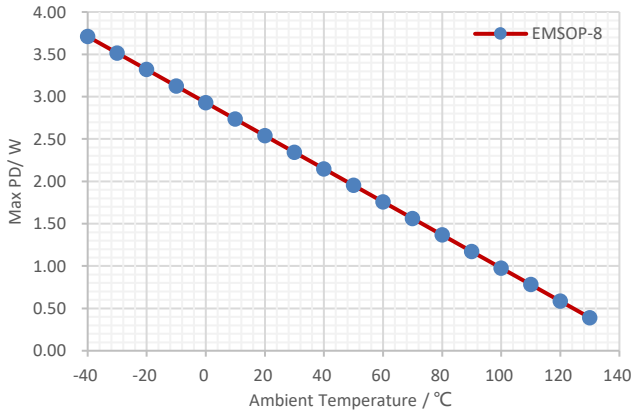

Figure 36. Maximum Allowed Power Dissipation vs Ambient Temperature, EMSOP-8L, $T_J \leq 150^\circ\text{C}$

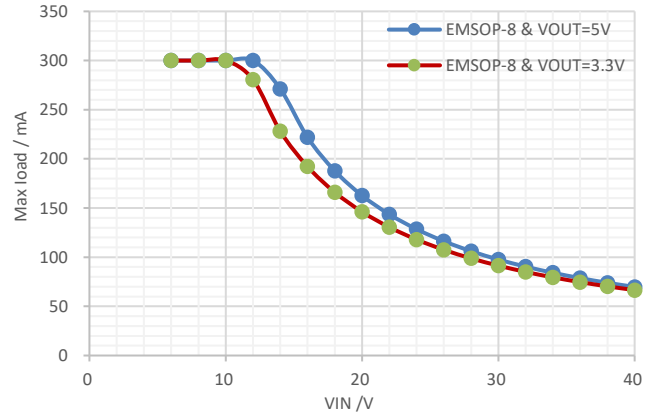

Figure 37. Maximum Output Current vs Input Voltage, EMSOP-8L, $T_J \leq 150^\circ\text{C}$

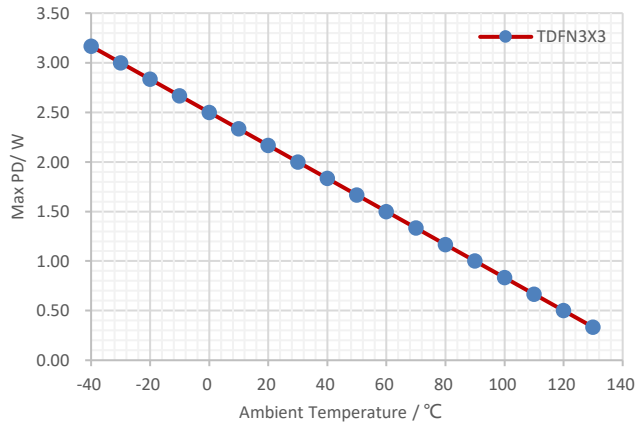

Figure 38. Maximum Allowed Power Dissipation vs Ambient Temperature, TQFN3X3-8L, $T_J \leq 150^\circ\text{C}$

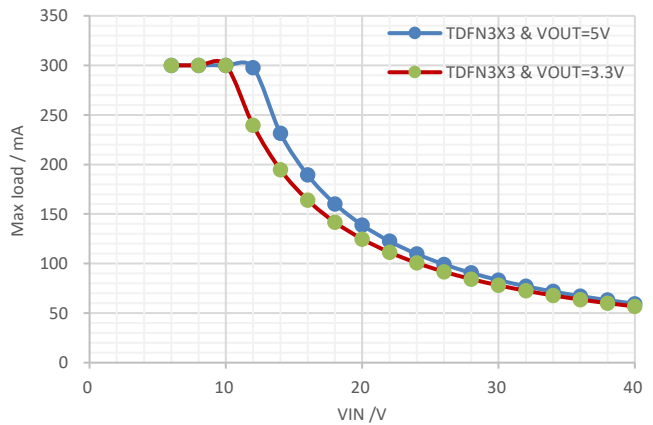

Figure 39. Maximum Output Current vs Input Voltage, TQFN3X3-8L, $T_J \leq 150^\circ\text{C}$

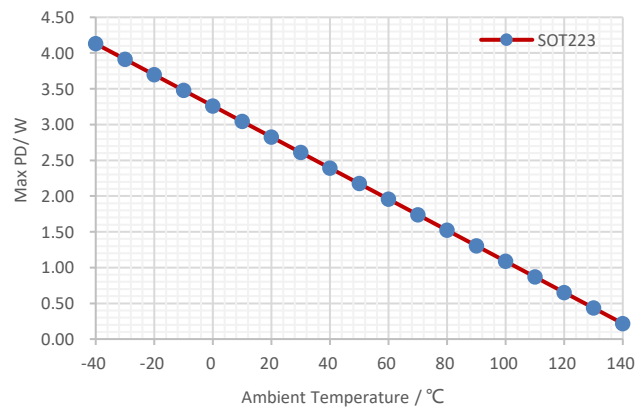

Figure 40. Maximum Allowed Power Dissipation vs Ambient Temperature, SOT223-4L, $T_J \leq 150^\circ\text{C}$

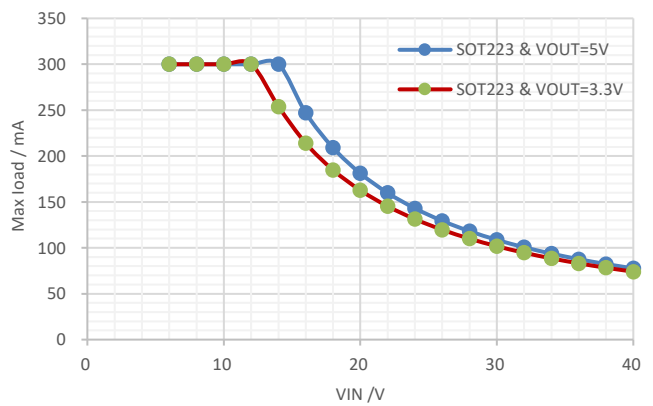

Figure 41. Maximum Output Current vs Input Voltage, SOT223-4L, $T_J \leq 150^\circ\text{C}$

SCT71403Q Series

Application Waveforms

Vin=Vout +1V, unless otherwise noted

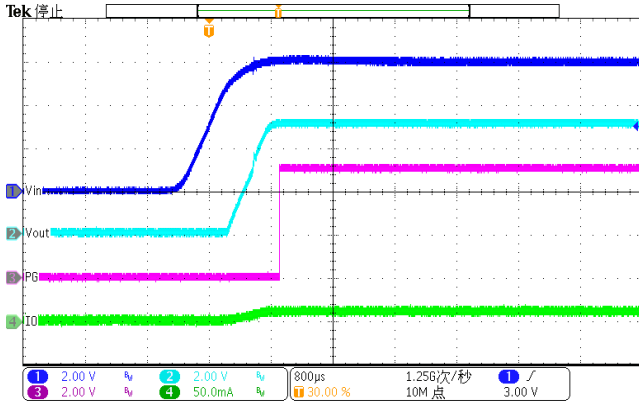

Figure 42. Power up (Iload=10mA)

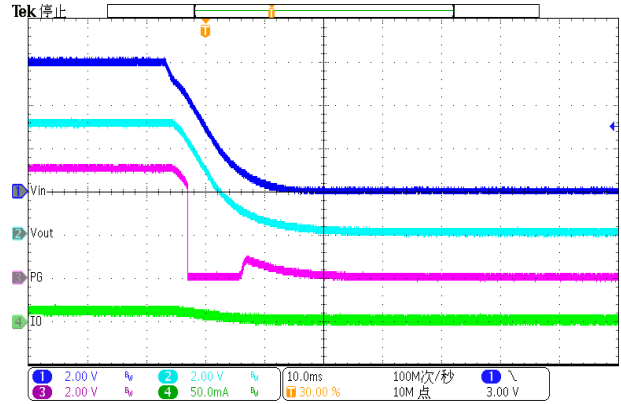

Figure 43. Power down (Iload=10mA)

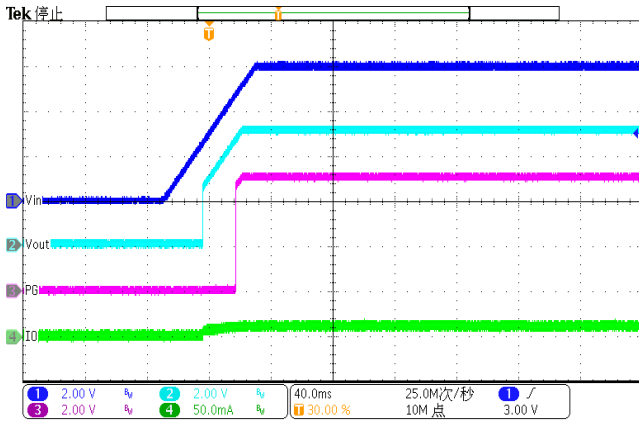

Figure 44 Slow Power up (Iload=10mA)

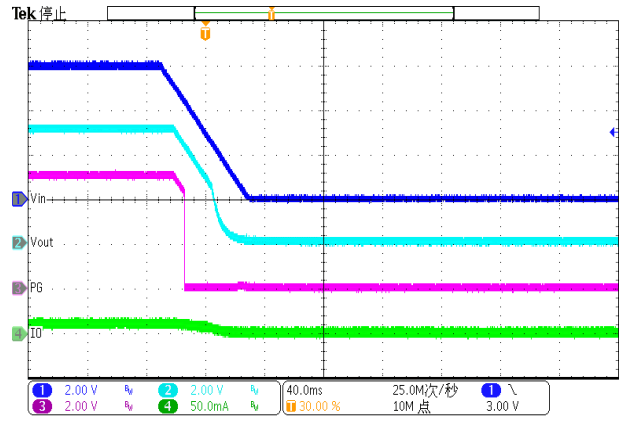

Figure 45. Slow Power down (Iload=10mA)

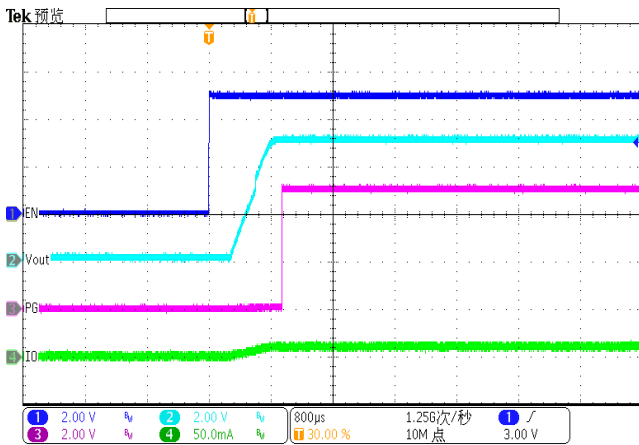

Figure 46. Enable (Iload=10mA)

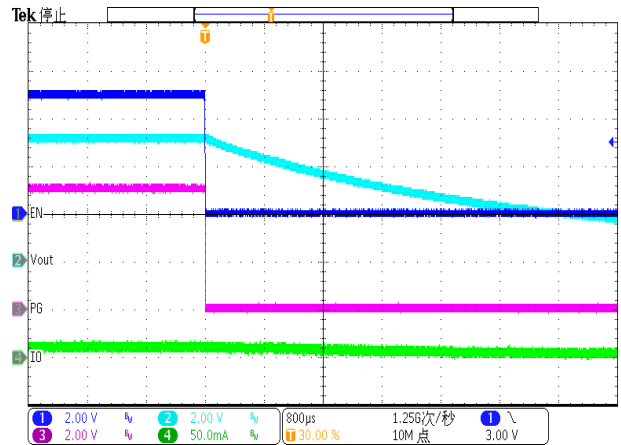

Figure 47. Disable (Iload=10mA)

Application Waveforms(Continued)

$V_{in}=V_{out} + 1V$, unless otherwise noted

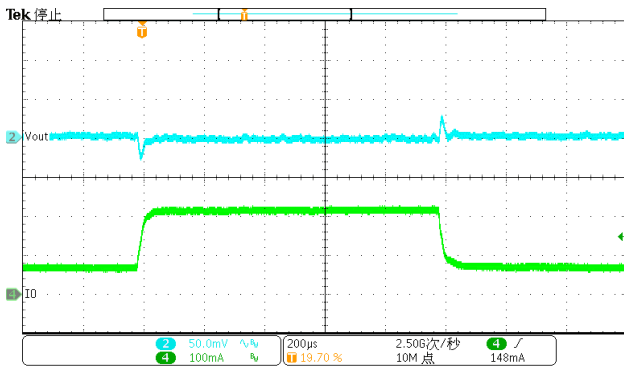

Figure 48. DC-DC Load Transient
(75mA-225mA), $V_{OUT}=5V$

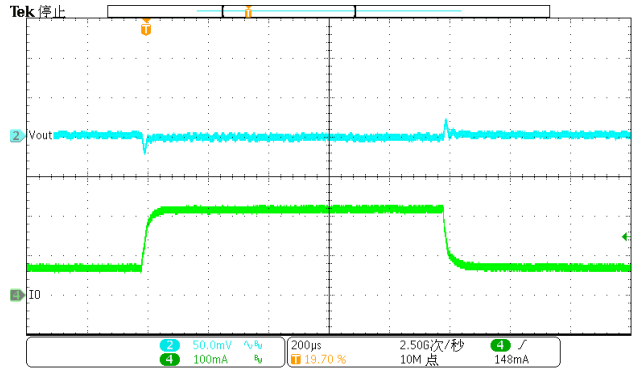

Figure 49. DC-DC Load Transient
(75mA-225mA), $V_{OUT}=3.3V$

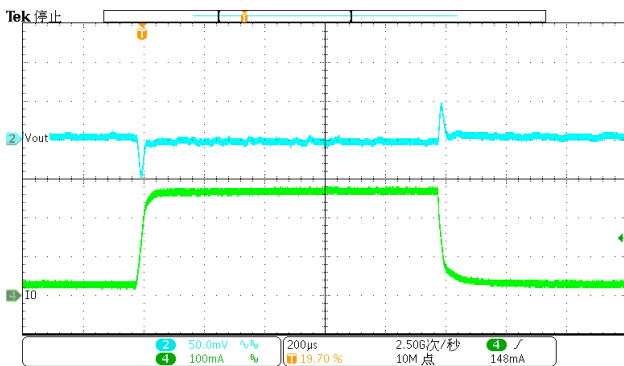

Figure 50. DC-DC Load Transient
(30mA-270mA), $V_{OUT}=5V$

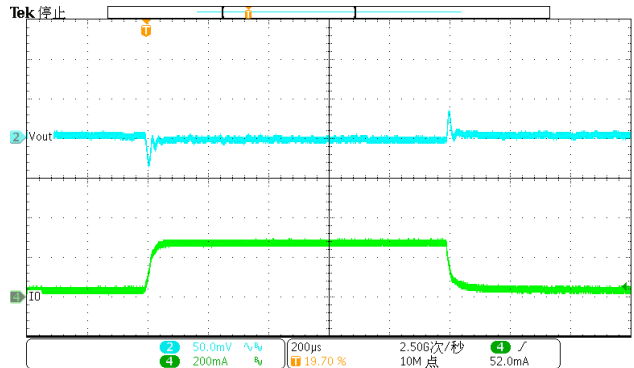

Figure 51. DC-DC Load Transient
(30mA-270mA), $V_{OUT}=3.3V$

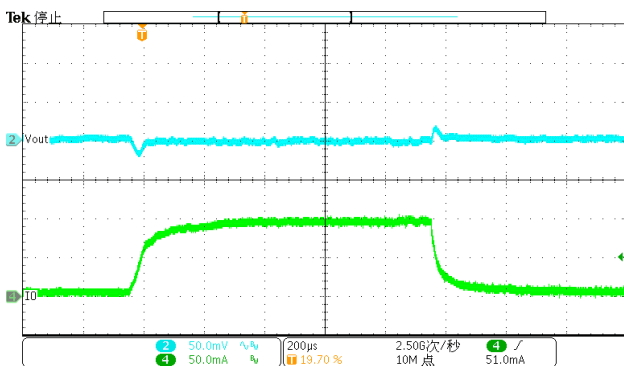

Figure 52. DC-DC Load Transient
(1mA-100mA), $V_{OUT}=5V$

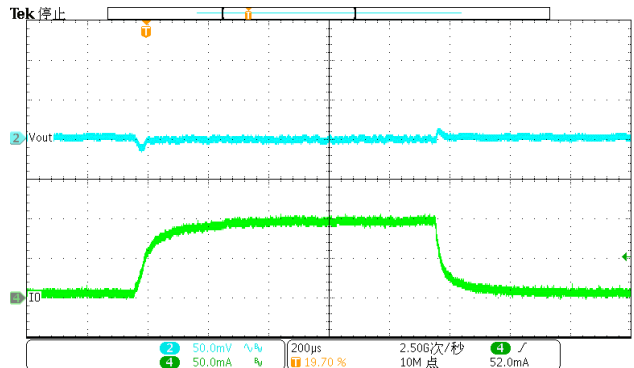

Figure 53. DC-DC Load Transient
(1mA-100mA), $V_{OUT}=3.3V$

SCT71403Q Series

Application Waveforms(Continued)

$V_{in} = V_{out} + 1V$, unless otherwise noted

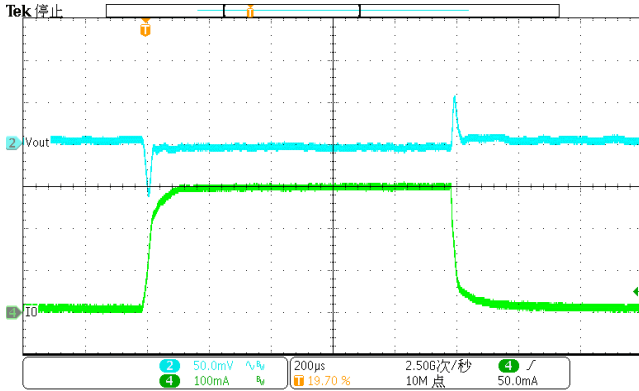

Figure 54. DC-DC Load Transient
(1mA-300mA) ,VOUT=5V

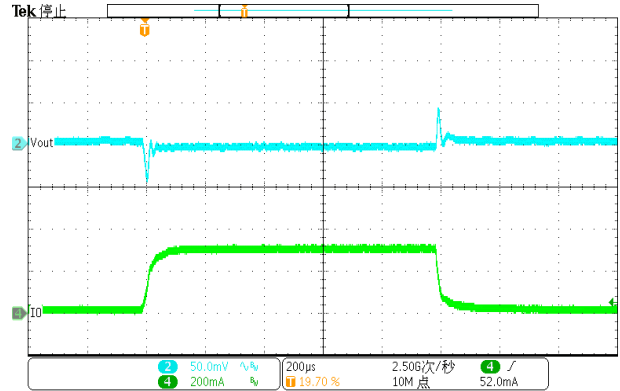

Figure 55. DC-DC Load Transient
(1mA-300mA) ,VOUT=3.3V

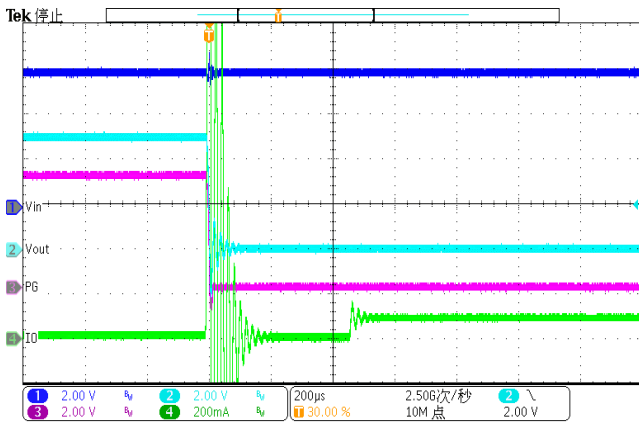

Figure 56. Enter Short Circuit Protection

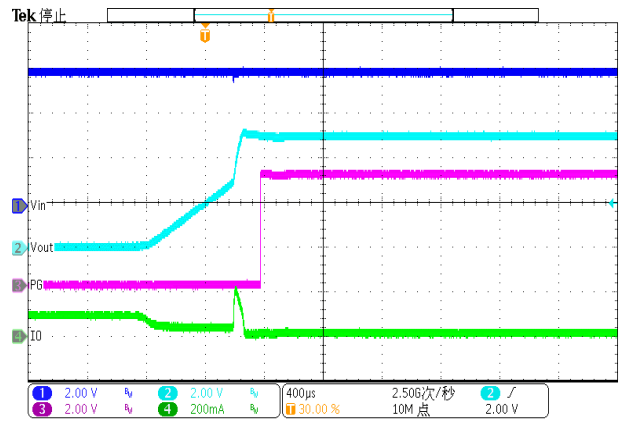

Figure 57. Exit Short Circuit Protection

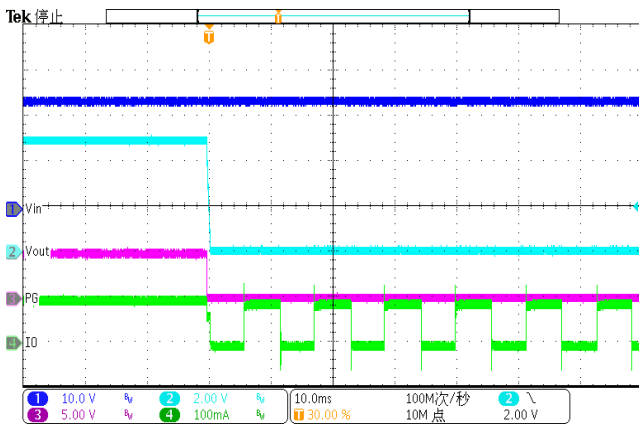

Figure 58. Enter Over Temperature Protection

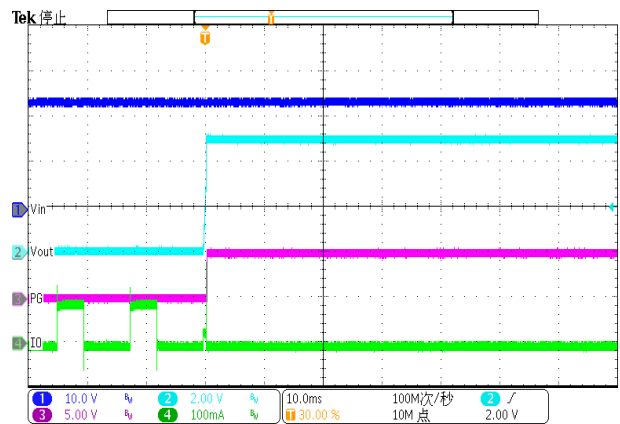

Figure 59. Exit Over Temperature Protection

Layout Guideline

Proper PCB layout is a critical for SCT71403Q's stability, transient performance and good regulation characteristics. For better results, follow these guidelines as below:

1. Both input capacitors and output capacitors must be placed as close to the device pins as possible.
2. It is recommended to bypass the input pin to ground with a 0.1μF bypass capacitor. The loop area formed by the bypass capacitor connection, V_{IN} pin and the GND pin of the system must be as small as possible.
3. It is recommended to use wide trace lengths or thick copper weight to minimize I×R drop and heat dissipation.
4. To improve the thermal performance of the device, and maximize the current output at high ambient temperature, SCT recommends spreading the copper under the thermal pad as far as possible and placing enough thermal vias on the copper under the thermal pad.
5. If using large electrolytic capacitor with high ESR resistor, SCT recommends adding a 10uF low ESR capacitor parallel connection with the large electrolytic capacitor.

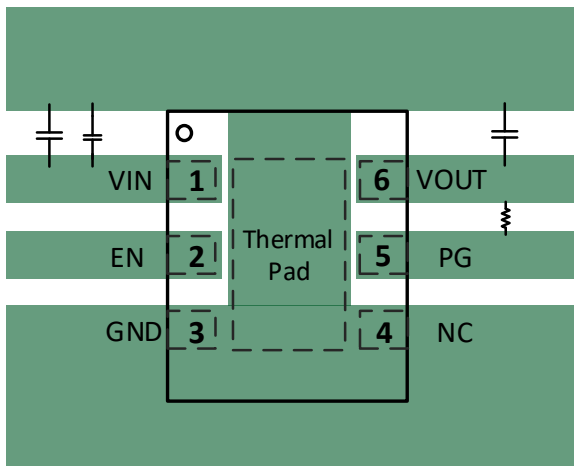

Figure 60. PCB Layout Example

SCT71403FxxAQDVAR

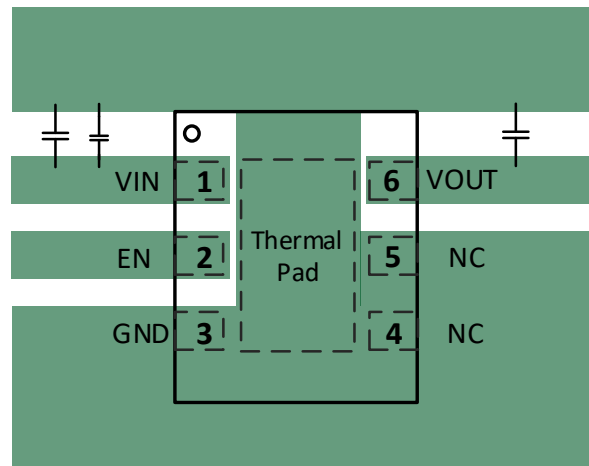

Figure 61. PCB Layout Example

SCT71403FxxQDVAR

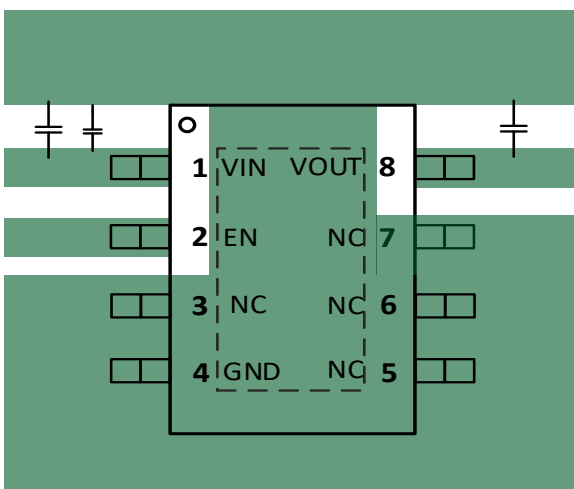

Figure 62. PCB Layout Example

SCT71403FxxQMTER

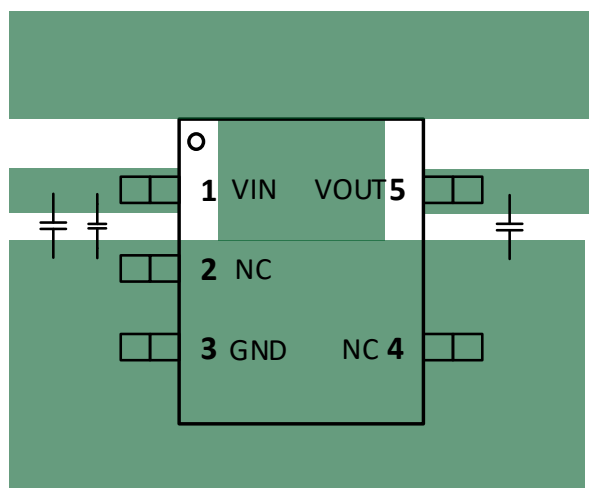

Figure 63. PCB Layout Example

SCT71403FxxQTWDR

SCT71403Q Series

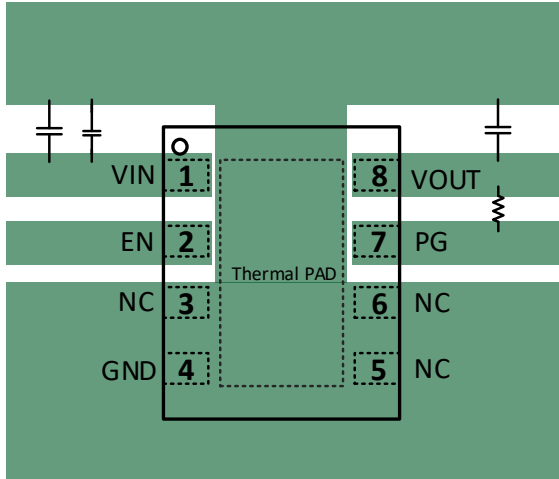

Figure 64. PCB Layout Example

SCT71403FxxQDTBR

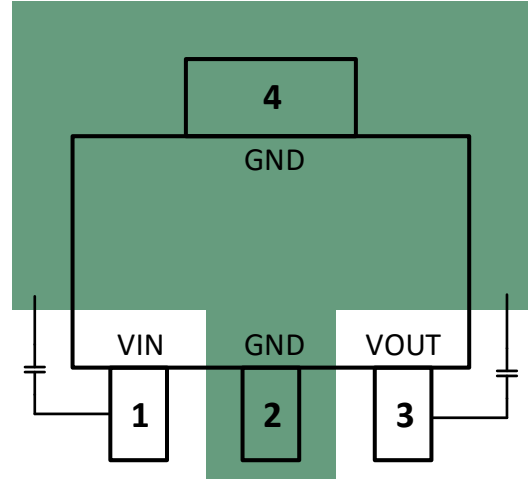
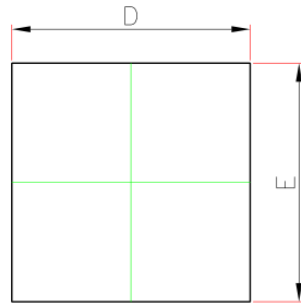

Figure 65. PCB Layout Example

SCT71403FxxQTXER

PACKAGE INFORMATION



TOP VIEW

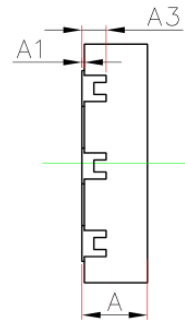

SIDE VIEW

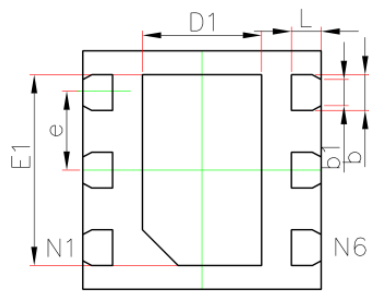

BOTTOM VIEW

TQFN2X2-6L Package Outline Dimensions

Symbol	Dimensions in Millimeters		Dimensions in Inches	
	Min.	Max.	Min.	Max.
A	0.700	0.800	0.028	0.031
A1	0.000	0.050	0.000	0.002
A3	0.203 REF.		0.008 REF.	
D	1.900	2.100	0.075	0.083
E	1.900	2.100	0.075	0.083
D1	0.900	1.100	0.035	0.043
E1	1.500	1.700	0.059	0.067
b	0.250	0.350	0.010	0.014
b1	0.220 REF.		0.009 REF.	
e	0.650 BSC.		0.026 BSC.	
L	0.174	0.326	0.007	0.013

NOTE:

1. Drawing proposed to be made a JEDEC package outline MO-220 variation.
2. Drawing not to scale.
3. All linear dimensions are in millimeters.
4. Thermal pad shall be soldered on the board.
5. Dimensions of exposed pad on bottom of package do not include mold flash.
6. Contact PCB board fabrication for minimum solder mask web tolerances between the pins.

SCT71403Q Series

PACKAGE INFORMATION

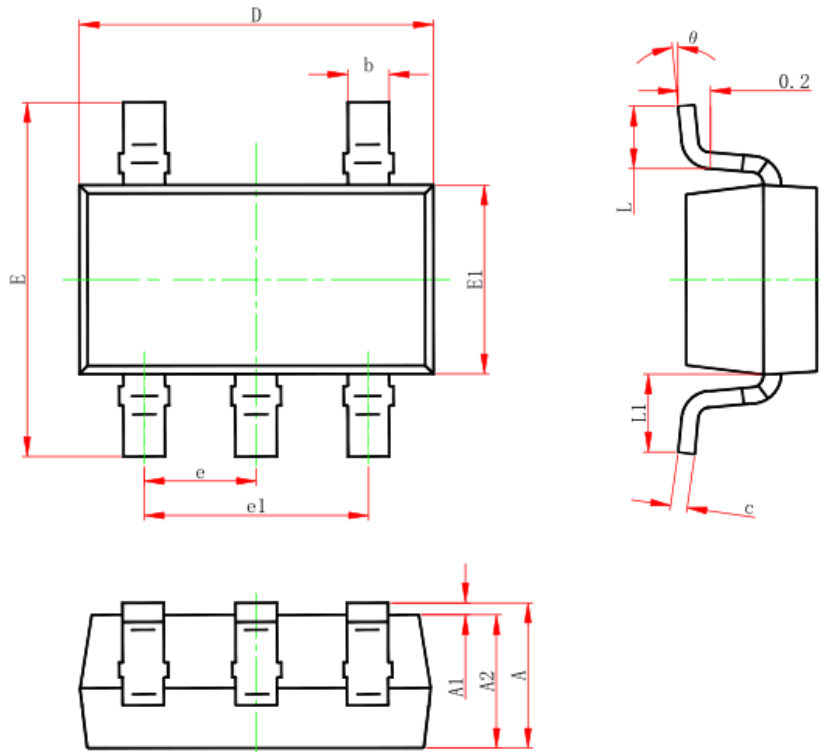

SOT23-5L Package Outline Dimensions

Symbol	Dimensions in Millimeters		Dimensions in Inches	
	Min.	Max.	Min.	Max.
A	1.050	1.250	0.041	0.049
A1	0.000	0.100	0.000	0.004
A2	1.050	1.150	0.041	0.045
b	0.300	0.500	0.012	0.020
c	0.100	0.200	0.004	0.008
D	2.820	3.020	0.111	0.119
E1	1.500	1.700	0.059	0.067
E	2.650	2.950	0.104	0.116
e	0.950 (BSC)		0.037 (BSC)	
e1	1.800	2.000	0.071	0.079
L	0.300	0.600	0.012	0.024
L1	0.600 REF		0.024 REF	
θ	0°	8°	0°	8°

NOTE:

1. Drawing proposed to be made a JEDEC package outline MO-220 variation.
2. Drawing not to scale.
3. All linear dimensions are in millimeters.
4. Thermal pad shall be soldered on the board.
5. Dimensions of exposed pad on bottom of package do not include mold flash.
6. Contact PCB board fabrication for minimum solder mask web tolerances between the pins.

PACKAGE INFORMATION

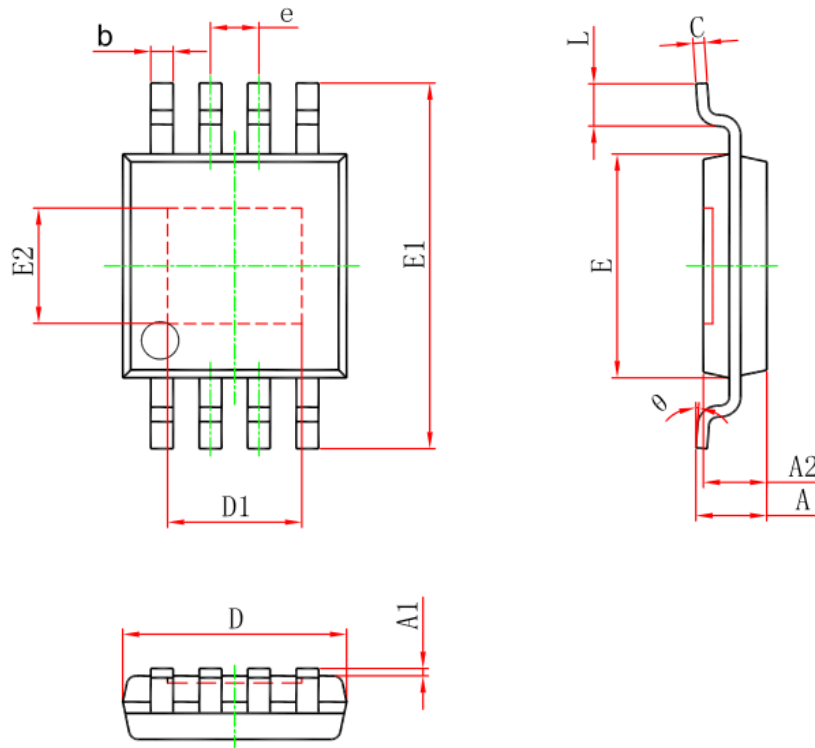

EMSOP-8L Package Outline Dimensions

Symbol	Dimensions in Millimeters		Dimensions in Inches	
	Min.	Max.	Min.	Max.
A	0.820	1.100	0.032	0.043
A1	0.020	0.150	0.001	0.006
A2	0.750	0.950	0.030	0.037
b	0.250	0.380	0.010	0.015
c	0.090	0.230	0.004	0.009
D	2.900	3.100	0.114	0.122
D1	1.700	1.900	0.067	0.075
e	0.65 (BSC)		0.026 (BSC)	
E	2.900	3.100	0.114	0.122
E1	4.750	5.050	0.187	0.199
E2	1.450	1.650	0.057	0.065
L	0.400	0.800	0.016	0.031
θ	0°	0°	0°	6°

NOTE:

1. Drawing proposed to be made a JEDEC package outline MO-220 variation.
2. Drawing not to scale.
3. All linear dimensions are in millimeters.
4. Thermal pad shall be soldered on the board.
5. Dimensions of exposed pad on bottom of package do not include mold flash.
6. Contact PCB board fabrication for minimum solder mask web tolerances between the pins.

SCT71403Q Series

PACKAGE INFORMATION

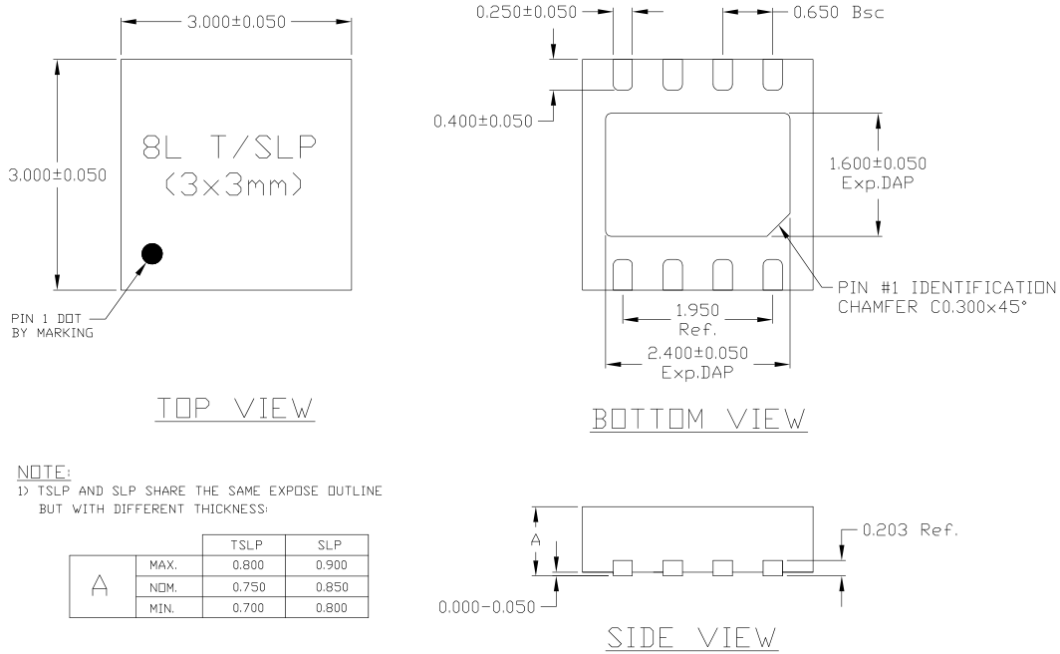

TQFN3X3-8L Package Outline Dimensions

NOTE:

1. Drawing proposed to be made a JEDEC package outline MO-220 variation.
2. Drawing not to scale.
3. All linear dimensions are in millimeters.
4. Thermal pad shall be soldered on the board.
5. Dimensions of exposed pad on bottom of package do not include mold flash.
6. Contact PCB board fabrication for minimum solder mask web tolerances between the pins.

PACKAGE INFORMATION

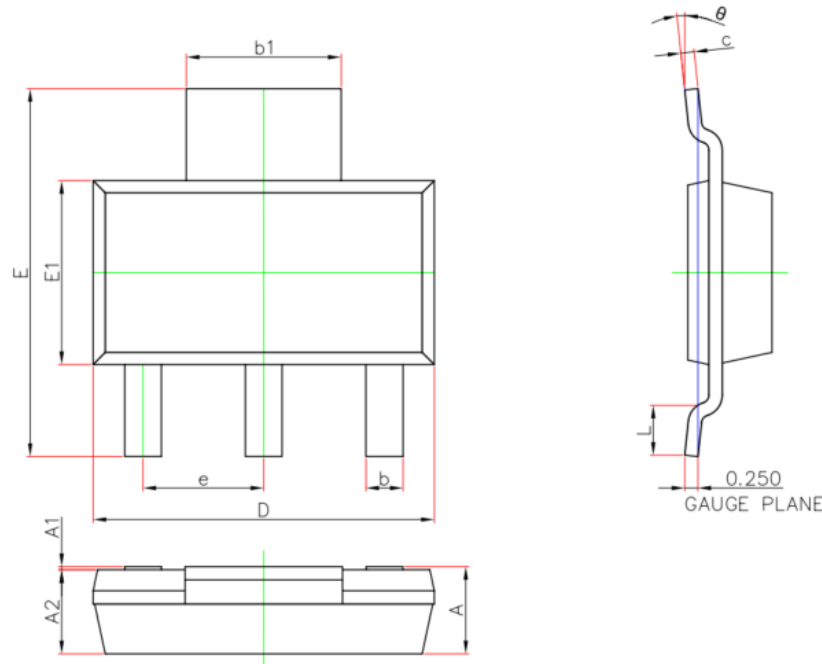

SOT223-4L Package Outline Dimensions

Symbol	Dimensions in Millimeters		Dimensions in Inches	
	Min.	Max.	Min.	Max.
A	--	1.800	--	0.071
A1	0.020	0.100	0.001	0.004
A2	1.500	1.700	0.059	0.067
b	0.660	0.840	0.026	0.033
b1	2.900	3.100	0.114	0.122
c	0.230	0.350	0.009	0.014
D	6.300	6.700	0.248	0.264
E	6.700	7.300	0.264	0.287
E1	3.300	3.700	0.130	0.146
e	2.300 (BSC)		0.091 (BSC)	
L	0.750	--	0.030	--
θ	0°	10°	0°	10°

NOTE:

7. Drawing proposed to be made a JEDEC package outline MO-220 variation.
8. Drawing not to scale.
9. All linear dimensions are in millimeters.
10. Thermal pad shall be soldered on the board.
11. Dimensions of exposed pad on bottom of package do not include mold flash.
12. Contact PCB board fabrication for minimum solder mask web tolerances between the pins.

SCT71403Q Series

TAPE AND REEL INFORMATION

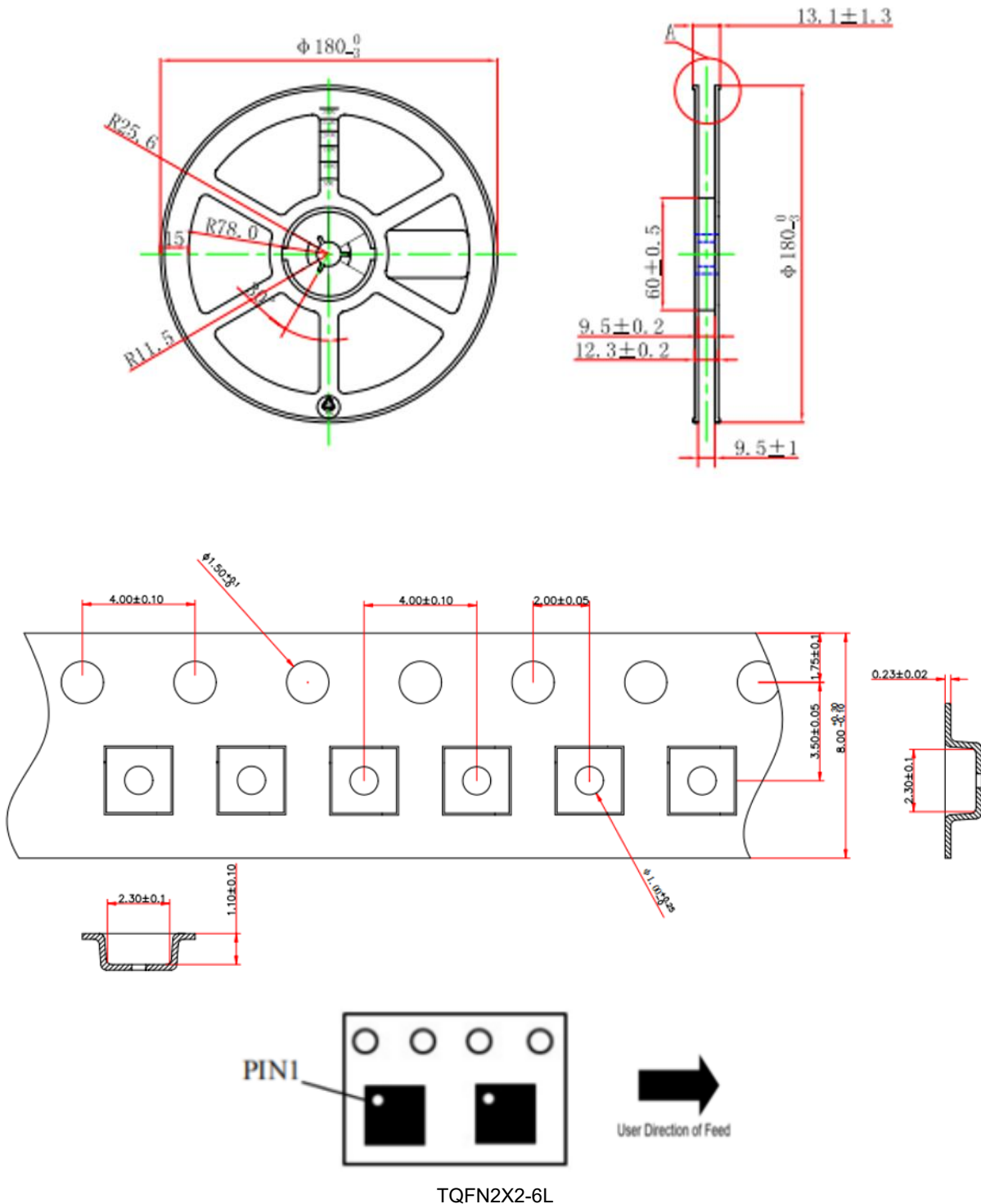

TQFN2X2-6L

NOTICE: The information in this document is subject to change without notice. Users should warrant and guarantee the third party Intellectual Property rights are not infringed upon when integrating Silicon Content Technology (SCT) products into any application. SCT will not assume any legal responsibility for any said applications.

TAPE AND REEL INFORMATION

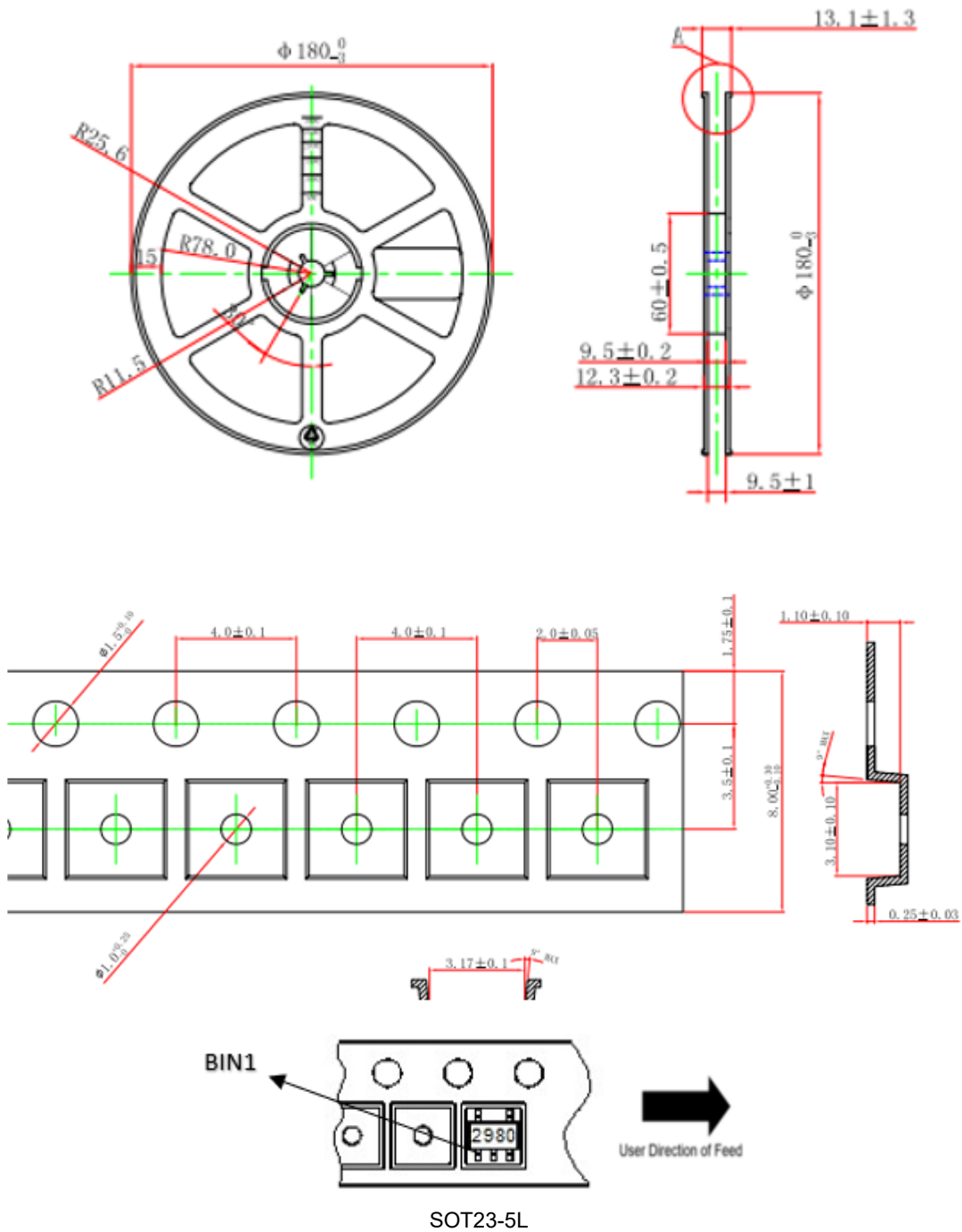

SOT23-5L

NOTICE: The information in this document is subject to change without notice. Users should warrant and guarantee the third party Intellectual Property rights are not infringed upon when integrating Silicon Content Technology (SCT) products into any application. SCT will not assume any legal responsibility for any said applications.

SCT71403Q Series

TAPE AND REEL INFORMATION

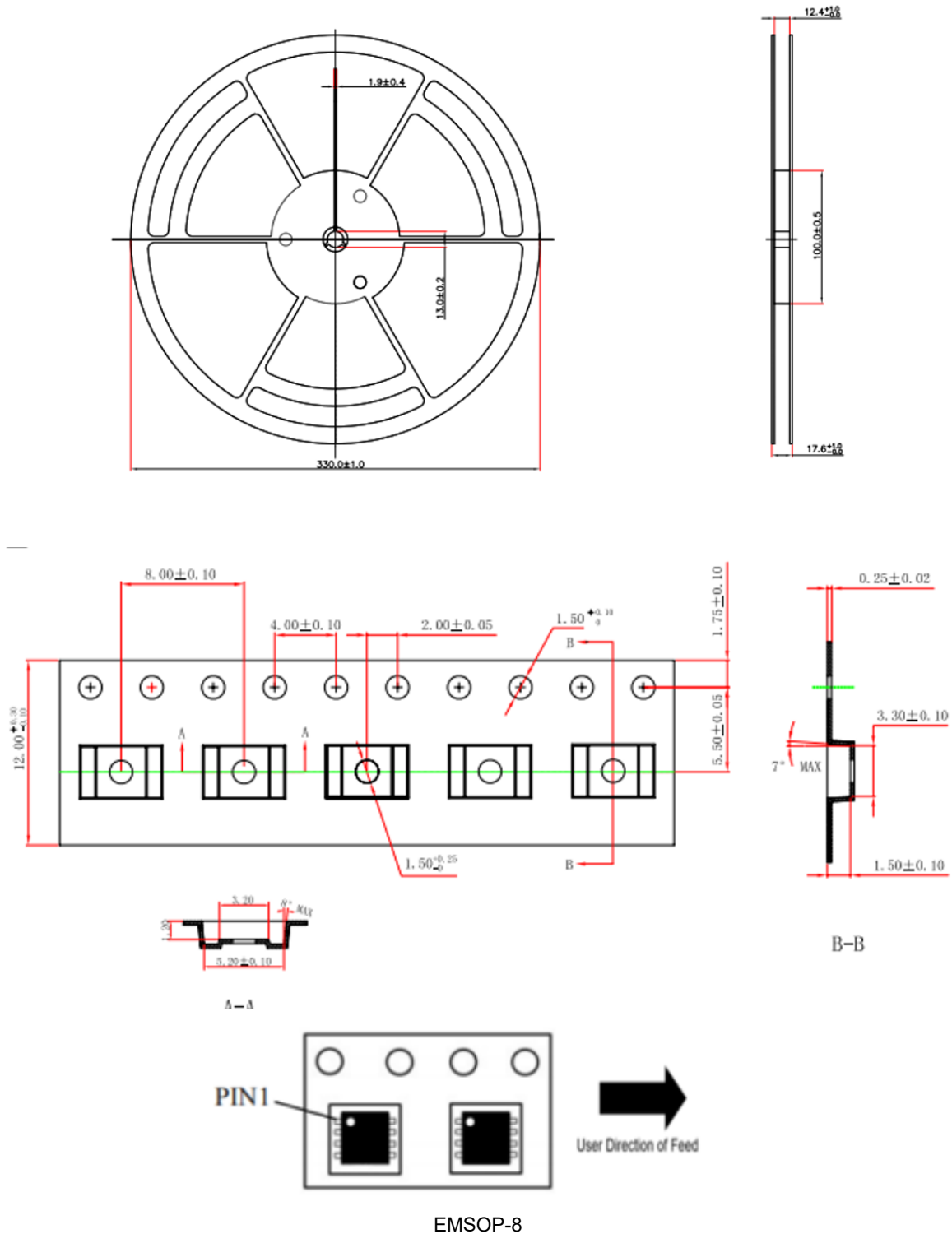

NOTICE: The information in this document is subject to change without notice. Users should warrant and guarantee the third party Intellectual Property rights are not infringed upon when integrating Silicon Content Technology (SCT) products into any application. SCT will not assume any legal responsibility for any said applications.

SCT71403Q Series

TAPE AND REEL INFORMATION

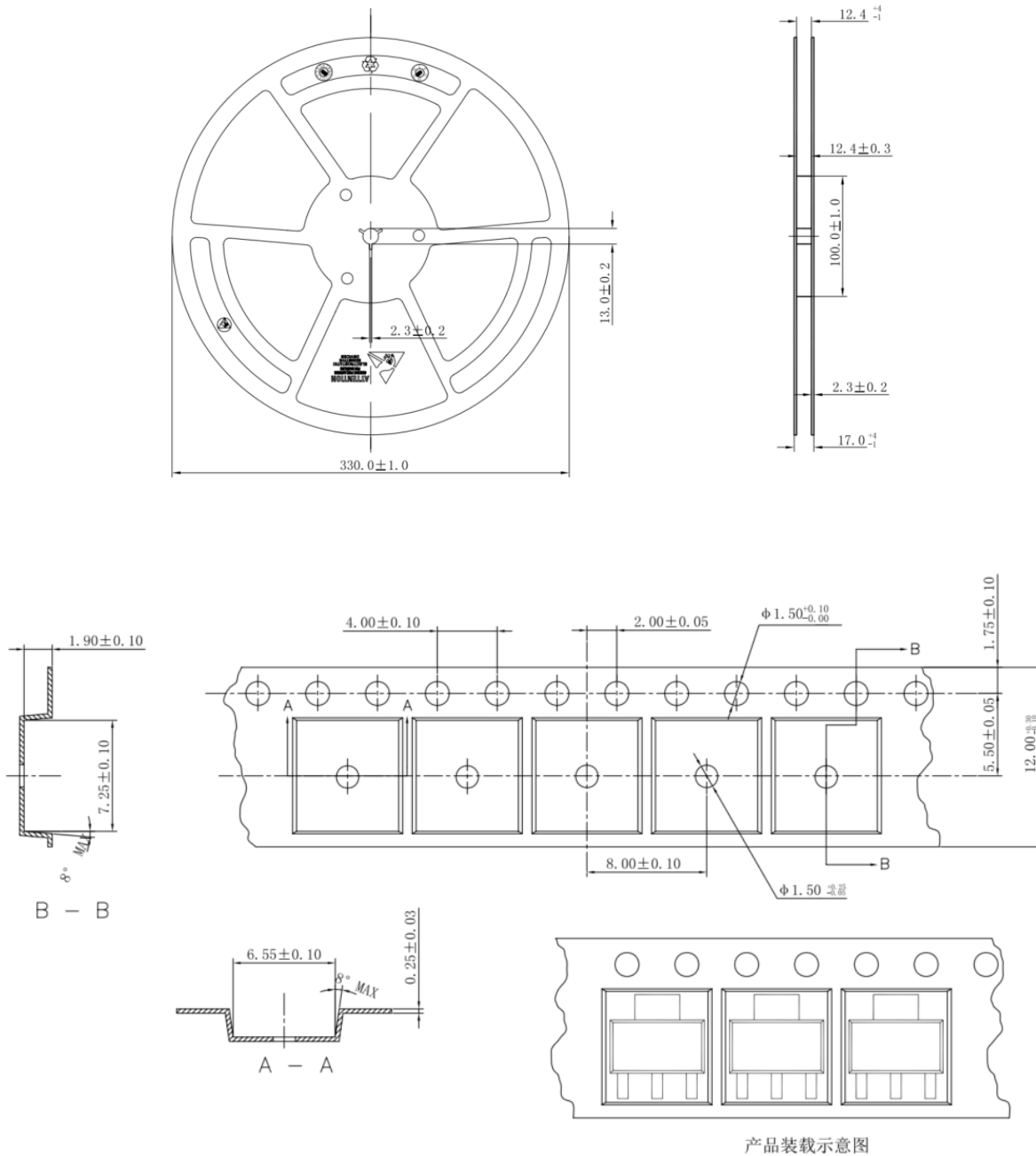

SOT223-4L

NOTICE: The information in this document is subject to change without notice. Users should warrant and guarantee the third party Intellectual Property rights are not infringed upon when integrating Silicon Content Technology (SCT) products into any application. SCT will not assume any legal responsibility for any said applications.