

## 4.1-40V 75-mΩ Single-Channel Smart High-Side Switch

### FEATURES

- Single -Channel 75-mΩ Smart High-Side Switch With Full Diagnostics
  - A Version: Open-Drain Digital Output
  - B Version: Current Sense Analog Output
- Wide Operating Voltage: 4.1 V to 40 V
- High accurate current sense:  $\pm 15\%$  @ 500mA,  $\pm 30\%$  @ 50mA with B Version
- Adjustable current limit:  $\pm 30\%$  when  $> 250\text{mA}$ ,  $\pm 15\%$  when  $> 500\text{mA}$
- Protection:
  - Short-to-GND Protection by Current Limit (Internal or External)
  - Thermal Shutdown With Thermal Swing
  - Inductive Load Negative Voltage Clamp with Optimized Slew Rate
  - Loss-of-GND and Loss-of-Battery Protection
- Diagnostic:
  - Overcurrent and Short-to-Ground Detection
  - Open Load / Short to Battery Detection During On and Off State
  - Global Fault Report for Fast Hardware Interrupt
- Available in an ETSSOP-14 Package

### APPLICATIONS

- High-Side Relay Drivers
- Power Switch for Sub-Module Power Supply
- Low Wattage Lamp Power Switch
- General Resistive, Inductive, and Capacitive Loads

### DESCRIPTION

The SCT41080 device is fully protected single-channel smart high-side switch with integrated 75-mΩ NMOS power FETs.

For version A, the device implements the digital fault report with an open-drain structure.

For version B, the device achieves high-precision current detection, making diagnosis more accurate.

The SCT41080 provides current limit, thermal shutdown protection. Full diagnostics and high-accuracy current sense enable intelligent control of the load. The device is available in a 14-pin ETSSOP-14 package.

### TYPICAL APPLICATION

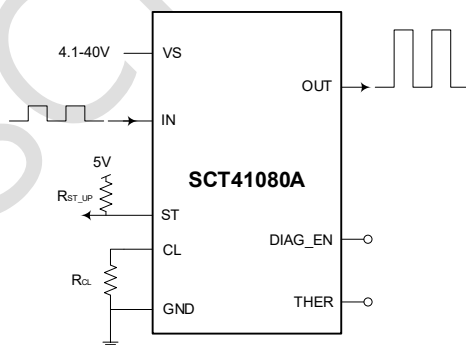

Typical Application of Version A

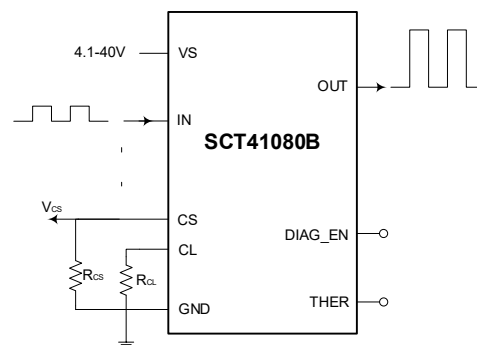

Typical Application of Version B

# SCT41080

## REVISION HISTORY

Revision 0.8: Customer Sample

Revision 0.81: Update Package name

Revision 0.82: Update Device Order Information

Revision 0.83: Update EC Table

## DEVICE ORDER INFORMATION

| ORDERABLE DEVICE | PACKAGING TYPE | STANDARD PACK QTY | PACKAGE MARKING | PINS | PACKAGE DESCRIPTION |
|------------------|----------------|-------------------|-----------------|------|---------------------|
| SCT41080AMNER    | Tape & Reel    | 4000              | 080A            | 14   | ETSSOP-14           |
| SCT41080BMNER    | Tape & Reel    | 4000              | 080B            | 14   | ETSSOP-14           |

## ABSOLUTE MAXIMUM RATINGS

Over operating free-air temperature unless otherwise noted<sup>(1)</sup>

| DESCRIPTION  | MIN   | MAX | UNIT |
|--|-------|-----|------|
| VS (t < 400 mS)  | -0.3  | 43  | V    |
| OUT (t < 400 mS)   | -0.3  | 43  | V    |
| Reverse polarity voltage <sup>(2)</sup>                    | -18   |     | V    |
| Current on GND (t < 2 minutes)                             | -250  | 20  | mA   |
| Voltage on IN, DIAG_EN                                     | -0.3  | 5   | V    |
| Current on IN, DIAG_EN                                     | -10   |     | mA   |
| Voltage on ST  | -0.3  | 5   | V    |
| Current on ST  | -30   | 10  | mA   |
| Voltage on CS  | --2.7 | 5   | V    |
| Current on CS  |       | 30  | mA   |
| Voltage on CL  | -0.3  | 5   | V    |
| Current on CL  |       | 6   | mA   |
| Inductive load switch-off energy dissipation, single pulse |       | 70  | mJ   |
| Operating ambient temperature                              | -40   | 125 | °C   |
| Operating Junction temperature <sup>(3)</sup>              | -40   | 150 | °C   |
| Storage temperature T <sub>STG</sub>                       | -65   | 150 | °C   |

**PIN CONFIGURATION**

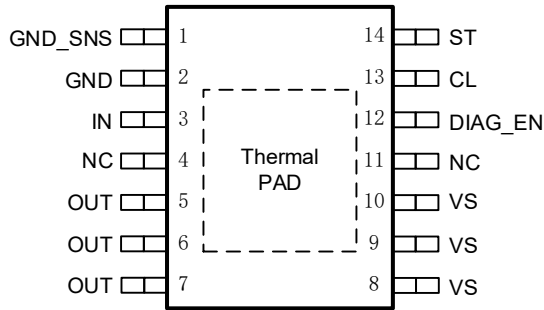

Top View: Version A ETSSOP-14

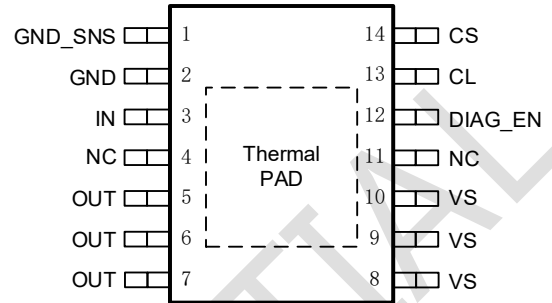

Top View: Version B ETSSOP-14

- (1) Stresses beyond those listed under Absolute Maximum Rating may cause device permanent damage. The device is not guaranteed to function outside of its Recommended Operation Conditions.
- (2) Reverse polarity condition:  $t < 60$  s, reverse current  $< I_{rev1}$ , GND pin 1-k $\Omega$  resistor in parallel with diode
- (3) The IC includes thermal shutdown protection to protect the device during overload conditions. Junction temperature will exceed 170°C when thermal shutdown protection is active. Continuous operation above the specified maximum operating junction temperature will reduce lifetime.

# SCT41080

## PIN FUNCTIONS

| NAME    | NO.       |           | I/O <sup>(1)</sup> | PIN FUNCTION  |
|---------|-----------|-----------|--------------------|---|
|         | A Version | B Version |                    |   |
| GND_SNS | 1         | 1         | I                  | External ground sense.  |
| GND     | 2         | 2         | G                  | IC ground pin.  |
| IN      | 3         | 3         | I                  | logic input, internal pulldown.   |
| NC      | 4,11      | 4,11      | -                  | Not Connection.   |
| OUT     | 5,6,7     | 5,6,7     | O                  | Output of high side-switch, connected to the load.                      |
| VS      | 8,9,10    | 8,9,10    | I                  | Power supply; battery voltage.  |
| DIAG_EN | 12        | 12        | I                  | Enable-disable pin for diagnostics; internal pulldown.                  |
| CL      | 13        | 13        | I                  | Adjustable current limits.  |
| ST      | 14        | -         | O                  | Open-drain diagnostic status output, external pull-up voltage required. |
| CS      | -         | 14        | O                  | Current-sense output  |

(1) G=Ground, I=Input, O=Output

**RECOMMENDED OPERATING CONDITIONS**

Over operating free-air temperature range unless otherwise noted

| PARAMETER               | DEFINITION                     | MIN | MAX | UNIT |
|-------------------------|--------------------------------|-----|-----|------|
| V <sub>VS</sub>         | Input voltage range            | 4.1 | 40  | V    |
| IN, DIAG_EN             | External pull-up voltage range | 0   | 5   | V    |
| ST                      | External pull-up voltage range | 0   | 5   | V    |
| Nominal dc load current |                                | 0   | 4   | A    |
| T <sub>J</sub>          | Operating junction temperature | -40 | 150 | °C   |

**ESD RATINGS**

| PARAMETER        | DEFINITION   | MIN | MAX | UNIT |
|------------------|--|-----|-----|------|
| V <sub>ESD</sub> | Human Body Model(HBM), per ANSI-JEDEC-JS-001-2014 specification, all pins <sup>(1)</sup>     | -2  | +2  | kV   |
|                  | Charged Device Model(CDM), per ANSI-JEDEC-JS-002-2014 specification, all pins <sup>(2)</sup> | -1  | +1  | kV   |

(1) JEDEC document JEP155 states that 500V HBM allows safe manufacturing with a standard ESD control process.

(2) JEDEC document JEP157 states that 250V CDM allows safe manufacturing with a standard ESD control process.

## THERMAL INFORMATION

| PARAMETER              | THERMAL METRIC  | ETSSOP-14 | UNIT |
|------------------------|---|-----------|------|
| R <sub>θJA</sub>       | Junction to ambient thermal resistance <sup>(1)</sup>       | 35.85     | °C/W |
| R <sub>θJC (top)</sub> | Junction to case (top) thermal resistance <sup>(1)</sup>    | 48.58     |      |
| R <sub>θJC (bot)</sub> | Junction to case (bottom) thermal resistance <sup>(1)</sup> | 5.72      |      |
| R <sub>θJB</sub>       | Junction to board thermal resistance <sup>(1)</sup>         | 16.16     |      |
| R <sub>ψJT</sub>       | Junction-to-top characterization parameter                  | 4.49      |      |

(1) SCT provides R<sub>θJA</sub> and R<sub>θJC</sub> numbers only as reference to estimate junction temperatures of the devices. R<sub>θJA</sub> and R<sub>θJC</sub> are not a characteristic of package itself, but of many other system level characteristics such as the design and layout of the printed circuit board (PCB) on which the SCT41080 is mounted, thermal pad size, and external environmental factors. The PCB board is a heat sink that is soldered to the leads and thermal pad of the SCT41080. Changing the design or configuration of the PCB board changes the efficiency of the heat sink and therefore the actual R<sub>θJA</sub> and R<sub>θJC</sub>.

## ELECTRICAL CHARACTERISTICS

Typical values correspond to T<sub>J</sub> = 25°C. Minimum and maximum limits apply over the -40°C to 125°C junction temperature range unless otherwise stated. V<sub>S</sub> = 13.5 V, I<sub>N</sub> = 5 V unless otherwise stated.

| SYMBOL                 | PARAMETER                               | TEST CONDITION  | MIN | TYP | MAX | UNIT |
|------------------------|---|---|-----|-----|-----|------|
| <b>Power Supply</b>    |   |   |     |     |     |      |
| V <sub>VS</sub>        | Operating input voltage                 |   | 4.1 |     | 40  | V    |
| V <sub>VS_UVLO</sub>   | Input UVLO Threshold Hysteresis         | V <sub>VS</sub> rising  |     | 3.8 | 4   | V    |
| I <sub>Q_OP</sub>      | Operating input current                 | DIAG_EN=5V, I <sub>OUT</sub> =0.5A, Current limit=5A  |     | 2.3 |     | mA   |
|                        |   | DIAG_EN=5V, I <sub>OUT</sub> =0A, Current limit=5A  |     | 2   |     |      |
| I <sub>OFF</sub>       | Standby current                         | IN=DIAG_EN=0V, CL=CS=Floating   |     |     | 0.3 | uA   |
|                        |   | IN=DIAG_EN= 0V, CL=CS=Floating, T <sub>J</sub> =125°C   |     |     | 3   | uA   |
| I <sub>OFF(DIAG)</sub> | Standby current with diagnostic enabled | IN=0V, DIAG_EN=5V, VS-OUT>V <sub>OL_OFF</sub>   |     | 1   | 5   | mA   |
| t <sub>OFF(DIAG)</sub> | Standby mode deglitch time              | IN from high to low, if deglitch time >T <sub>OFF(DIAG)</sub> , the device enters into standby mode.            |     | 9   |     | mS   |
| I <sub>LKG_OUT</sub>   | Output leakage current in off-state     | IN=DIAG_EN=OUT=0V   |     |     | 3   | uA   |
| <b>Power Stage</b>     |   |   |     |     |     |      |
| R <sub>DSON</sub>      | On-state resistance                     |   |     | 75  |     | mΩ   |
| V <sub>F</sub>         | Drain-source diode voltage              | IN=0V, I <sub>OUT</sub> = -0.1 A  |     | 0.7 |     | V    |
| I <sub>CL(INT)</sub>   | Internal current limit                  | Internal current limit value, CL pin connected to GND   | 7   |     | 14  | A    |
| I <sub>CL(TSD)</sub>   | Current limit during thermal shutdown   | Internal current limit value under thermal shutdown   |     | 4.1 |     | A    |
|                        |   | External current limit value under thermal shutdown. The percentage of the external current limit setting value |     | 60% |     |      |
| V <sub>DS(clamp)</sub> | Drain-to-source internal clamp voltage  |   |     | 47V |     | V    |

## Logic Input(IN,DIAG\_EN)

|                        |                               |  |     |      |    |
|------------------------|-------------------------------|--|-----|------|----|
| V <sub>IH</sub>        | Logic high-level voltage      |  | 1.1 | 1.3  | V  |
| V <sub>IL</sub>        | Logic low-level voltage       |  | 0.6 | 0.95 | V  |
| R <sub>L_PG_IN</sub>   | IN-pin pulldown resistor      |  | 480 |      | kΩ |
| R <sub>L_PG_DIAG</sub> | DIAG_EN-pin pulldown resistor |  | 480 |      | kΩ |

## Diagnostics

|                      |  |   |     |     |     |    |
|----------------------|--|---|-----|-----|-----|----|
| I <sub>LKG_GL</sub>  | Output leakage current under GND loss condition                  |   | 14  | 100 | μA  |    |
| V <sub>OL_OFF</sub>  | Open-load detection threshold                                    | IN = 0 V, when V <sub>VS</sub> - V <sub>OUTx</sub> < V <sub>OL_OFF</sub> , duration longer than t <sub>(ol,off)</sub> , then open load is detected, off state | 1.1 | 1.7 | 2.4 | V  |
| t <sub>DOL_OFF</sub> | Open-load detection threshold deglitch time in off-state         |   | 30  |     |     | μS |
| I <sub>OL_OFF</sub>  | Off-state output sink current                                    | IN=0V,DIAG_EN=5V, V <sub>OUT</sub> =V <sub>VS</sub>   | 43  |     |     | μA |
| I <sub>OL_ONF</sub>  | Open-load detection threshold in on state, load from high to low | IN=5V, when I <sub>OUT</sub> < I <sub>OL_ON</sub> , duration longer than I <sub>OL_ONF/R</sub> . Open load detected. Version A only                           | 38  |     |     | mA |
| I <sub>OL_ONR</sub>  | Open-load detection threshold in on state, load from low to high |   | 68  |     |     | mA |
| t <sub>DOL_ON</sub>  | Open-load detection threshold deglitch time in on-state          |   | 700 |     |     | μS |
| V <sub>ST</sub>      | Status low-output voltage  | IST = 2 mA, version A only  | 0.3 |     |     | V  |
| t <sub>CL_DEG</sub>  | Deglitch time when current limit occurs                          | IN= DIAG_EN = 5V, the deglitch time from current limit toggling to ST, CS report.   |     | 70  |     | μS |
| T <sub>SD</sub>      | Thermal shutdown threshold                                       |   | 180 |     |     | °C |
| T <sub>SD_RST</sub>  | Thermal shutdown status reset threshold                          |   | 160 |     |     | °C |
| T <sub>SW</sub>      | Thermal swing shutdown threshold                                 |   | 40  |     |     | °C |
| T <sub>HYS</sub>     | Hysteresis for resetting the thermal shutdown or thermal swing   |   | 10  |     |     | °C |

## Current Limit

|                                    |                                  |  |          |          |   |
|------------------------------------|----------------------------------|--|----------|----------|---|
| K <sub>CL</sub>                    | Current-limit ratio              |  | 2000     |          |   |
| V <sub>CL</sub>                    | Current limit internal threshold |  | 1.233    |          | V |
| ΔK <sub>CL</sub> / K <sub>CL</sub> | External current limit accuracy  | I <sub>Limit</sub> ≥ 0.25A<br>1A ≤ I <sub>Limit</sub> ≤ 7A | 50<br>15 | 50<br>15 | % |

## Current Sense (Version B)

|                                    |                                    |  |                   |                           |   |
|------------------------------------|------------------------------------|--|-------------------|---------------------------|---|
| K <sub>CS</sub>                    | Current-sense ratio                |  | 500               |                           |   |
| ΔK <sub>CS</sub> / K <sub>CS</sub> |                                    | I <sub>OUTx</sub> ≥ 50mA<br>I <sub>OUTx</sub> ≥ 100mA<br>I <sub>OUTx</sub> ≥ 500mA | -30<br>-20<br>-15 | 30<br>20<br>15            |   |
| V <sub>CS_LIN</sub>                | Current-sense voltage linear range | V <sub>VS</sub> ≥ 6.5V<br>5V ≤ V <sub>VS</sub> < 6.5V                              | 0<br>0            | 4<br>V <sub>VS</sub> -2.5 | V |
| I <sub>OUT_LIN</sub>               | Output-current linear range        |  | 0                 | 3.5                       | A |

# SCT41080

|               |  |                                |     |     |         |
|---------------|--|--------------------------------|-----|-----|---------|
| $V_{CS\_H}$   | Current sense pin output voltage               | Fault mode                     | 4.3 | 5   | V       |
| $I_{CS\_H}$   | Current-sense pin output current               | $V_{CS}=4.3V$                  | 10  | 20  | mA      |
| $I_{CS\_LKG}$ | Current-sense leakage current in disabled mode | $DIAG\_EN=0V, T_J=125^\circ C$ |     | 0.5 | $\mu A$ |

## Switching

|                           |  |  |  |     |            |
|---------------------------|--|--|--|-----|------------|
| $t_{D\_ON}$               | Input to output propagation delay, Rising  | $DIAG\_EN=5V, I_{OUT}=0.5A, IN$ rising edge to 10% of $V_{OUT}$  |  | 30  | $\mu S$    |
| $t_{D\_OFF}$              | Input to output propagation delay, Falling | $DIAG\_EN=5V, I_{OUT}=0.5A, IN$ falling edge to 90% of $V_{OUT}$ |  | 35  | $\mu S$    |
| $\Delta V/\Delta t_{ON}$  | Turnon slew rate                           | $DIAG\_EN=5V, I_{OUT}=0.5A, V_{OUT}$ from 10% to 90%             |  | 0.4 | V/ $\mu S$ |
| $\Delta V/\Delta t_{OFF}$ | Turnoff slew rate                          | $DIAG\_EN=5V, I_{OUT}=0.5A, V_{OUT}$ from 90% to 10%             |  | 0.3 | V/ $\mu S$ |

## Current Sense timing

|                   |   |  |  |    |     |         |
|-------------------|---|--|--|----|-----|---------|
| $t_{CS\_ON(EN)}$  | CS settling time from $DIAG\_EN$ disabled | $I_{OUT}=0.5A, DIAG\_EN$ rising edge to $V_{CS}$ rising        |  | 2  | 15  | $\mu S$ |
| $t_{CS\_OFF(EN)}$ | CS settling time from $DIAG\_EN$ enabled  | $I_{OUT}=0.5A, DIAG\_EN$ falling edge to $V_{CS}$ falling      |  | 1  | 15  | $\mu S$ |
| $t_{CS\_ON(IN)}$  | CS settling time from $IN$ rising edge    | $DIAG\_EN=5V, I_{OUT}=0.5A, IN$ rising edge to $V_{CS}$ rising |  | 60 |     | $\mu S$ |
| $t_{CS\_OFF(IN)}$ | CS settling time from $IN$ falling edge   | $DIAG\_EN=5V, I_{OUT}=0.5A, IN$ rising edge to $V_{CS}$ rising |  | 5  |     | $\mu S$ |
| $t_{CS\_CL}$      | CS settling time from Current limit       | $DIAG\_EN=5V, IN=5V, OUT=0V, Current$ limit to $V_{CS\_H}$     |  |    | 150 | $\mu S$ |

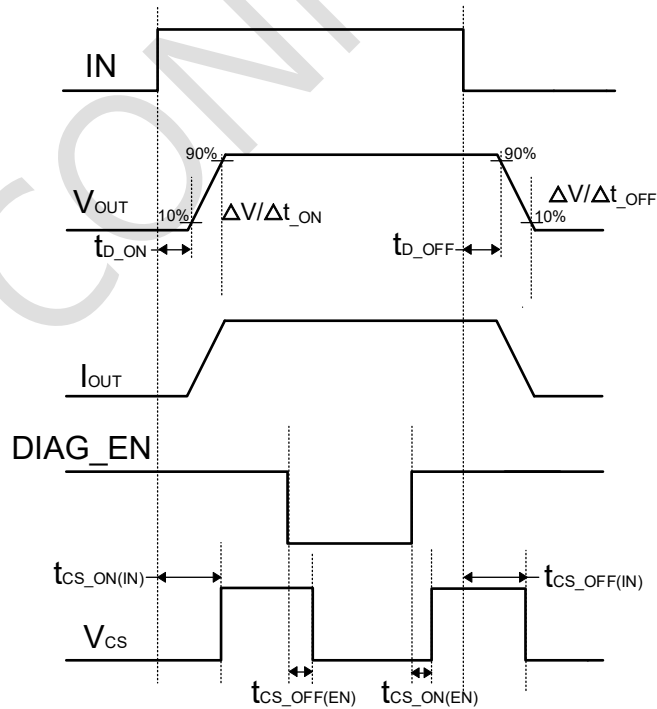

Figure 1. Output And CS Delay Sequential

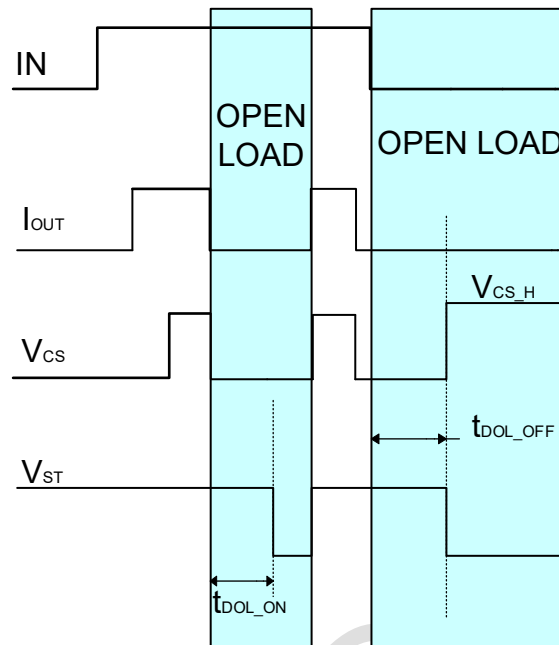

Figure 2. Open Load Delay

## TYPICAL CHARACTERISTICS

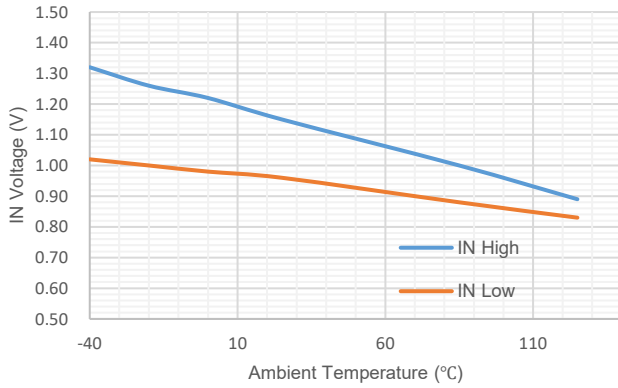

Figure 3. IN Threshold VS Temperature

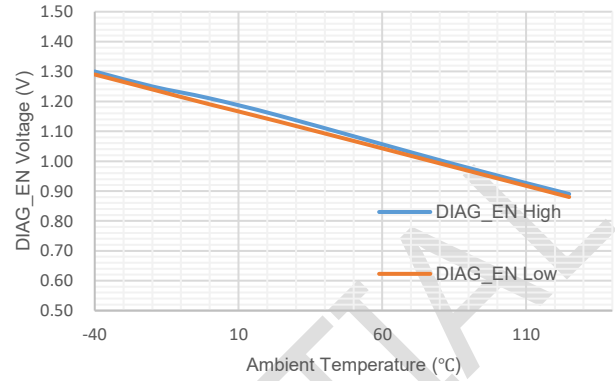

Figure 4. DIAG\_EN Threshold VS Temperature

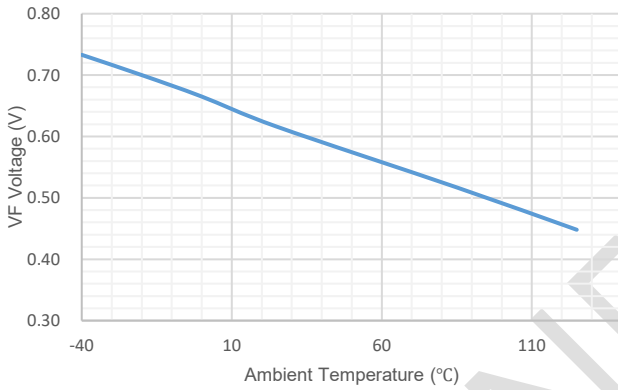

Figure 5. Body-Diode Forward Voltage VS Temperature

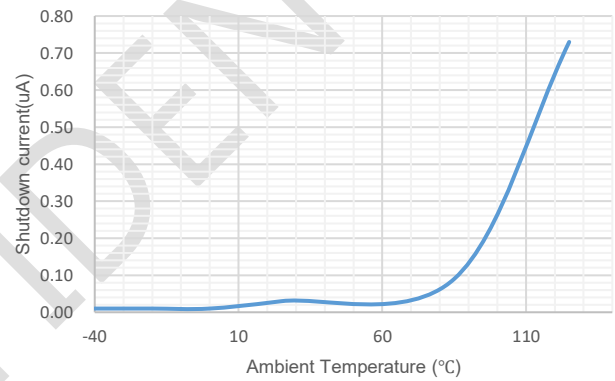

Figure 6. Ishutdown vs Input Voltage

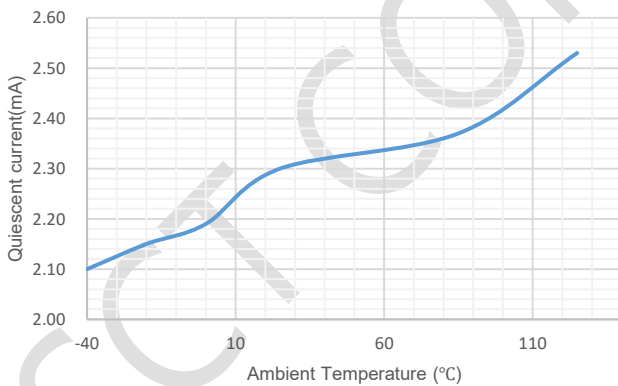

Figure 7. IQ vs Input Voltage

FUNCTIONAL BLOCK DIAGRAM

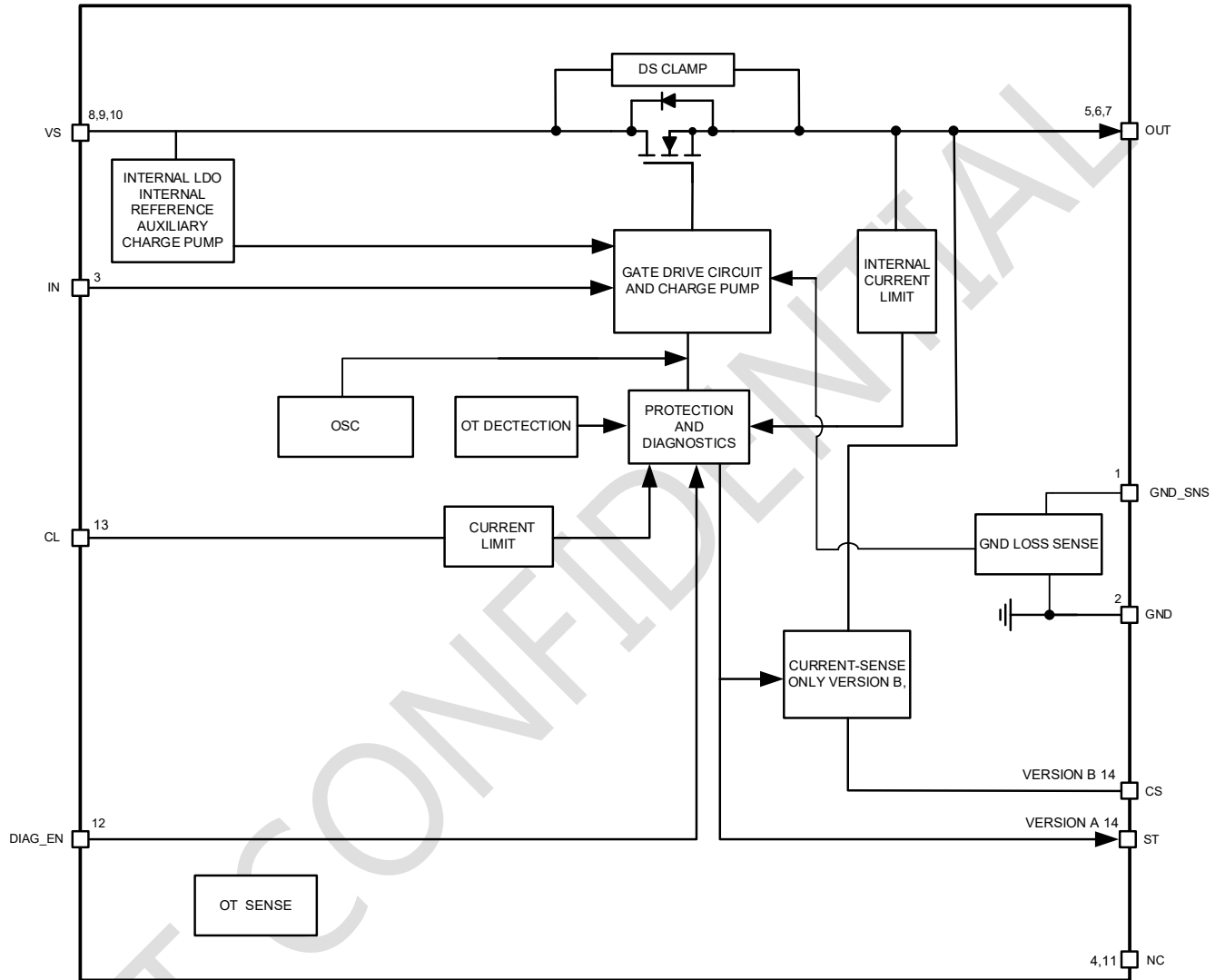

Figure 8. Functional Block Diagram

## OPERATION

### Overview

SCT41080 is a single-channel intelligent high-side switch that internally integrates a charge pump and power N-MOSFETs. SCT41080 offers external adjustable threshold overcurrent protection functionality, with a typical value of 12A for internal current limiting to enhance design flexibility and system reliability. This device features comprehensive diagnostic functions and high-precision current sensing functions to achieve smart control of the load. Among SCT41080's two versions, Version A includes an open-drain digital output diagnostic mode. Version B provides current sensing analog output.

In Version A, an open-drain digital output is utilized, and the diagnostic output pin ST needs to be pulled down to the ground externally by providing a pull-up voltage of 3.3V or 5V to match the MCU.

Version B has a current sensing analog output, enabling the system to accurately determine the operational status of channel. The integrated current mirror of the device provides a mirror current of  $1/K_{CS}$  load current, which flows through the CS resistor and becomes a voltage signal to achieve analog output of load current.

SCT41080 has a clamping function between the drain and source electrodes, which can effectively protect itself under inductive load conditions.

SCT41080 is an intelligent high-side switch suitable for applications where resistance, capacitance, and inductance loads can support most small load currents.

### Adjustable Current Limit

SCT41080 has an adjustable high-precision current limitation mechanism. When the load current reaches the designated threshold, it rapidly internally controls the N-MOSFET gate voltage to clamp the output current to the set value and report faults. When overcurrent occurs, there is high power dissipation in the device. If the device heats up and triggers thermal shutdown, the current limit will be reduced to  $I_{CL(TSD)}$  to reduce power dissipation on the device and further protect the device.

SCT41080 has two overcurrent protection thresholds, internal and external.

Internal current limitation, SCT41080 has a conventional value of 14A for internal integrated current limitation. When the CL pin is connected to the IC GND, the external current limitation becomes inactive, and protection is solely managed by the internal current limitation. This configuration is generally suitable for applications involving low VS voltage transient high current instances. At this point, there is a certain application risk when VS is under high voltage.

External adjustable current limit, SCT41080 can set the current limit threshold through an external  $R_{CL}$  resistor, which needs to be connected between CL and IC GND. Use Equation 1 to calculate the RCL resistance:

$$R_{CL} = \frac{V_{CL} \times K_{CL}}{I_{Limit}} \quad (1)$$

Where

- $V_{CL}$  is an internal reference value with a typical value of 1.233V
- $K_{CL}$  is a typical value of 4000 for the load current sampling ratio

**Accurate Current Sense**

Version B have high-precision current detection functions, which can accurately detect the real-time status of channel, making it convenient for the system to accurately diagnose the status of channel. Version B internally integrate a current mirror to mirror the load current. The ratio between the load current and the mirror current is  $K_{CS}$ : 1, and the mirror current flows through the CS pin and an external ground resistor  $R_{CS}$ , generating a voltage signal to achieve load current detection. Refer to Formula (2) for  $R_{CS}$  calculation:

$$R_{CS} = \frac{V_{CS} \times K_{CS}}{I_{OUTx\_MAX}} \tag{2}$$

Where

- $V_{CS}$  is the voltage value corresponding to the maximum load current, the values should refer in the EC table to  $V_{CS\_LIN}$  range
- $K_{CS}$  stands for the load current sampling mirror ratio, typically set to 1000.
- $I_{OUT\_MAX}$  represents the maximum load current value for the current channel.

When the system malfunctions, CS will pull up to  $V_{CS\_H}$  cooperates for fault detection. At this point, in order to make the fault detection judgment effective, there are limitations in equation (3) for the  $R_{CS}$ :

$$R_{CS} \geq \frac{V_{CS\_H(MIN)}}{I_{CS\_H(MIN)}} \tag{3}$$

Where

- $V_{CS\_H(MIN)}$  is the minimum value of  $V_{CS}$
- $I_{CS\_H(MIN)}$  is the minimum value of  $I_{CS}$

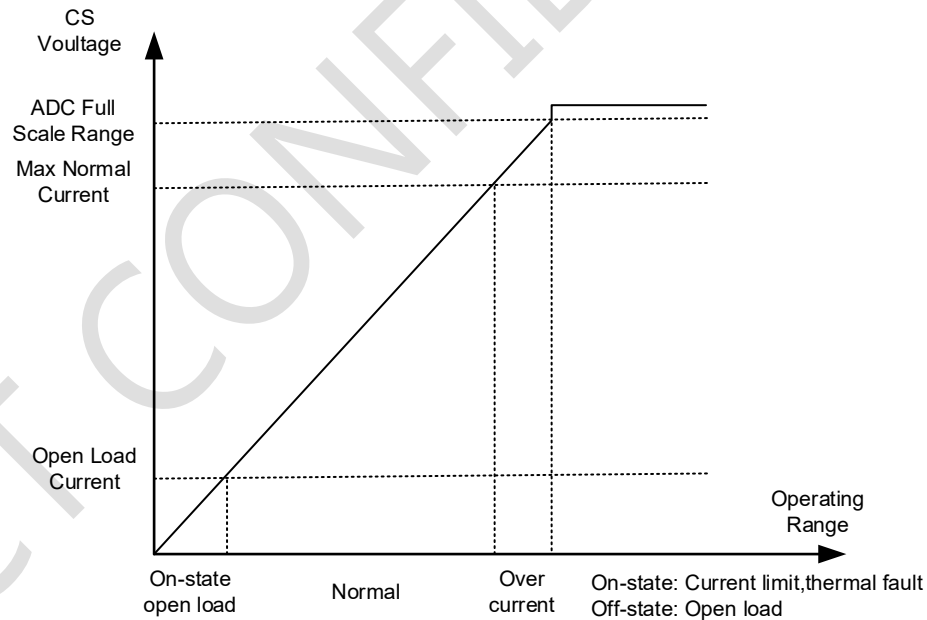

• Figure 9. Voltage Indication on the CS Pin

**Diagnostic Enable Function**

Through  $DIAG\_EN$  pin can set the device to enable or disable diagnostic functions. The diagnostic function is enabled when the  $DIAG\_EN$  is high, and disabled when the  $DIAG\_EN$  is low. When the diagnostic function is disabled, it will reduce the standby power consumption of the device.

# SCT41080

## Diagnostics Reporting

Version A, ST pins for fault reporting. Pulling down the internal ST device to GND, requires the external pull-up, with conventional values of 3.3V and 5V. When channel malfunctions, the corresponding ST pin will be pulled down to GND, so that the system can quickly detect the faulty channel.

Version B, Diagnose anomalies by checking if the CS pin voltage is  $V_{CS\_H}$ . The fault report is shown in Table 2:

Table 2. Fault Table

| Conditions                                    | INx | OUTx | Criterion                                | STx | CS               |
|---|-----|------|--|-----|------------------|
| Normal  | L   | L    | -  | H   | 0                |
|   | H   | H    | -  | H   | In linear region |
| Overload, short to ground                     | H   | L    | Current limit triggered                  | L   | $V_{CS\_H}$      |
| Open load, short to battery, reverse polarity | H   | H    | Version A: Output current $< I_{OL\_ON}$ | L   | Almost 0         |
|   | L   | H    | $V_{VS} - V_{OUT} < V_{OL\_OFF}$         | L   | $V_{CS\_H}$      |
| Thermal shutdown                              | H   | -    | TSD triggered                            | L   | $V_{CS\_H}$      |

## Open-Load Detection

There are two types of load open circuit detection:

- When IN is low, the channel is turned off, and due to the open circuit of the load, the OUT voltage cannot decrease rapidly. When the OUT voltage and power supply voltage still meet  $V_{VS} - V_{OUT} < V_{OL\_OFF}$  after  $t_{DOL\_OFF}$ , then an open load condition is determined, and ST, CS reports the fault. Due to potential leakage currents and external components, it is generally recommended to use a pull-up resistor between VS and OUT to offset leakage current, ensuring a more accurate open load report. The recommended value for pull-up resistance is 10k.
- When IN is high, the load current of version A is less than  $I_{OL\_ON}$ , ST diagnosis takes effect. The high-precision current detection function of version B. When the VCS voltage is detected to be too low, it can be considered that the load is open.

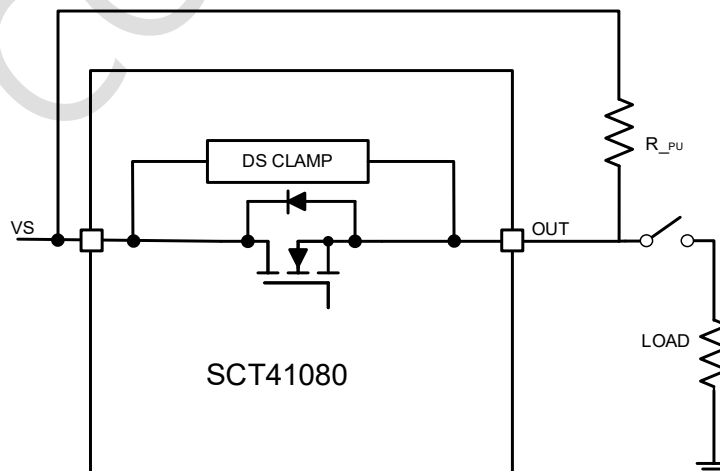

Figure 10. Open-Load Detection

## Loss-of-GND Protection

SCT41080 features Loss-of-GND protection. By connecting the GND\_SNS pin to external ground, in case of a loss of ground, the status is determined by the voltage difference between IC GND and the GND\_SNS pin connected to external ground. Regardless of whether IN is high or low, the channels will be deactivated for protection.

## Thermal Shutdown

Under extreme conditions like overcurrent, the device undergoes substantial power stress and heats up rapidly. SCT41080 incorporates two types of thermal protection: absolute thermal protection and relative thermal protection. These are designed to prevent rapid overheating of the device without protection. After triggering the thermal shutdown, when  $T_J < T_{SD-THYS}$ , the output will recover, but the current limit threshold will be reduced to 40% of the design value, reducing power stress and enhancing protection. When  $T_J < T_{SD-RST}$  or IN pin restart thermal fault signal will be cleared.

## Inductive-Load Switching-Off Clamp

When disconnecting the inductive load, the output will be pulled negative due to the influence of the induced electromotive force. At this time, the  $V_{S}$  voltage is still positive, and excessive output negative voltage may cause power MOSFET voltage breakdown. To protect the device, the SCT41080 internally integrates a voltage clamp function, namely  $V_{DS (clamp)}$ . When the output negative voltage is too large, the voltage between  $V_{S}$  and  $V_{OUT}$  will be clamped to  $V_{DS (clamp)}$  to protect the power MOSFET. When the energy of the inductive load is too large, it is recommended to use the method shown in Figure 13 for further protection.

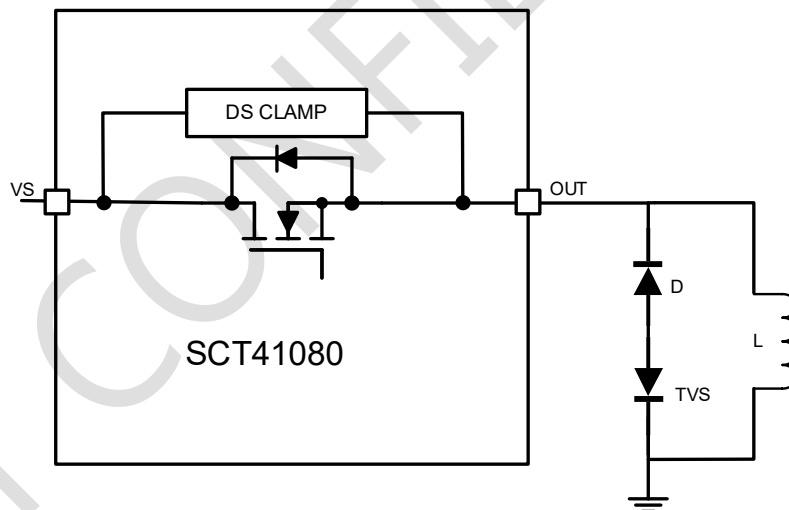

Figure 11. Inductive Load External Protection Circuit

## APPLICATION INFORMATION

### Protection for Loss of Power Supply

There is no risk for resistive or capacitive loads when the input power supply suddenly disconnects. However, for inductive loads, sudden changes in inductance current will generate induced electromotive force. It is recommended to add a GND network or external freewheeling diode to prevent excessive energy from damaging the chip. Join GND network GND\_SNS cannot be grounded to prevent ground failure error reporting.

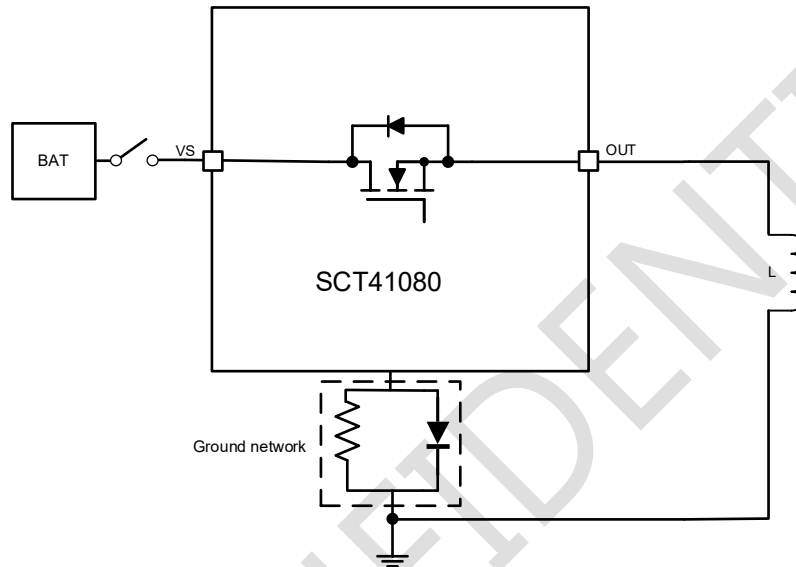

Figure 12. Ground Network Power Loss Protection

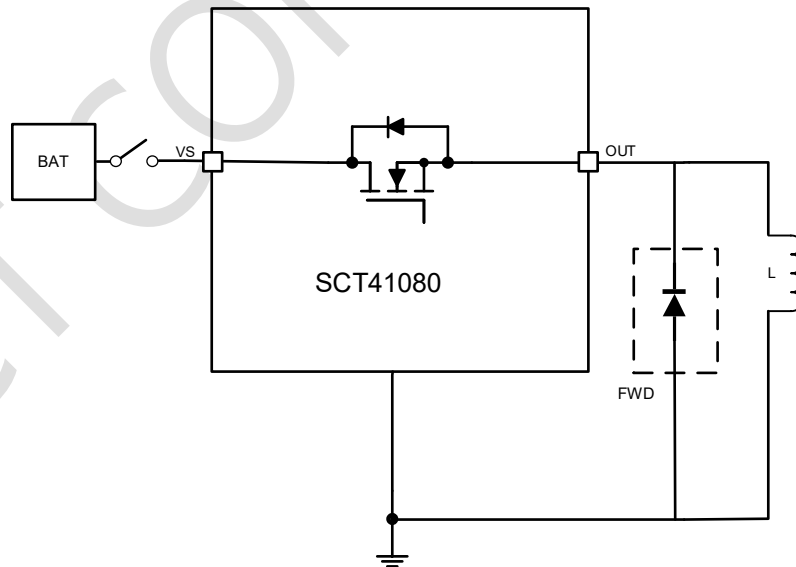

Figure 13. The Freewheeling Diode Power Loss Protection

**Reverse-Current Protection**

When there is an input short circuit, the reverse current flows to the input through the body diode, and when the input polarity is reversed, the reverse current flows to the input through GND and the body diode. Since the current-handling capacity of the GND pin is limited, for device protection, it's advisable to include a reverse protection diode at the input or incorporate it into the GND network. When a reverse protection diode is added to the input, both the load and the device are protected.

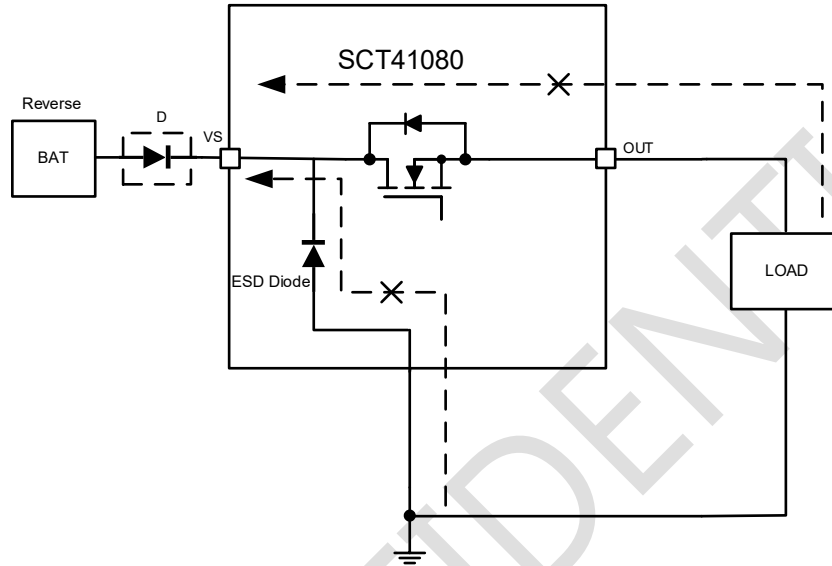

Figure 14. Anti Reverse Diode Power Reverse Protection

By adding to the GND network, the current flowing into IC GND will be limited, thus protecting the device.

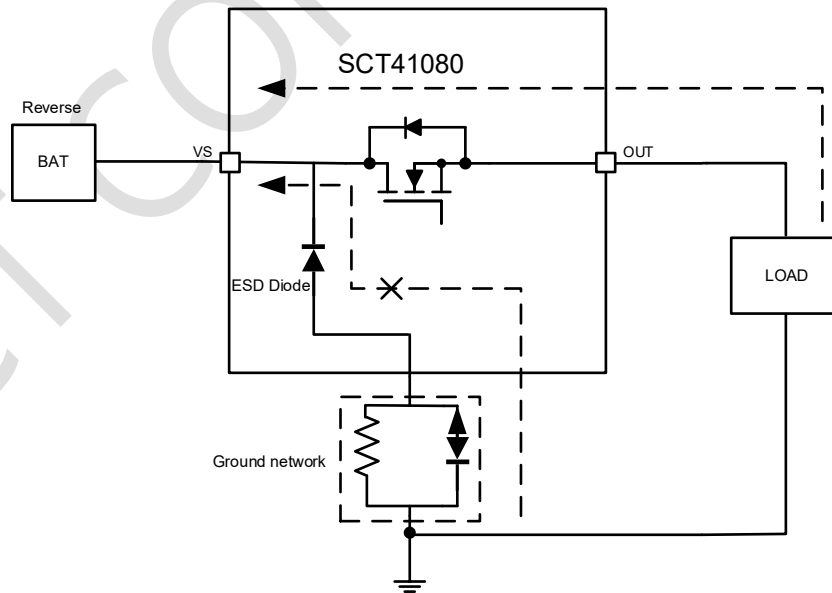

Figure 15. Ground Network Power Reverse Protection

# SCT41080

## MCU I/O Protection

In some extreme cases, such as ISO7637-2 testing or inductive load input disconnection, negative voltage pulses may appear in the IC GND relative to the system ground. To protect the MCU and the device, it is recommended to connect a series resistor between the MCU and the SCT41080 logic control pin.

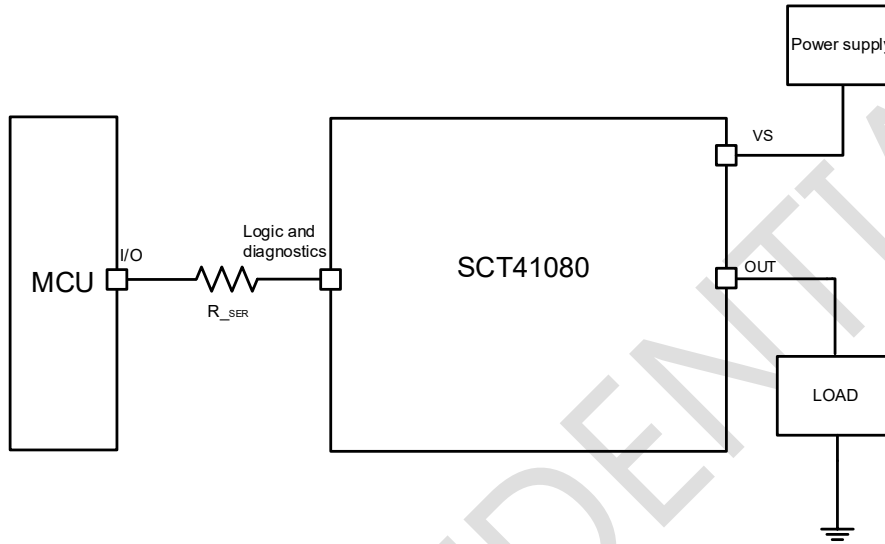

Figure 16. MCU I/O Protection

Typical Application

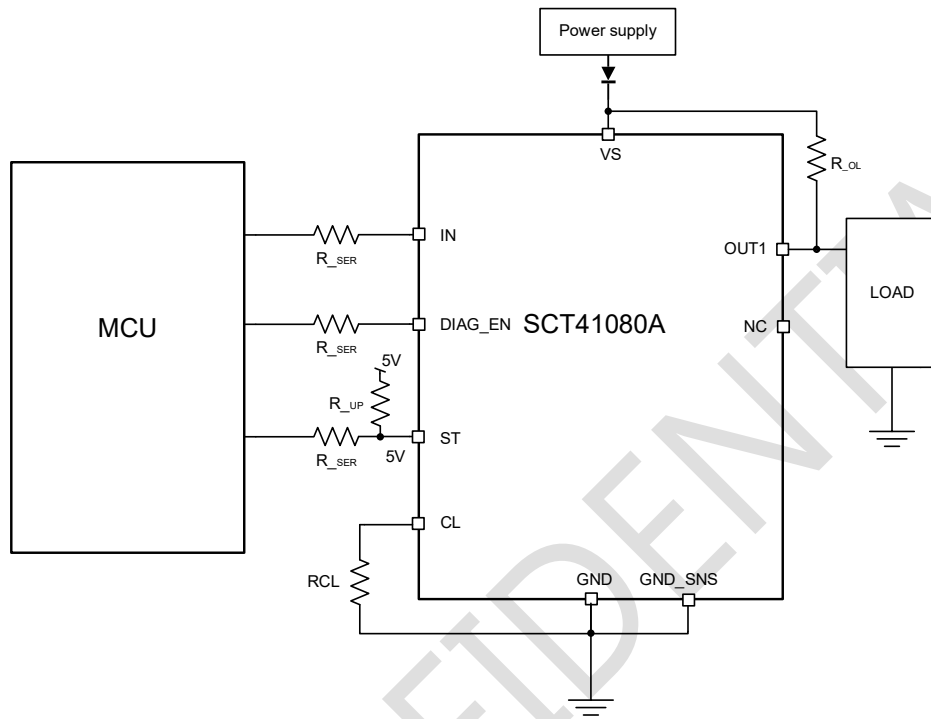

Figure 17. Version A Application Schematic

**Design Parameters**

| Design Parameters | Example Value          |
|-------------------|------------------------|
| Input Voltage     | 13.5V Normal 8V to 18V |
| Load Current      | Typical 4A             |
| Current Limit     | 5A                     |
| MCU Voltage       | 5V                     |

## Typical Application (continued)

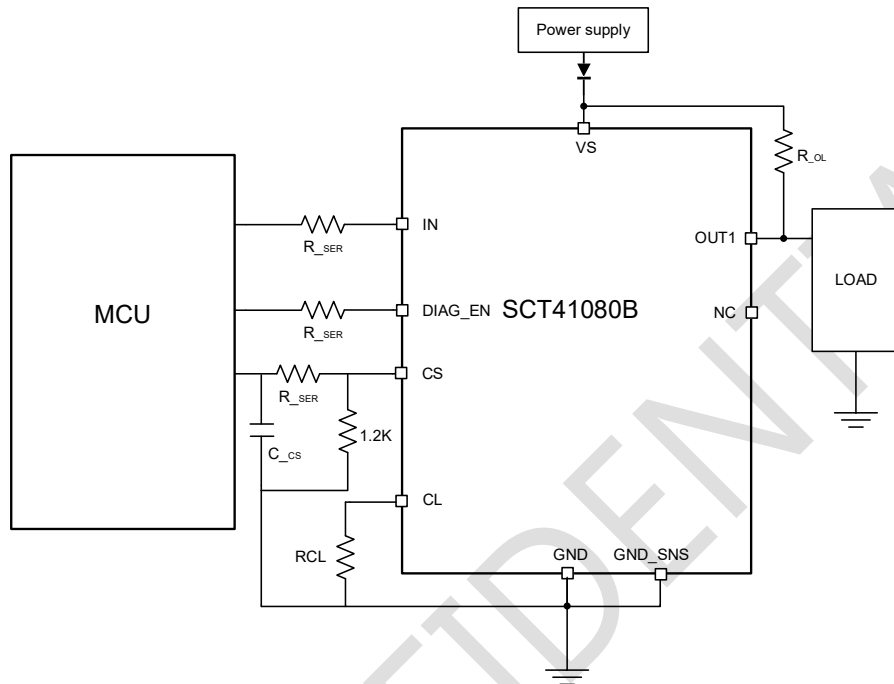

Figure 18. Version B Application Schematic

### Design Parameters

| Design Parameters   | Example Value          |
|---------------------|------------------------|
| Input Voltage       | 13.5V Normal 8V to 18V |
| Load Current        | Typical 4A             |
| Current Limit       | 5A                     |
| MCU Voltage         | 5V                     |
| Current Sense Range | 0-4A                   |

Application Waveforms

$V_{s}=13.5V$ , unless otherwise noted

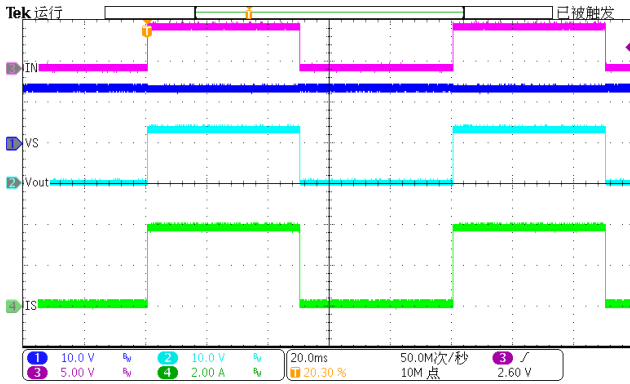

Figure 19. IN Toggle resistive load 4A

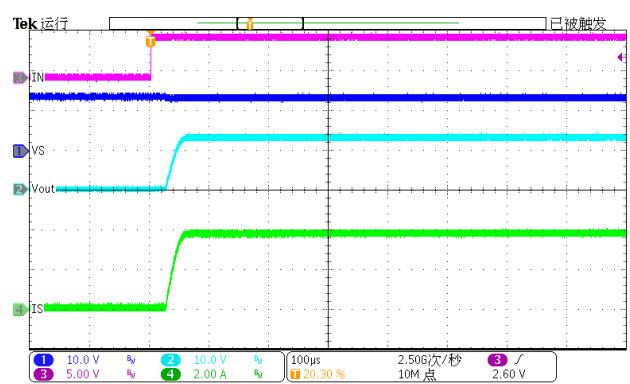

Figure 20. IN On resistive load 4A

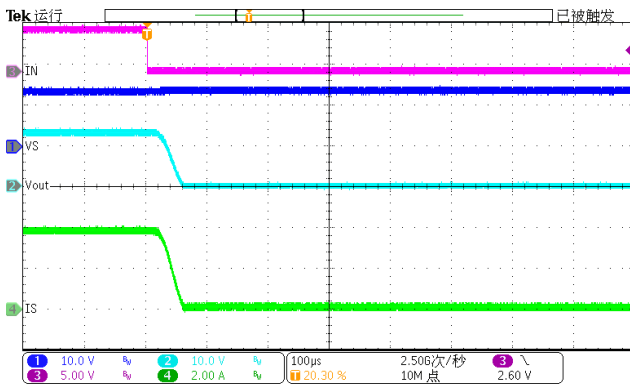

Figure 21. IN Off resistive load 4A

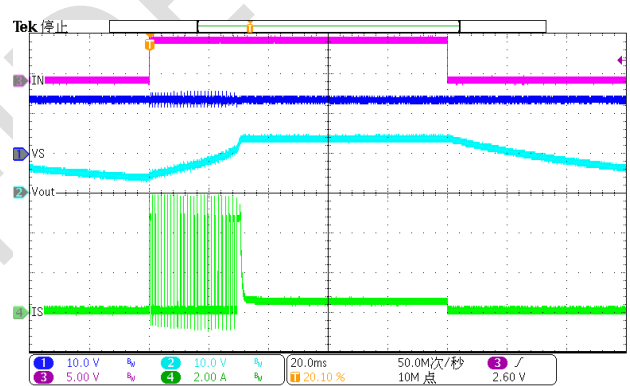

Figure 22. IN Toggle capacitive load C=2.2mF

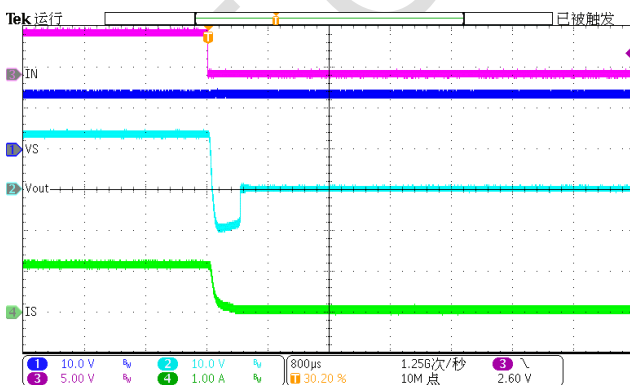

Figure 23. IN Off Inductive load L=8mH series resistor=13.5Ω

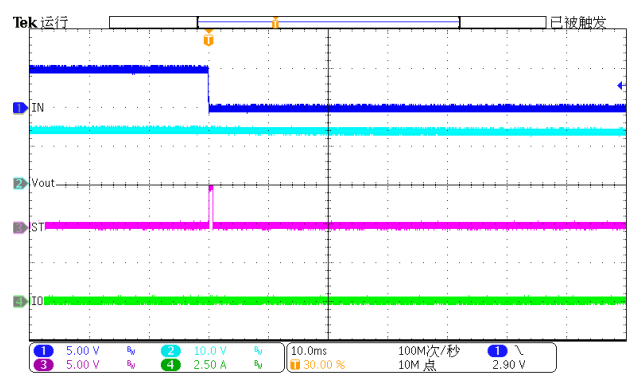

Figure 24. Open-load detection for version A

# SCT41080

## Application Waveforms(continued)

$V_{s}=13.5V$ , unless otherwise noted

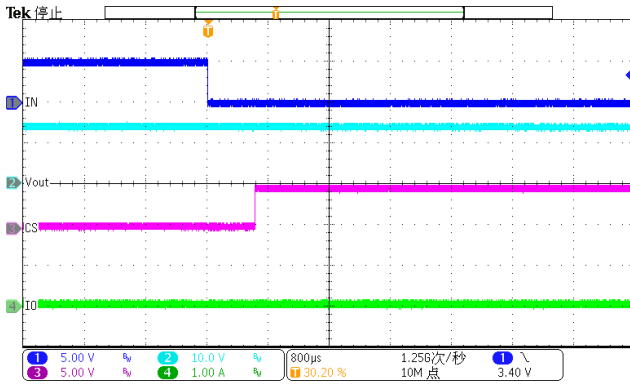

Figure 25. Open-load detection for version B

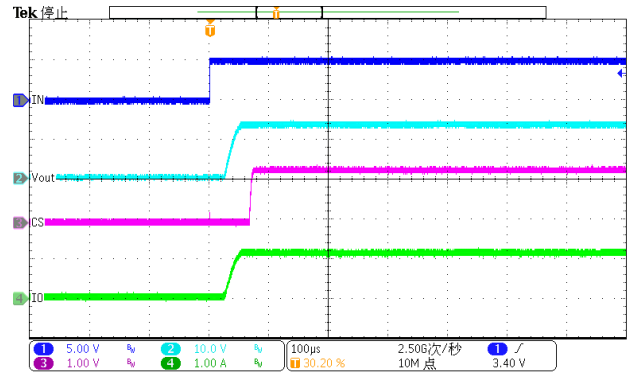

Figure 26. IN On current sense load=0.5A

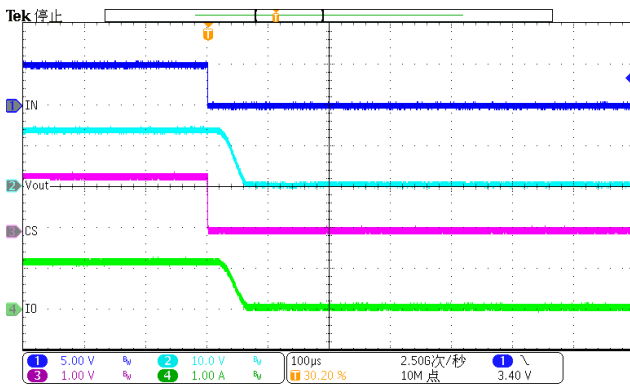

Figure 27. IN Off current sense load=0.5A

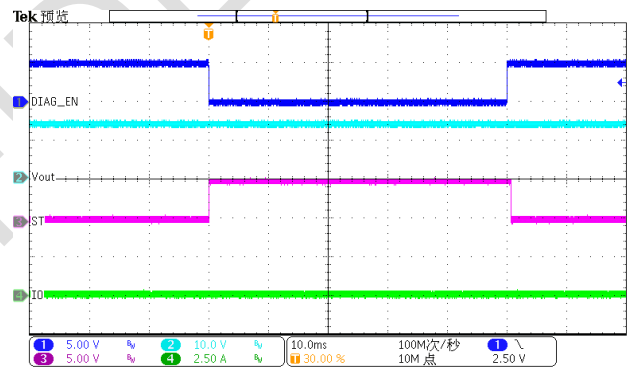

Figure 28. DIAG\_EN Toggle for version A

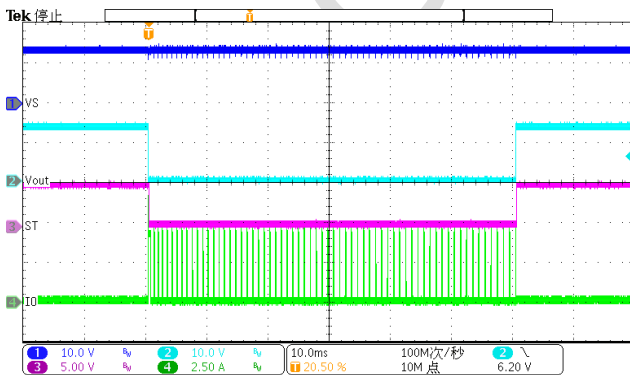

Figure 29. Overcurrent detection for version A

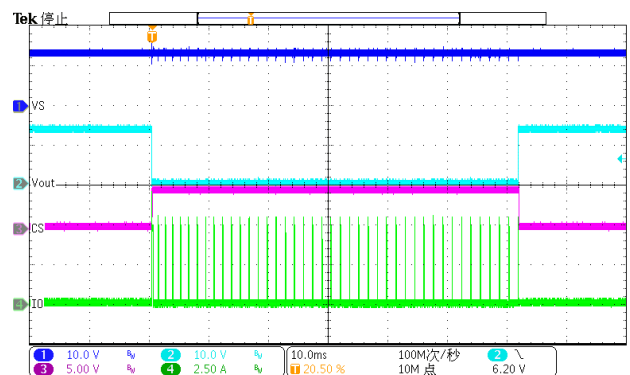

Figure 30. Overcurrent detection for version B

## Layout Guideline

The PCB layout is very important. Good PCB design can optimize heat transfer, which is absolutely essential for the long-term reliability of the device.

1. Maximize the copper coverage on the PCB to increase the thermal conductivity of the board. Maximum copper is extremely important when there are not any heat sinks attached to the PCB on the other side of the package.
2. More vias should be placed below the device Thermal PAD to further improve heat transfer.
3. R<sub>CL</sub> should be connected to IC GND.

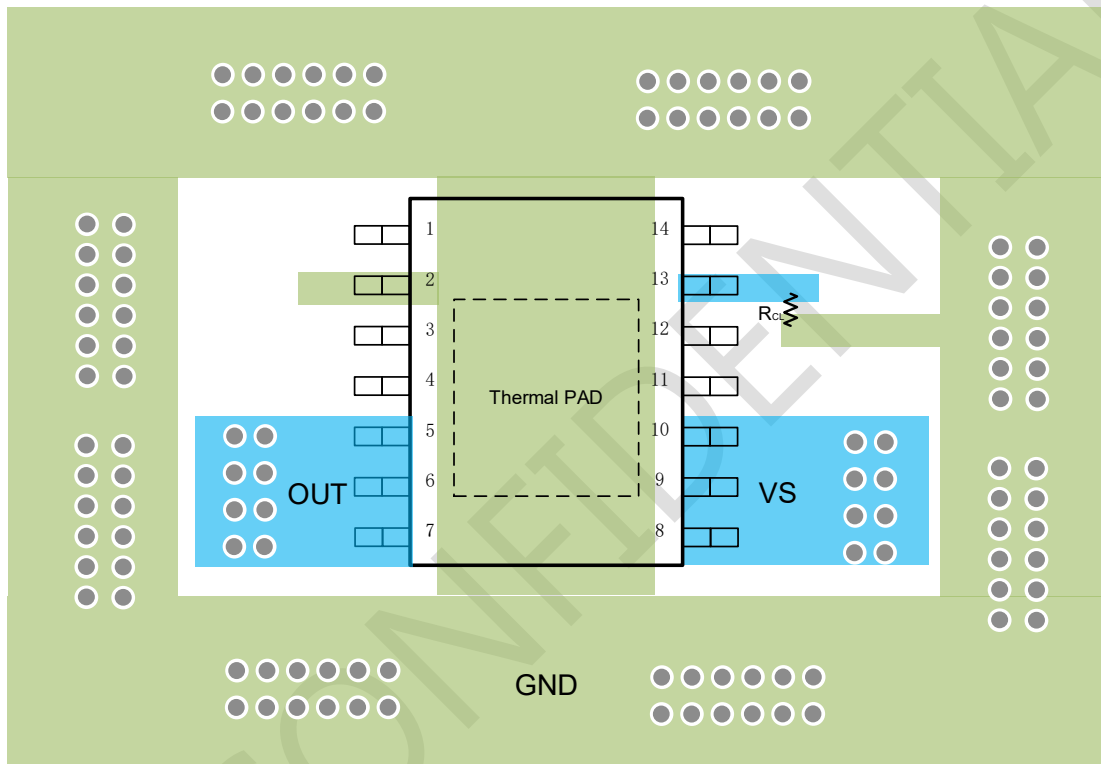

Figure 31. Without a GND Network PCB Layout

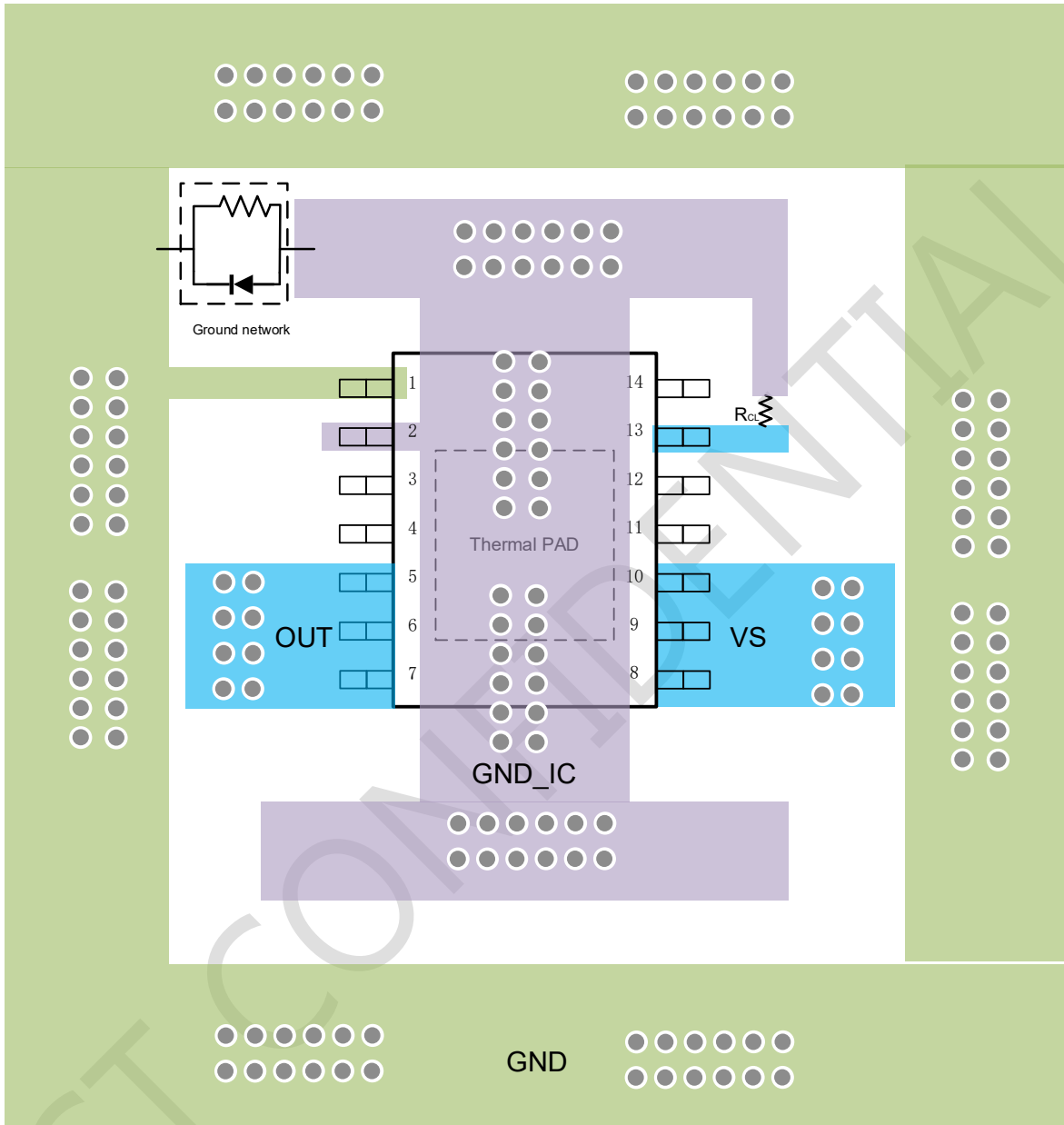
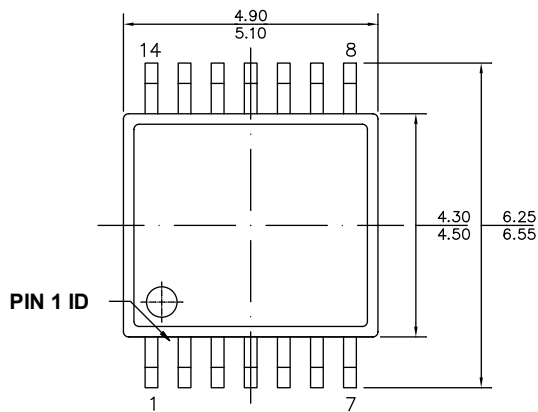
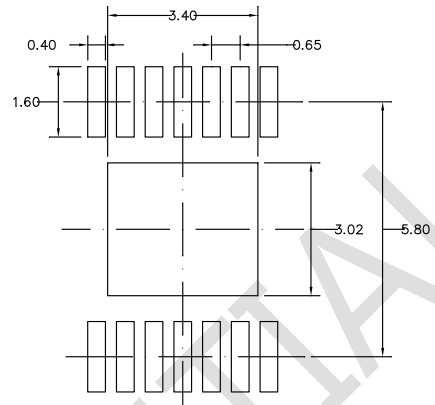

Figure 32. With a GND Network PCB Layout

PACKAGE INFORMATION



TOP VIEW



BOTTOM VIEW

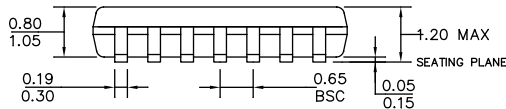

FRONT VIEW

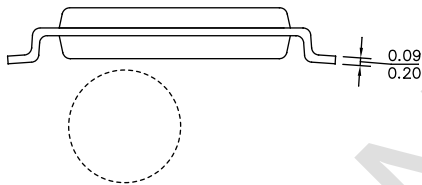

SIDE VIEW

SEE DETAIL "A"

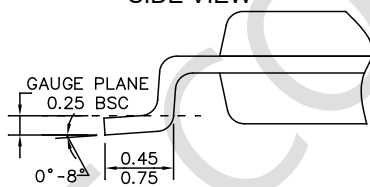

DETAIL "A"

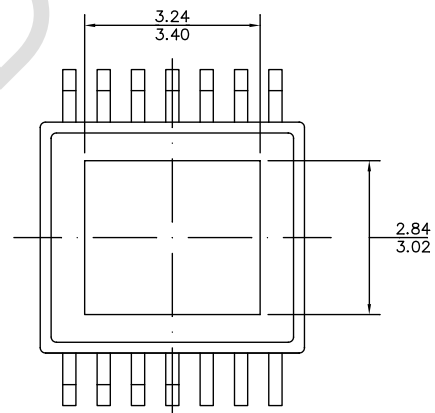

RECOMMENDED LAND PATTERN

NOTE:

1. ALL DIMENSIONS ARE IN MILLIMETERS..
2. PACKAGE LENGTH DOES NOT INCLUDE MOLD FLASH, PROTRUSION OR GATE BURR.
3. PACKAGE WITHDTH DOES NOT INCLUDE INTERLEAD FLASH OR PROTRUSION.
4. LEAD COPLANARITY (BOTTOM OF LEADS AFTER FORMING) SHALL BE 0.10 MILLIMETERS MAX.
5. DRAWING CONFORMS TO JEDEC MO-153, VARIATION ABT.
6. DRAWING IS NOT TO SCALE.

# SCT41080

## TAPE AND REEL INFORMATION

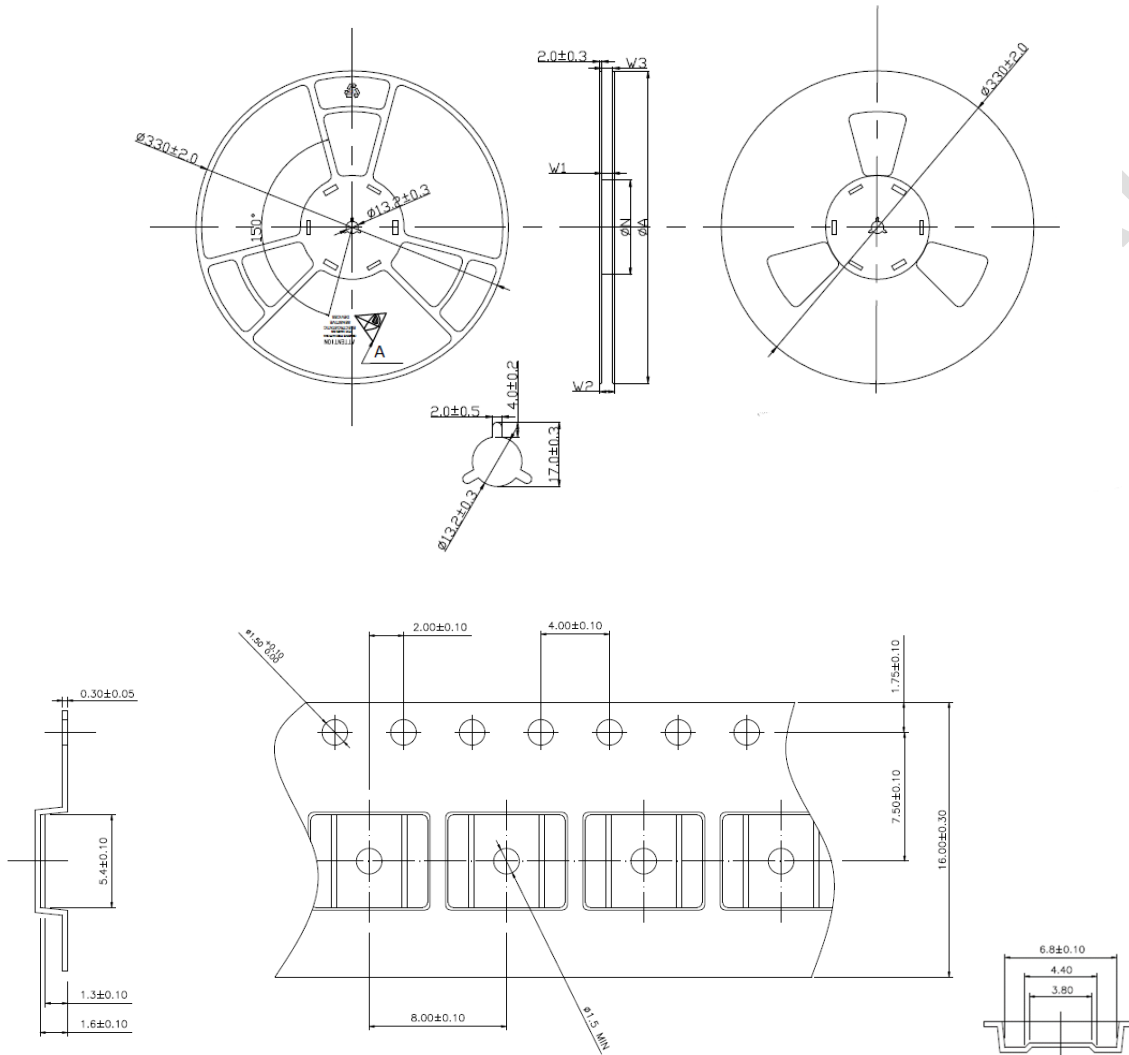

### NOTES:

1. 10 sprocket hole pitch cumulative tolerance  $\pm 0.2$ .
2. Camber not to exceed 1mm in 100mm
3.  $A_o$  and  $B_o$  measured on a plane 0.3mm above the bottom of the pocket
4.  $K_o$  measured from a plane on the inside bottom of the pocket to the top surface of the carrier
5. Pocket position relative to sprocket hole measured as true position of pocket not pocket hole.
6. Pocket center and pocket hole center must be same position.

### TAPE DIMENSIONS

| W<br>(mm) | $\Phi A$<br>(mm) | $\Phi N$<br>(mm) | W1<br>(mm)     | W2(Max)<br>(mm) | W3(Max)<br>(mm) |
|-----------|------------------|------------------|----------------|-----------------|-----------------|
| 16        | $330 \pm 2.0$    | $100 \pm 1.0$    | $16.4 \pm 0.5$ | 22.4            | 15.9/19.4       |